



Date	Group	No.	Release	Page
10.17	373	024	01	1(9)

Solenoid Bracket, Replacement
CHU, CXU, GU, TD

FSB 373-024, Solenoid Bracket, Replacement

(October 2017)

Some Mack trucks equipped with mDrive transmissions built between September 6, 2010 and August 14, 2017 may have PTO solenoid bracket or transmission harness connector failures due to excessive vibration. If a failure of the bracket and/or harness is found, replace the components as outlined in this procedure.

Required Parts

Part Description	Part Number	Quantity
Solenoid Bracket	23220187	1
Pigtail Harness	23117193	1
Harness Connector Backshell	3985621	2
Cable Tie	980881	N/A
Cable Tie	980464	N/A
Harness Tape	20469544	N/A

Decommissioning the Truck for Repair

You must read and understand the precautions and guidelines in Service Information, group 4, "General Safety Practices, Transmission" before performing this procedure. If you are not properly trained and certified in this procedure, ask your supervisor for training before you perform it.

You must read and understand the precautions and guidelines in Service Information, group 30, "General Safety Practices, Electrical" before performing this procedure. If you are not properly trained and certified in this procedure, ask your supervisor for training before you perform it.

NOTE: Information is subject to change without notice. Illustrations are used for reference only and can differ slightly from the actual vehicle being serviced. However, key components addressed in this information are represented as accurately as possible.

- 1 Park the vehicle on a flat and level surface.
- 2 Apply the parking brake.
- 3 Place the transmission in neutral or park.
- 4 Install the wheel chocks on the front wheels.

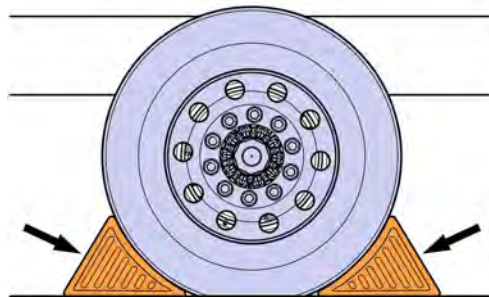

W7086748

- 5 Disconnect the cable from the battery's negative terminal.

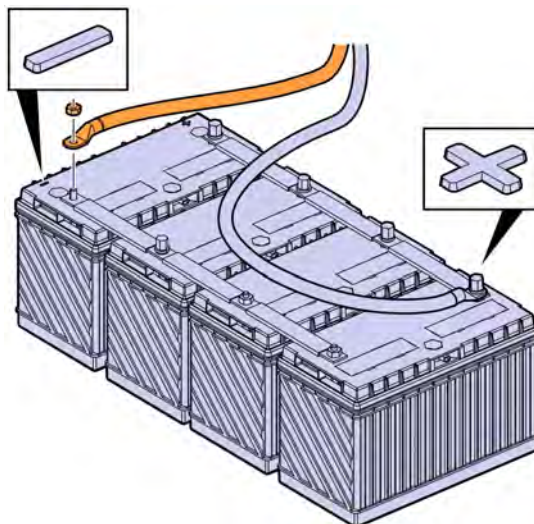

W3086747

Solenoid Bracket Removal.

You must read and understand the precautions and guidelines in Service Information, Function Group 20, "Engine Safety Practices" before performing this procedure. If you are not properly trained and certified in this procedure, ask your supervisor for training before you perform it.

- 1 Drain the air system.
- 2 Disconnect the electrical connectors and airlines.

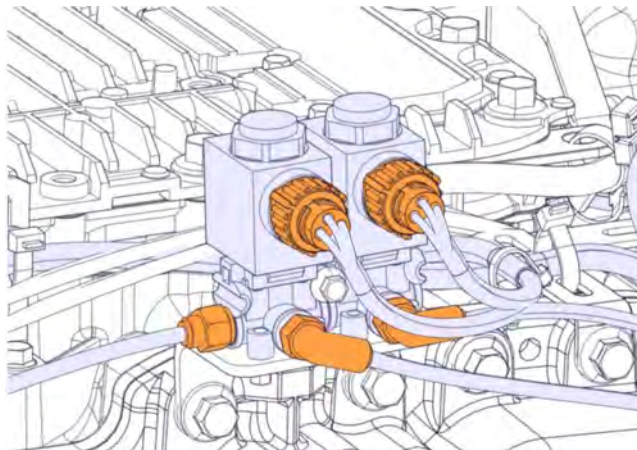

W4128709

- 3 Place tape over the exposed electrical connectors and caps over the ends of the airlines to protect against dirt or dust intrusion.
- 4 Remove the bolts used for securing the original bracket, and an additional bolt that will be used for securing the new bracket as shown.

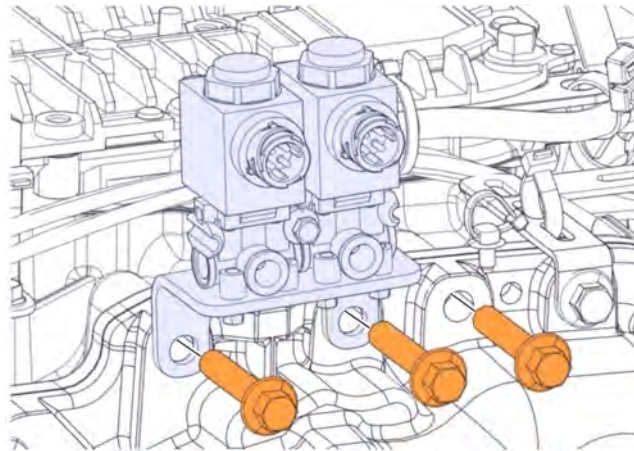

W4128710

- 5 Remove the bolts securing the solenoids to the bracket.

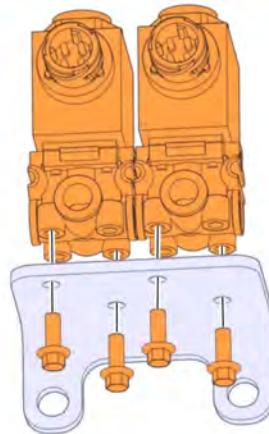

W4128711

Harness Connectors Replacement

Note: Replacing the end of the harness is only necessary if the harness is functionally or visually damaged.

- 1 Remove the cable ties securing the damaged piece of harness.
- 2 Cut the damaged harness leaving enough length on the original harness for the pigtail to reach the solenoids.
- 3 Remove the tape from the end of the harness approximately 2 inches.
- 4 Strip the insulation from each wire about 1/8 inch (3mm).

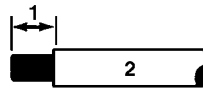

W3000569

- 5 Insert each wire into the corresponding wire butt splice on the pigtail and crimp until secure.

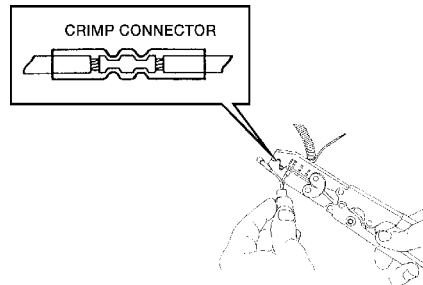

W3002876

- 6 Heat the butt splice until evidence of glue can be seen.

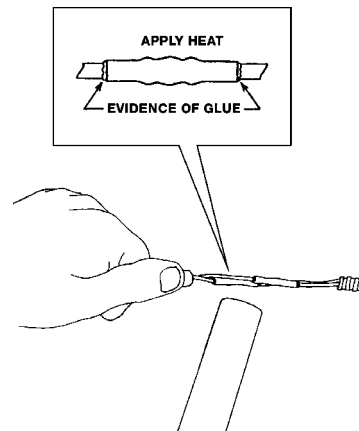

W3002877

- 7 Cover the butt splice and pigtail with harness tape.

Solenoid Bracket Installation

- 1 Install the solenoids to the new bracket.

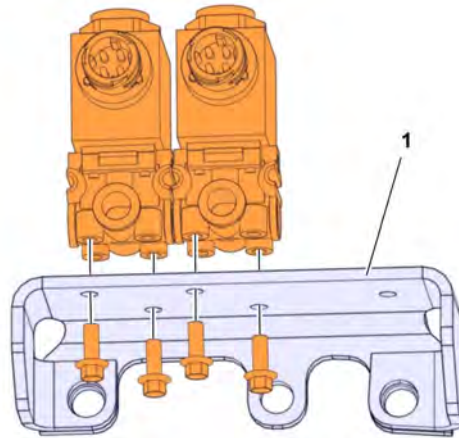

W4128712

Part Description	Part Number
Solenoid Bracket	23220187

- 2 Install the new bracket to the transmission.

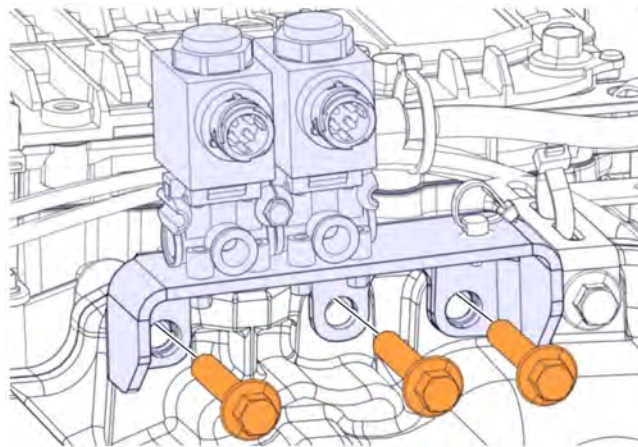

W4128713

- 3 Torque the bolts to 92±8 Nm (68±6 ft-lb).

- 4 If not already installed, install back covers to the harness connectors.

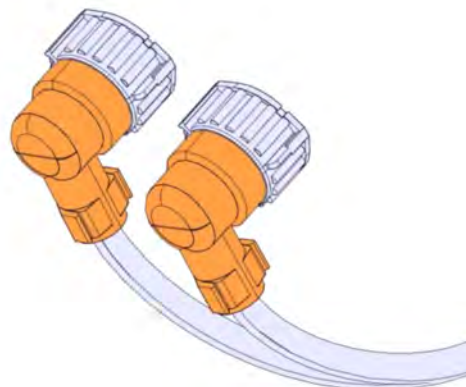

W3128769

- 5 Reconnect the airlines and the electrical harnesses to the solenoids.

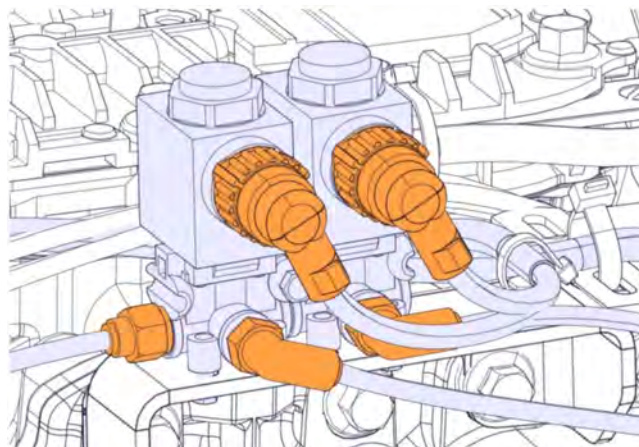

W4128714

6 Route and secure the harness with a cable ties as shown.

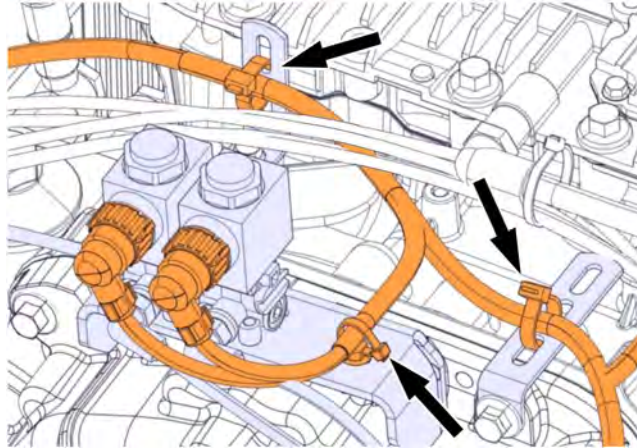

W3128763

Commissioning the Truck for Operation

1 Connect the battery cable to the negative (ground) terminal.

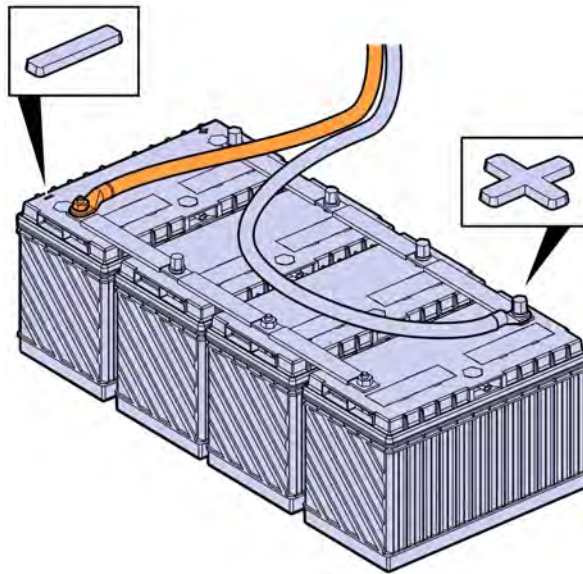

W3086758

2 Remove the wheel chocks.

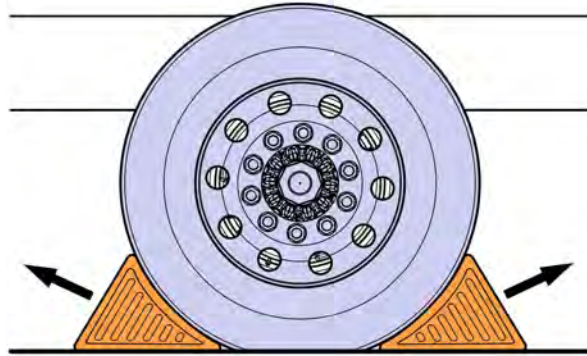

W7086759

Reimbursement

This repair is covered by an authorized Service Program. Reimbursement is obtained via the normal claim handling process.	UCHP Reimbursement
Claim Type (used only when uploading from the Dealer Bus. Sys.)	01
Labor Code Solenoid Bracket, Replacement	3731-03-09-05 1.0 hrs
Causal Part	20934428

MACK Trucks North America reserves the right to make any changes in design or to make additions to or upon its products without incurring any obligations to install the same on vehicles previously built.