



**NUMBER:** 23-039-17

**GROUP:** 23 - Body

**DATE:** September 2, 2017

*This bulletin is supplied as technical information only and is not an authorization for repair. No part of this publication may be reproduced, stored in a retrieval system, or transmitted, in any form or by any means, electronic, mechanical, photocopying, or otherwise, without written permission of FCA US LLC.*

**SUBJECT:**

Rear Door Fixed Glass Cover is Loose

**OVERVIEW:**

This bulletin involves rework to the rear door fixed glass cover trim.

**MODELS:**

2016 - 2017	(D2)	RAM 3500 Pickup
2016 - 2017	(DD)	RAM 3500 Cab Chassis
2016 - 2017	(DF)	RAM 3500 <10K LB Cab Chassis
2016 - 2017	(DJ)	RAM 2500 Pickup
2016 - 2017	(DP)	RAM 4500/5500 Cab Chassis
2016 - 2017	(DS)	RAM 1500 Pickup
2016 - 2017	(DX)	RAM Truck (Mexico)

**NOTE:** This bulletin applies to vehicles within the following markets/countries: NAFTA.

**NOTE:** This bulletin applies to vehicles built on or before September 01, 2017 (MDH 0901XX).

**SYMPTOM/CONDITION:**

The customer may notice the glass cover trim is loose or shows a gap on either of the rear door (Fig. 1) .



Fig. 1  
Gap Identified at Door

**DIAGNOSIS:**

If the customer describes the symptom/condition listed above, perform the Repair Procedure.

**SPECIAL TOOLS/EQUIPMENT REQUIRED:**

C-4755	Trim Stick
--------	------------

**REPAIR PROCEDURE:**

1. Remove the rear door glass fixed trim (Fig. 2) using trim stick C-4755 or equivalent, release the upper trim bezel.

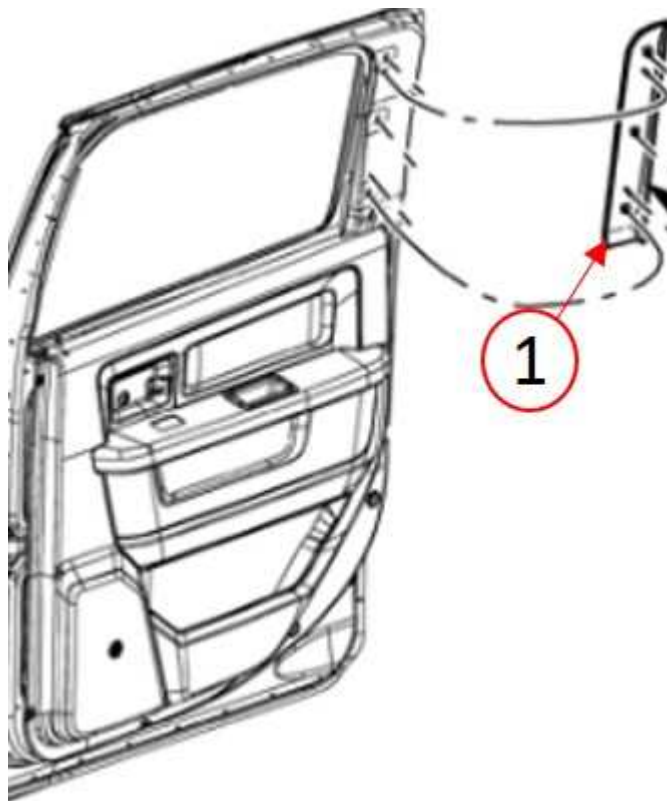

**Fig. 2**  
**Trim at Door**

1 - Door Glass Trim

---

2. After the trim piece is removed use a sharp knife or equivalent to remove the forward/short locator (Fig. 3) , remove the locator down to the substrate surface.

**NOTE: Do not remove or modify the rear/long locator (Fig. 3) .**

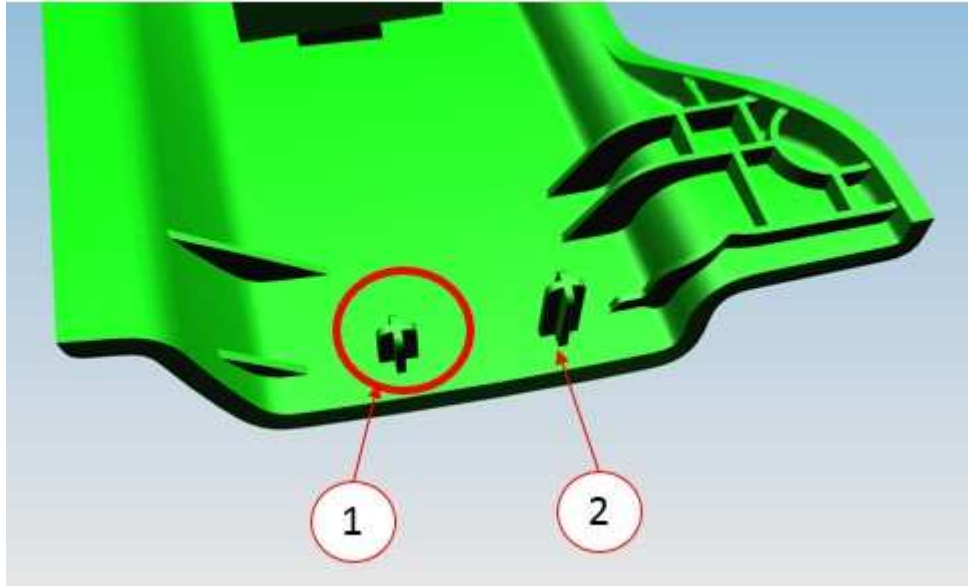

**Fig. 3**  
**Short Locator to be Removed**

- 1 - Locator to be Removed
- 2 - Do Not Remove this Locator

3. Install the rear door glass fixed trim (Fig. 2) .

**POLICY:**

Reimbursable within the provisions of the warranty.

**TIME ALLOWANCE:**

Labor Operation No:	Description	Skill Category	Amount
23-20-22-9H	Door, Glass Cover Trim - Rework/Modify Locator (1 - Semi-Skilled)	6 - Electrical and Body Systems	0.2 Hrs.

**FAILURE CODE:**

ZZ	Service Action
----	----------------