

NON COMPLIANCE RECALL

VOLVO Trucks North America
Greensboro, NC USA

VOLVO

| | Date | Number | Release | Page |
|-----------------------------------------------------------------------------------------------------------------------|---------|---------------|-----------|-------|
| This Field Service Bulletin replaces bulletin, "Engine Control Module (ECM) Software Updates" EC0017, dated (8.2017). | 08.2017 | EC0017 | 01 | 1(11) |

Engine Control Module (ECM) Software Updates VN, VHD, VAH

NON COMPLIANCE RECALL INFORMATION

(August 2017)

VOLVO Trucks has determined that certain 2014 and 2015 year model VN, VHD and VAH trucks equipped with a D13 model engine and may be equipped with an improperly functioning on-board emission-related diagnostic system.

The issue pertains to certain OBD (On-Board Diagnostic) monitors that may not illuminate the Malfunction Indicator Lamp (MIL) at the required threshold limits. This issue has no impact on fuel economy, drivability, performance, or safety of the engines.

To correct this issue, software updates are available for VOLVO Engine Control Modules (ECM) for D13 Engines.

The software updates will address potential issues with certain threshold monitors included in the OBD system. The affected OBD monitors, which include oil pressure plausibility, high fuel flow, Exhaust Gas Recirculation (EGR) slow to respond, boost system, Nitrogen Oxide (NOx) sensor plausibility, Idle Control System Monitoring, Non-Methane Hydrocarbon (NMHC) Converting Catalyst Monitoring, Compressor Discharge Temperature Sensor-Plausibility Monitoring, and DPF performance may fail to illuminate the malfunction indicator lamp MIL at the thresholds required by the regulation.

Follow the software update procedure outlined in this document.

The vehicle models and model years affected are as follows:

VEHICLES AFFECTED and QUANTITY

Quantity:

There are 18833 total vehicles affected in this recall (15,978 U.S., 2,852 Canada, 2 Mexico, and 1 Export).

Vehicle Models and Years:

Certain 2014 and 2015 VN, VHD, and VAH year model vehicles equipped with a D13 model engine.

MATERIAL NEEDED

Order the following Material:

| Required Parts | | |
|----------------|-------------------------------------------------------------------------------------------------|-----|
| Part Number | Description | Qty |
| 85152363 | Emissions Recall Completion Sticker (All) | 1 |
| N/A | Recall Completion certificate US-CAN (EN) NOTE: See last page of recall for this form | 1 |

REQUIRED TOOLS

- Premium Tech Tool (PTT) version 2.05.86 or higher
- Vocom Diagnostic Connector 88890304 or 88890253
- Communication Interface 88890300

NOTE

Using other interfaces may affect programming speed.

NOTE

Check Premium Tech Tool version by clicking on Help tab and then click on "About Tech Tool".

SOFTWARE UPDATE PROCEDURE

You must read and understand the precautions and guidelines in Service Information, Function Group 20, "General Safety Practices, Engines" before performing this procedure. If you are not properly trained and certified in this procedure, ask your supervisor for training before you perform it.

Note: Information is subject to change without notice. Illustrations are used for reference only, and may differ slightly from the actual vehicle being serviced. However, key components addressed in this information are represented as accurately as possible.



Do not attempt to repair or service this vehicle without having sufficient training, the correct service literature and the proper tools. Failure to follow this could make the vehicle unsafe and lead to serious personal injury or death.

1. Park the vehicle on a level surface.
2. Apply the parking brake.
3. Place the transmission in neutral or park.
4. Install the wheel chocks.

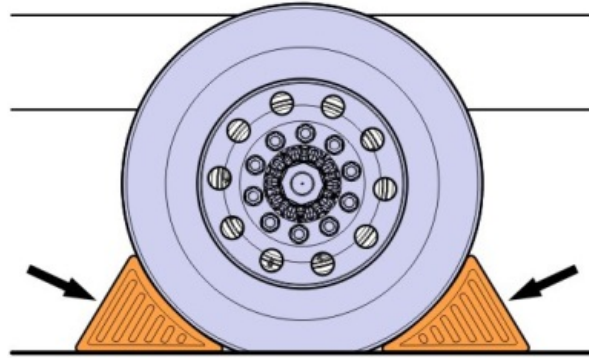

5. Verify service program eligibility by checking service program status in VDA.
6. Connect Premium Tech Tool (PTT) to the vehicle diagnostics connector using the 16 pin OBD cable 88890304 and Communication Interface 88890300. Connect the PC to a functional LAN or modem connection and a 120 Volt AC source.
7. Turn the ignition switch “**ON**”.
8. Log in to PTT and Identify Vehicle is displayed.
9. Once the vehicle has been identified, enter the Work Order Number information. Then, click **Start Work**.

A screenshot of a software dialog box titled "Work Order Number". The dialog has a white background and a grey border. At the top, it says "Enter a work order number or select a recently used work order number in the list." Below this, there are two options: "Enter work order number:" followed by a text input field, and "Select a recently used work order:" followed by a table. The table has three columns: "Work Order No", "User ID", and "Date". Below the table is a text area labeled "Enter Notes:". At the bottom right of the dialog, there are two buttons: "Start Work" and "Cancel". A large white arrow with a black outline points to the "Start Work" button.

- From the Main Menu select Program and then Program Electronic Control Unit 1700-08-03-39. Then, click **Start**.

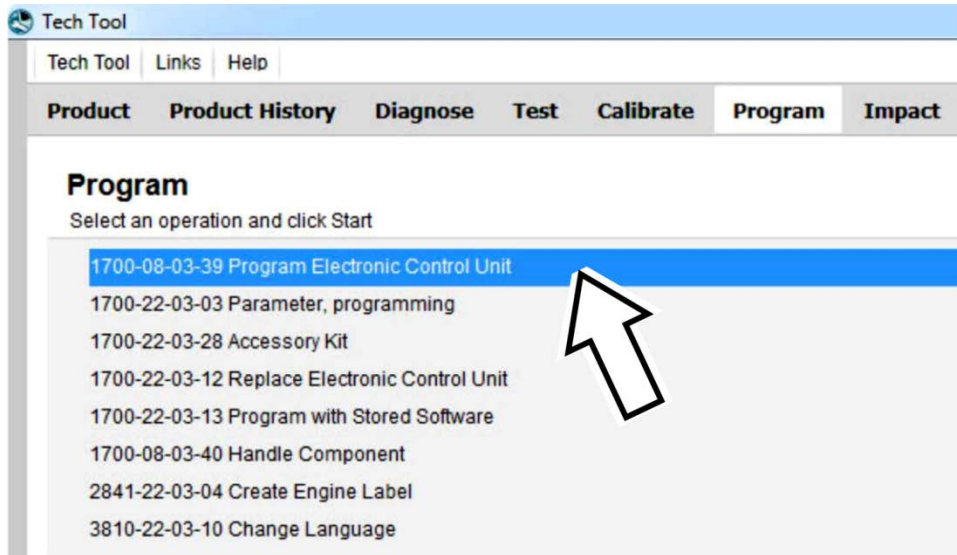

- Select **EMS**.

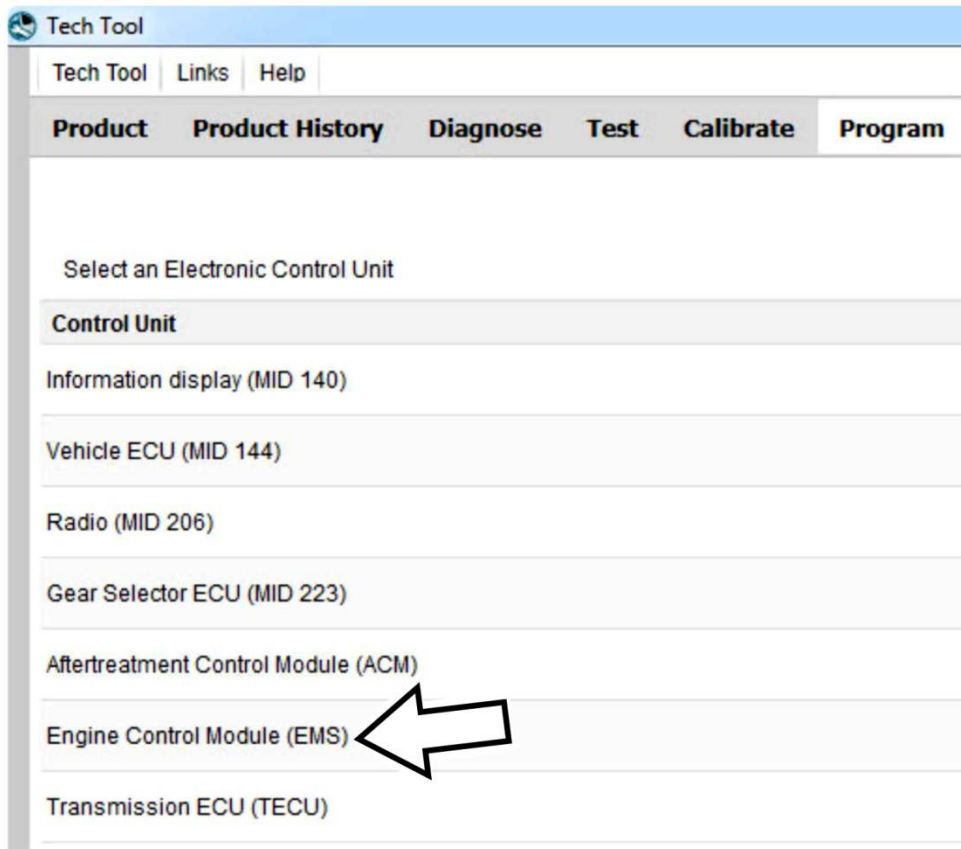











12. Select Program to update the EMS with the latest software.

Programming options

Update control unit with latest software

Reload control unit with existing software

13. Certain conditions must be met to continue with programming: battery voltage above 10v, parking brake applied, and ignition key in ON position with engine not running. When all conditions have been met, click Continue to proceed with programming.

| | | | |
|---|---------------------------------------------------------------------------------------------------------------------------------------------------------------------------------|-------------------------------------------------------------------------------------------|-------------------------------------------------------------------------------------|
| 1 |  > 10 V | 12.7 V |  |
| 2 |   |  |  |
| 3 |   = 0 rpm |  0 rpm |  |

1700-08-03-39 Program control unit - Update software

Automatically checked conditions

- 1 Battery voltage above 10 V
- 2 Parking brake applied
- 3 Ignition key in **ON** position. Engine not running

14. Select "I accept" to agree to the terms and press continue to proceed.

NOTE

In the United States and Canada, the programing is NOT chargeable.
An invoice will not be generated.

1700-08-03-39 Program control unit - Update software

The following control units will be programmed

Engine Control Module (EMS)

Chargeable programming

The software you are about to program is chargeable. If programming is performed using the software, an invoice will be generated.

Programming will be charged once even if multiple retries are needed.

The software has commercial part number

85136079 : Engine Control Module

The number can be used for price lookup in your local system and will be specified on the invoice.

I accept



Select I accept to agree to the terms Press Continue to proceed

15. If the software is already updated, this screen opens. Select **(Yes)** to reload existing software.

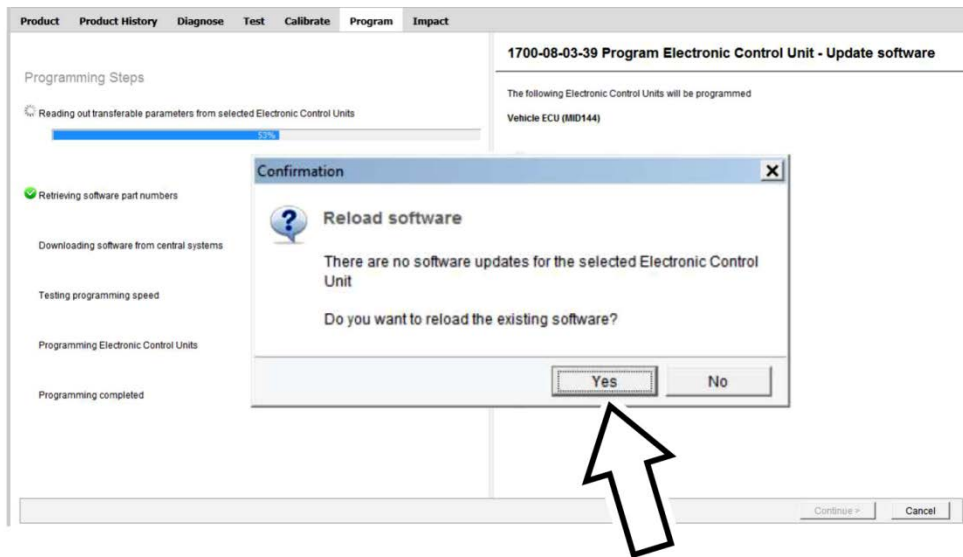

16. When the programming is complete, clear any diagnostic trouble codes (DTC) and Finish Work.

17. Remove the wheel chocks.

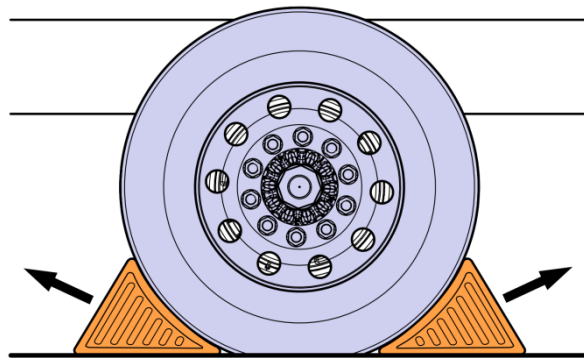

REIMBURSEMENT

| | |
|-----------------------------------------------------------------------------------------------------------------------------------------------------|--------------------------|
| This repair is covered by an authorized Non Compliance Recall campaign. Reimbursement is obtained through the normal claim handling process. | |
| Claim Type (used only when uploading from the Dealer Business System) | R |
| Recall Status | |
| Vehicle repaired per instructions | |
| Labor Code | |
| Primary Labor Code, Engine Control Module (ECM), Software Updates | 2841-22-09-12 0.3 hrs |
| Time to take charge of vehicle and determine campaign status | 1700-16-01-01 0.3 hrs |
| Parts Disposition | N/A |
| Causal Part | 3092091 |
| SCC Code | C6587 |

Note: Take Charge Time is not included in the labor code for this operation. Take charge may be eligible, but can only be used once per vehicle repair visit. If the vehicle is having other warranty repairs performed, take-charge should be charged to the warranty repair, otherwise take-charge can be charged to this Non Compliance Recall campaign.

Note: Dealers are to perform Non Compliance Recall Campaigns on all subject vehicles at no charge to the vehicle owner regardless of mileage, age of vehicle or ownership (original purchaser or subsequent purchasers). Whenever vehicles are subject to a Non Compliance recall are brought to your dealership for service, or taken into your dealership vehicle inventory, it is strongly recommended that every effort be made to perform the recall correction before the vehicle is sold or released to the owner.

