

<b>Subject:</b> <b>SQUEAK NOISE FROM FRONT BRAKES AND/OR GROOVE MARKS ON FRONT DISC PLATE</b>	<b>Bulletin No.:</b> 04-002/17
	<b>Last Issued:</b> 07/21/2017

## BULLETIN NOTES

This bulletin supersedes the previously issued bulletin(s) listed below. The changes are noted below in Red.

Previously Issued TSBs:	Date(s) Issued
04-002/17	02/17/17
04-004/15	10/07/15
04-005/14	11/11/14, 10/28/14, 10/29/14, and 10/31/14

## APPLICABLE MODEL(S)/VINS

2014-2016Mazda3 with VINs lower than JM1BM\*\*\*\*\*355941 (produced before June 23, 2016)  
 2017 Mazda3with VINs lower than JM1BN\*\*\*\*\*144508 (produced before March 8, 2017)  
 2016-2017CX-3with VINs lower than JM1DK\*\*\*\*\*171927 (produced before March 8, 2017)

## DESCRIPTION

Some vehicles may exhibit a squeak noise when applying the brakes and/or groove marks (A) on the front disc plates. This is caused by abrasive metal from the front disc plate sticking to the brake pad, which damages the disc plate over time. To correct the problem, a modified brake pad is being used.

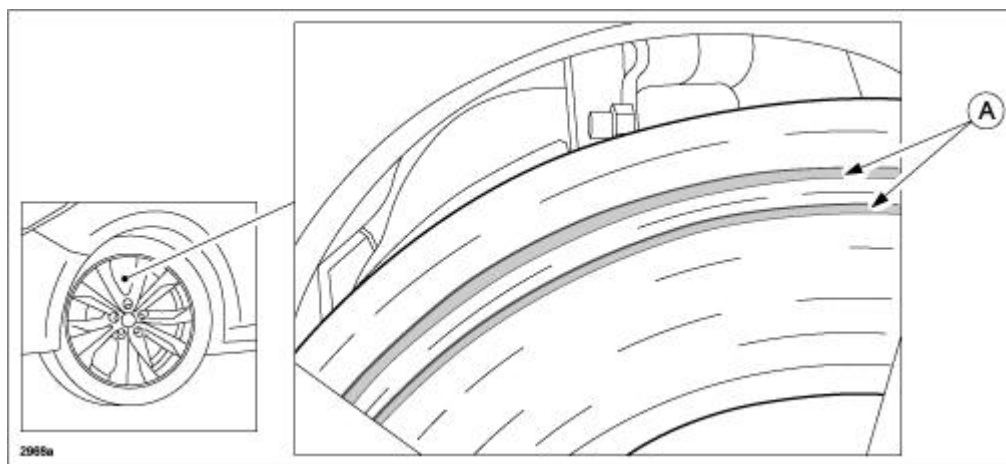

Customers having this concern should have their vehicle repaired using the following repair procedure.

**CONSUMER NOTICE:** The information and instructions in this bulletin are intended for use by skilled technicians. Mazda technicians utilize the proper tools/equipment and take training to correctly and safely maintain Mazda vehicles. These instructions should not be performed by "do-it-yourselfers." Customers should not assume this bulletin applies to their vehicle or that their vehicle will develop the described concern. To determine if the information applies, customers should contact their nearest authorized Mazda dealership. Mazda North American Operations reserves the right to alter the specifications and contents of this bulletin without obligation or advance notice. All rights reserved. No part of this bulletin may be reproduced in any form or by any means, electronic or mechanical---including photocopying and recording and the use of any kind of information storage and retrieval system ---without permission in writing.

## REPAIR PROCEDURE

1. Verify customer concern. 2. Inspect the front brake pads and disc plates for damage and replace according to the inspection results as follows:

### Front Brake Pads

Visually inspect the front brake pads surface for pieces of metal.

- If metal pieces (silver or white in color) are found in a line (A) or cluster form (B) on the surface, replace the front brake pads with a modified service set.

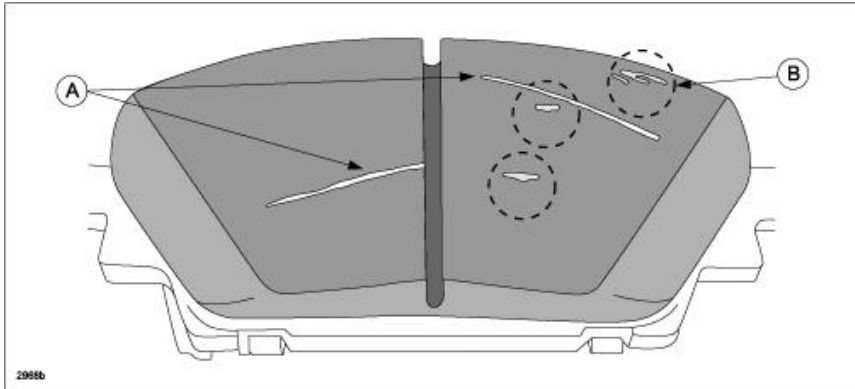

### Front Disc Plates

Visually inspect the surface of the disc plate(s) for damage.

- If groove damage is found on a disc plate (A) and brake pad (B), replace the front brake pads with a modified service set and **ONLY** the damaged disc plate(s).

**NOTE:** Metal may have dropped off the brake pad, and groove damage will be found on the brake pad in the same position as damage on the disc plate.

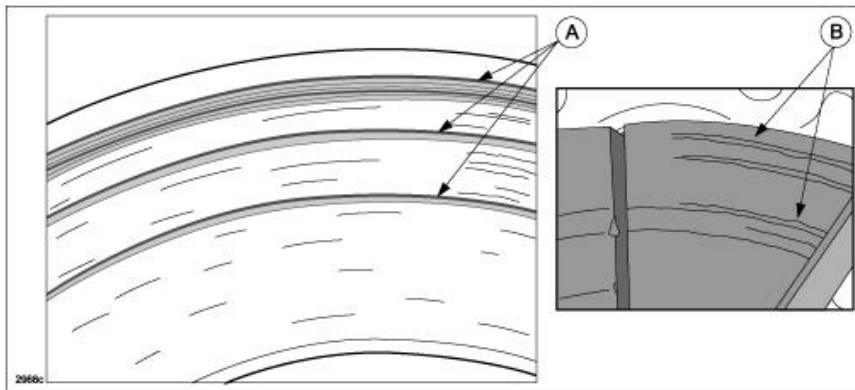

3. Verify repair.

**PARTS INFORMATION**

Mazda3

Part Number	Description	Qty.	Notes
B6YS-33-28ZA	Front Brake Pad Set	1	All
BPY1-33-251	Front Disc Plate	1 / One side	2.0L
BHY3-33-251	Front Disc Plate	1 / One side	2.5L

CX-3

Part Number	Description	Qty.	Notes
B6YS-33-28ZA	Front Brake Pad Set	1	All
BPY1-33-251	Front Disc Plate	1 / One side	2WD
BHY3-33-251	Front Disc Plate	1 / One side	4WD

**WARRANTY INFORMATION****NOTE:**

- This warranty information applies only to verified customer complaints on vehicles eligible for warranty repair.
- This repair will be covered under Mazda's New Vehicle Warranty.
- Additional diagnostic time cannot be claimed for this repair.

Replacement of Front Brake Pads Only

Warranty Type	A
Symptom Code	82
Damage Code	9D
Part Number Main Cause	BPY1-33-251 (2.0L) BHY3-33-251 (2.5L)
Quantity	0
Operation Number / Labor Hours:	XXX9LARX / 0.4 Hrs

**NOTE:** Claim the brake pads as a related part number on all claims.

**CONSUMER NOTICE:** The information and instructions in this bulletin are intended for use by skilled technicians. Mazda technicians utilize the proper tools/equipment and take training to correctly and safely maintain Mazda vehicles. These instructions should not be performed by "do-it-yourselfers." Customers should not assume this bulletin applies to their vehicle or that their vehicle will develop the described concern. To determine if the information applies, customers should contact their nearest authorized Mazda dealership. Mazda North American Operations reserves the right to alter the specifications and contents of this bulletin without obligation or advance notice. All rights reserved. No part of this bulletin may be reproduced in any form or by any means, electronic or mechanical---including photocopying and recording and the use of any kind of information storage and retrieval system ---without permission in writing.

## Replacement of Front Brake Pads and Disc Plate(s)

	Replacement of Front Brake Pads and one (1) Disc Plate	Replacement of Front Brake Pads and two (2) Disc Plate
Warranty Type	A	A
Symptom Code	82	82
Damage Code	9D	9D
Part Number Main Cause	BPY1-33-251 (2.0L) BHY3-33-251 (2.5L)	BPY1-33-251 (2.0L) BHY3-33-251 (2.5L)
Quantity	1	2
Operation Number / Labor Hours:	XXK9LBRX / 0.5 Hrs	XXK9LCRX / 0.6 Hrs

**NOTE:** Claim the brake pads as a related part number on all claims.

**CONSUMER NOTICE:** The information and instructions in this bulletin are intended for use by skilled technicians. Mazda technicians utilize the proper tools/equipment and take training to correctly and safely maintain Mazda vehicles. These instructions should not be performed by "do-it-yourselfers." Customers should not assume this bulletin applies to their vehicle or that their vehicle will develop the described concern. To determine if the information applies, customers should contact their nearest authorized Mazda dealership. Mazda North American Operations reserves the right to alter the specifications and contents of this bulletin without obligation or advance notice. All rights reserved. No part of this bulletin may be reproduced in any form or by any means, electronic or mechanical---including photocopying and recording and the use of any kind of information storage and retrieval system ---without permission in writing.