

**Subject:**

**09-026/17 - THIRD-ROW SEAT HEADREST DOES NOT LOCK IN UPRIGHT POSITION**

**Bulletin No.:** 09-026/17

**Last Issued:** 06/20/2017

## DESCRIPTION

### APPLICABLE MODEL(S)/VINS

2016-2017 CX-9 vehicles with VINs lower than JM3TC\*\*\*\*\*100980 (produced before April 1, 2017)

Some customers may complain that the third-row seat headrest(s) are loose (A) and do not lock in the upright position (B) or the headrest are locked in the forward-bent position (C).



These concerns are caused by improper operation while the seatback is folded down (A) and an excessive force is applied to the headrest (B) while it's in the upright locked position. When excessive force is improperly applied, this causes damage to the headrest lock mechanism (C).

**CONSUMER NOTICE:** The information and instructions in this bulletin are intended for use by skilled technicians. Mazda technicians utilize the proper tools/equipment and take training to correctly and safely maintain Mazda vehicles. These instructions should not be performed by "do-it-yourselfers." Customers should not assume this bulletin applies to their vehicle or that their vehicle will develop the described concern. To determine if the information applies, customers should contact their nearest authorized Mazda dealership. Mazda North American Operations reserves the right to alter the specifications and contents of this bulletin without obligation or advance notice. All rights reserved. No part of this bulletin may be reproduced in any form or by any means, electronic or mechanical---including photocopying and recording and the use of any kind of information storage and retrieval system ---without permission in writing.

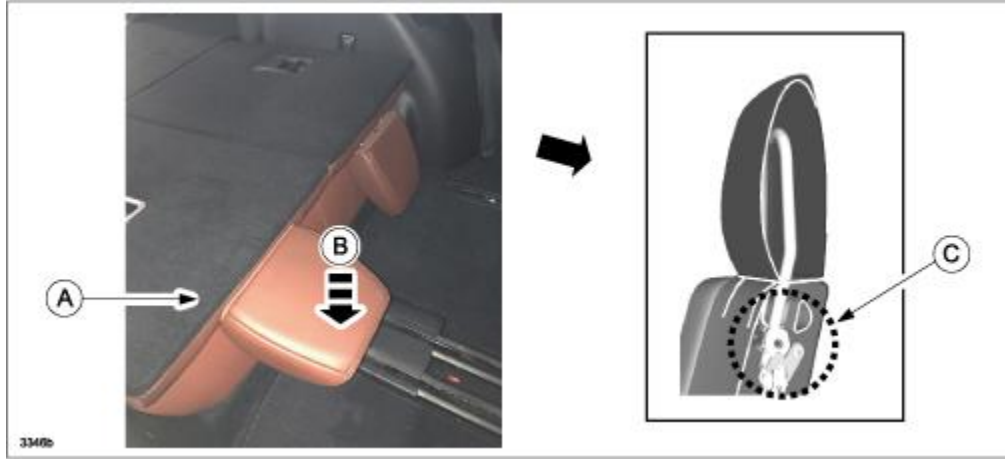

**EXAMPLE:**

Correct head restraint fold down position.	Wrong head restraint fold down position.	Damage may occur if excessive force is applied to the back of the head restraint when in the wrong position.

Although this concern is caused by improper operation, the strength of the headrest lock mechanism has been increased to address the customer satisfaction issue. The related parts have also been modified. Customers having this concern should be instructed that they can prevent this issue from occurring by not applying excessive force to the headrests.

For additional information on the proper usage of the "Third-Row Seat" and "Head Restraints", refer all customers to the "Essential Safety Equipment" pages found in Chapter 2 of their Owner's Manual.

**CONSUMER NOTICE:** The information and instructions in this bulletin are intended for use by skilled technicians. Mazda technicians utilize the proper tools/equipment and take training to correctly and safely maintain Mazda vehicles. These instructions should not be performed by "do-it-yourselfers." Customers should not assume this bulletin applies to their vehicle or that their vehicle will develop the described concern. To determine if the information applies, customers should contact their nearest authorized Mazda dealership. Mazda North American Operations reserves the right to alter the specifications and contents of this bulletin without obligation or advance notice. All rights reserved. No part of this bulletin may be reproduced in any form or by any means, electronic or mechanical---including photocopying and recording and the use of any kind of information storage and retrieval system ---without permission in writing.

Essential Safety Equipment  
**Seats****Third-Row Seat****▼ Split folding the Third-Row Seats**

To create a flat luggage compartment space, fold the seatbacks forward.

**NOTE**

When folding the seatbacks forward, fold them in two steps.

**Folding the seatbacks (With strap)**

1. Slide the second-row seat all the way forward.
2. Pull the strap to fold down the head restraint.

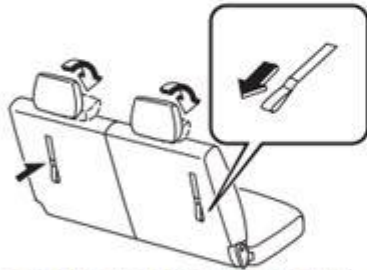

3. Pull the strap further to fold the third-row seat forward.

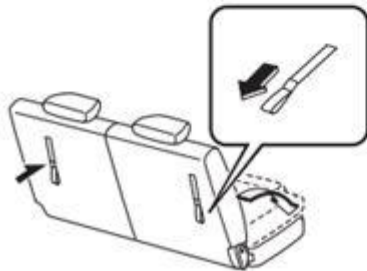
**Folding the seatbacks (With lever)**

1. Slide the second-row seat all the way forward.
2. Lower the lever to fold down the head restraint.

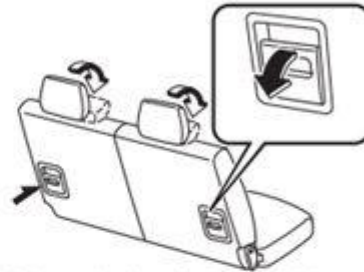

3. Lower the lever further to fold the third-row seat forward.

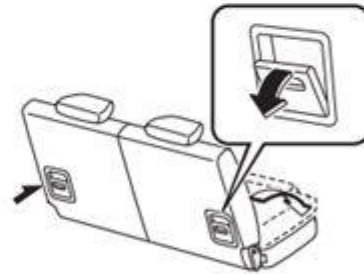

2-15

Customers should also have their vehicle repaired using the following repair procedure.

**REPAIR PROCEDURE**

1. Verify the customer concern.
2. Replace the affected side third-row seatback component with a modified part according to the instructions

**CONSUMER NOTICE:** The information and instructions in this bulletin are intended for use by skilled technicians. Mazda technicians utilize the proper tools/equipment and take training to correctly and safely maintain Mazda vehicles. These instructions should not be performed by "do-it-yourselfers." Customers should not assume this bulletin applies to their vehicle or that their vehicle will develop the described concern. To determine if the information applies, customers should contact their nearest authorized Mazda dealership. Mazda North American Operations reserves the right to alter the specifications and contents of this bulletin without obligation or advance notice. All rights reserved. No part of this bulletin may be reproduced in any form or by any means, electronic or mechanical---including photocopying and recording and the use of any kind of information storage and retrieval system ---without permission in writing.

on MGSS online (THIRD-ROW SEAT BACK COMPONENT REMOVAL/INSTALLATION). Bolts - (A)

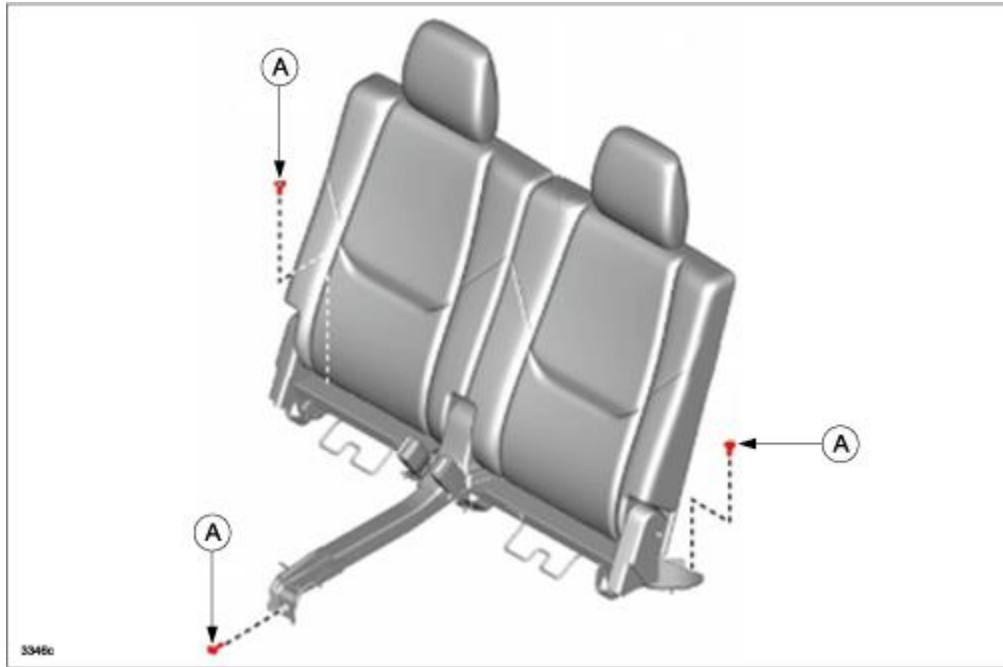

3. Verify the repair.

## PARTS INFORMATION

**NOTE:** Check the GEPC for the correct seat type/color for the subject vehicle.

**USA/Canada:**

**CONSUMER NOTICE:** The information and instructions in this bulletin are intended for use by skilled technicians. Mazda technicians utilize the proper tools/equipment and take training to correctly and safely maintain Mazda vehicles. These instructions should not be performed by "do-it-yourselfers." Customers should not assume this bulletin applies to their vehicle or that their vehicle will develop the described concern. To determine if the information applies, customers should contact their nearest authorized Mazda dealership. Mazda North American Operations reserves the right to alter the specifications and contents of this bulletin without obligation or advance notice. All rights reserved. No part of this bulletin may be reproduced in any form or by any means, electronic or mechanical---including photocopying and recording and the use of any kind of information storage and retrieval system ---without permission in writing.

Parts Number	Description	Qty.	Spec.
TK48-88-330B-02	Third-Row Seat Back Component (RH)	1	TC0 Black Cloth
TK48-88-330B-2A	" "	1	TC2 Beige Cloth
TK79-88-330B-02	" "	1	TC0 Black Leather A
TK79-88-330B-03	" "	1	TC1 Ebony/Black Leather A
TK79-88-330B-2A	" "	1	TC3 TC4 Beige - Leather A
TK81-88-330B-15	" "	1	TC5 Brown - Leather B
TK48-88-380B-02	Third-Row Seat Back Component (LH)	1	TC0 Black Cloth
TK48-88-380B-2A	" "	1	TC2 Beige Cloth
TK79-88-380B-02	" "	1	TC0 Black Leather A
TK79-88-380B-03	" "	1	TC1 Ebony/Black Leather A
TK79-88-380B-2A	" "	1	TC3 TC4 Beige - Leather A
TK81-88-380B-15	" "	1	TC5 Brown - Leather B

**Mexico:**

Parts Number	Description	Qty.	Spec.
TK56-88-330B-02	Third-Row Seat Back Component (RH)	1	TC0 Black Cloth
TK56-88-330B-2A	" "	1	TC2 Beige Cloth
TK57-88-330B-02	" "	1	TC0 Black Leather A
TK57-88-330B-03	" "	1	TC1 Ebony/Black Leather A
TK57-88-330B-2A	" "	1	TC3 TC4 Beige - Leather A
TK68-88-330B-15	" "	1	TC5 Brown - Leather B
TL06-88-380B-02	Third-Row Seat Back Component (LH)	1	TC0 Black Cloth
TL06-88-380B-2A	" "	1	TC2 Beige Cloth
TL07-88-380B-02	" "	1	TC0 Black Leather A
TL07-88-380B-03	" "	1	TC1 Ebony/Black Leather A
TL07-88-380B-2A	" "	1	TC3 TC4 Beige - Leather A
TL68-88-380B-15	" "	1	TC5 Brown - Leather B

**WARRANTY INFORMATION**

**CONSUMER NOTICE:** The information and instructions in this bulletin are intended for use by skilled technicians. Mazda technicians utilize the proper tools/equipment and take training to correctly and safely maintain Mazda vehicles. These instructions should not be performed by "do-it-yourselfers." Customers should not assume this bulletin applies to their vehicle or that their vehicle will develop the described concern. To determine if the information applies, customers should contact their nearest authorized Mazda dealership. Mazda North American Operations reserves the right to alter the specifications and contents of this bulletin without obligation or advance notice. All rights reserved. No part of this bulletin may be reproduced in any form or by any means, electronic or mechanical---including photocopying and recording and the use of any kind of information storage and retrieval system ---without permission in writing.

**NOTE:**

- This warranty information applies only to verified customer complaints on vehicles eligible for warranty repair.
- This repair will be covered under Mazda's New Vehicle Limited Warranty term.
- Additional diagnostic time cannot be claimed for this repair.

Warranty Type	A
Symptom Code	64
Damage Code	9M
Part Number Main Cause	(SEE PARTS INFORMATION TABLE)
Quantity	1
Operation Number / Labor Hours:	XXN47ARX/ 0.5Hr. (one side) XXN47CRX/ 0.6Hr. (both sides)

**CONSUMER NOTICE:** The information and instructions in this bulletin are intended for use by skilled technicians. Mazda technicians utilize the proper tools/equipment and take training to correctly and safely maintain Mazda vehicles. These instructions should not be performed by "do-it-yourselfers." Customers should not assume this bulletin applies to their vehicle or that their vehicle will develop the described concern. To determine if the information applies, customers should contact their nearest authorized Mazda dealership. Mazda North American Operations reserves the right to alter the specifications and contents of this bulletin without obligation or advance notice. All rights reserved. No part of this bulletin may be reproduced in any form or by any means, electronic or mechanical---including photocopying and recording and the use of any kind of information storage and retrieval system ---without permission in writing.