

Subject: 04-003/17 SQUEAKING/GRINDING NOISE FROM REAR BRAKE	Bulletin No.: 04-003/17
	Last Issued: 06/14/2017

BULLETIN NOTES

This bulletin supercedes the previously issued bulletin(s) listed below. 2017 Mazda3 has been removed.

Previous TSBs:	Date(s) Issued:
04-003/17	04/05/17
04-001/16	01/14/16
04-003/15	11/06/15 and 09/16/15

APPLICABLE MODEL(S)/VINS

2014-2016 Mazda3 (Japan built) vehicles with VINs lower than JM1*****355941 (produced before June 24, 2016)

DESCRIPTION

Some vehicles may experience a squeaking/grinding noise from the rear brake even after the brake pedal is released. Upon inspection, the caliper mounting support is corroded and one of the disc pad is abnormally worn out (A). This is caused by vehicle usage in an area using road salt. The surface of the mounting support may swell from corrosion causing premature disc pad wear and brake noise.

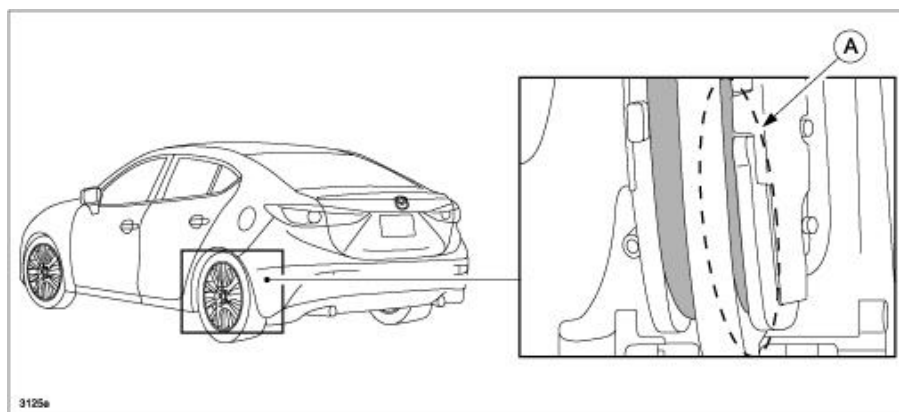

To correct the problem, an improved caliper mounting support has been newly established as a service part. The anti-corrosion surface treatment has been changed from Zn to Zn-Ni plating.

Customers having this concern should have their vehicle repaired using the following repair procedure.

CONSUMER NOTICE: The information and instructions in this bulletin are intended for use by skilled technicians. Mazda technicians utilize the proper tools/equipment and take training to correctly and safely maintain Mazda vehicles. These instructions should not be performed by "do-it-yourselfers." Customers should not assume this bulletin applies to their vehicle or that their vehicle will develop the described concern. To determine if the information applies, customers should contact their nearest authorized Mazda dealership. Mazda North American Operations reserves the right to alter the specifications and contents of this bulletin without obligation or advance notice. All rights reserved. No part of this bulletin may be reproduced in any form or by any means, electronic or mechanical---including photocopying and recording and the use of any kind of information storage and retrieval system ---without permission in writing.

REPAIR PROCEDURE

1. Verify that the caliper mounting support(s) is corroded and the disc pad(s) is abnormally worn out.
2. Replace the caliper mounting supports (both sides) with the modified service parts sets and attachments with new parts according to the instructions on MS3 online or the Workshop Manual (section 04-11 REAR BRAKE (DISC) REMOVAL/INSTALLATION).

NOTE: Replace the disc plate(s) additionally if damaged by the completely worn out disc pad.

CAUTION: When installing the modified mounting support (A), tighten the installation bolts (B) with the upper limit of the tightening torque specified in the Workshop Manual (6.6 Nm, 48 ft-lbf, 6.7 kgfm).

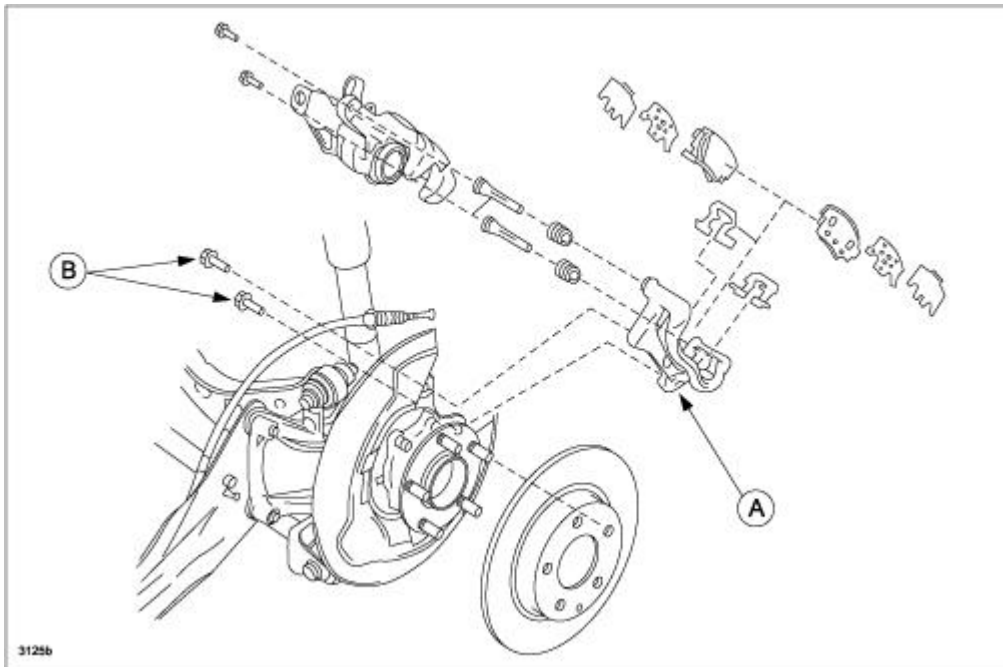

3. Verify repair.

CONSUMER NOTICE: The information and instructions in this bulletin are intended for use by skilled technicians. Mazda technicians utilize the proper tools/equipment and take training to correctly and safely maintain Mazda vehicles. These instructions should not be performed by "do-it-yourselfers." Customers should not assume this bulletin applies to their vehicle or that their vehicle will develop the described concern. To determine if the information applies, customers should contact their nearest authorized Mazda dealership. Mazda North American Operations reserves the right to alter the specifications and contents of this bulletin without obligation or advance notice. All rights reserved. No part of this bulletin may be reproduced in any form or by any means, electronic or mechanical---including photocopying and recording and the use of any kind of information storage and retrieval system ---without permission in writing.

PARTS INFORMATION

Part Number	Description	Qty.	Notes
B4YG-26-28X	Mounting Support Set	2	Newly established service parts set that includes: 1 mounting support, 2 slide pins and 2 dust boots.
B4Y0-26-43ZB	Rear Brake Pad and Attachment Set	1	Newly established service parts set that includes: pad sub set (B4Y0-26-48ZB) and pad attachment (B4Y0-26-49ZA).
B4Y0-26-48ZB	Pad Sub Set	1	DO NOT use these separate parts. Use the new part set as B4Y0-26-43ZB.
B4Y0-26-49ZA	Pad Attachment	1	
B45G-26-251A	Disc plate	1 or 2	Replace if damaged.

WARRANTY INFORMATION**NOTE:**

- This warranty information applies only to verified customer complaints on vehicles eligible for warranty repair.
- This repair will be covered under Mazda's New Vehicle Limited Warranty.
- Additional diagnostic time cannot be claimed for this repair.

Warranty Type	A
Symptom Code	82
Damage Code	9Y
Part Number Main Cause / Qty.	B4YG-26-28X / 2
Operation Number / Labor Hours:	XXL5CARX/0.5 Hrs. (Mounting support, pad sub set, pad attachment, RR both sides) XXL5CBRX/0.6 Hrs. (Mounting support, pad sub set, pad attachment, one or both disc plates, RR both sides)

CONSUMER NOTICE: The information and instructions in this bulletin are intended for use by skilled technicians. Mazda technicians utilize the proper tools/equipment and take training to correctly and safely maintain Mazda vehicles. These instructions should not be performed by "do-it-yourselfers." Customers should not assume this bulletin applies to their vehicle or that their vehicle will develop the described concern. To determine if the information applies, customers should contact their nearest authorized Mazda dealership. Mazda North American Operations reserves the right to alter the specifications and contents of this bulletin without obligation or advance notice. All rights reserved. No part of this bulletin may be reproduced in any form or by any means, electronic or mechanical---including photocopying and recording and the use of any kind of information storage and retrieval system ---without permission in writing.