



**MODEL: Karma Revero**

**DATE: September 2017**

**First Release**

**TITLE: 12 Volt Battery Testing**

**PRIORITY: All Karma Revero Vehicles**

**MARKET REGION: All**

**PURPOSE:**

In the interest of customer satisfaction, Karma Automotive (KA) is requesting that all Karma vehicles have the 12V battery tested before customer delivery.

The test plan is intended to determine the State of Health (SOH) of the 12 Volt Battery while it is installed in the vehicle. All testing is intended to be performed at standard operating temperatures using the Midtronics MDX series of testers.

The installed 12V battery is rated at 70Ah, 760CCA, and BCI group 48 H6.

**PROCESS OVERVIEW:**

1. Preparation
2. Test Procedure

**SPECIAL TOOLS REQUIRED:**

1. The Midtronics MDX-600 Series Tester (or equivalent)

**NOTE:** Before disconnecting the 12 volt battery, the drivers' door and all windows should be opened. The vehicle should be placed in PARK. The parking brake should NOT be applied.

Karma Automotive Bulletins and service documents are intended for use by experienced and trained Technicians. If you lack the skills, tools, equipment and a suitable workshop for any procedure described in this document, we suggest you leave such repairs to a Karma retailer and service provider. See your service provider for advice on whether your vehicle may benefit from the information contained within this document. The information contained in the Karma Bulletin is accurate at the date of publication. However, Karma Automotive regularly updates technical information. Please check with your Karma Automotive Retailer and Karma Automotive service provider that the bulletin you intend to use contains the latest available information.

**MODEL: Karma Revero**

**DATE: September 2017**

**First Release**

### TITLE: 12 Volt Battery Testing

Battery testing will be performed directly on the battery, in place (behind the right front wheel).

- 1) Power off- wait for car to go to sleep (45 seconds to one (1) minute)
- 2) Disconnect #10 solar panel fuse; "SPBC and HVAC"



- 3) Disconnect the 12 volt main connector (under hood- on right fender)

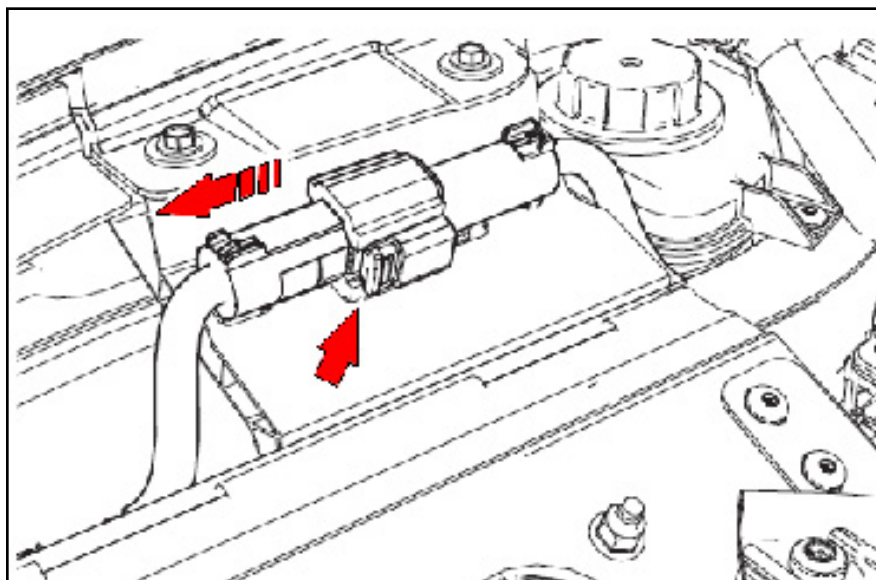

Karma Automotive Bulletins and service documents are intended for use by experienced and trained Technicians. If you lack the skills, tools, equipment and a suitable workshop for any procedure described in this document, we suggest you leave such repairs to a Karma retailer and service provider. See your service provider for advice on whether your vehicle may benefit from the information contained within this document. The information contained in the Karma Bulletin is accurate at the date of publication. However, Karma Automotive regularly updates technical information. Please check with your Karma Automotive Retailer and Karma Automotive service provider that the bulletin you intend to use contains the latest available information.

MODEL: Karma Revero

DATE: September 2017

First Release

## TITLE: 12 Volt Battery Testing

**NOTE:** If the 12 volt battery has been disconnected; use the mechanical key to open the right-front door and gain entry to the vehicle, if required.

- 4) Turn the steering wheel completely to the right to provide some working area, and lower the fender liner to access the battery
- 5) Connect the leads from the tester to the corresponding battery terminals (voltage reading needs to be 12.5V or higher)

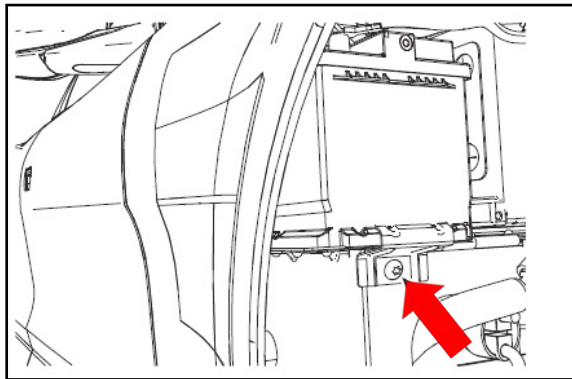

- 6) If the battery failed the in-vehicle test. Remove the wheel, remove the battery bracket (bracket torque is 8 +/- 1.5 Nm), remove the cables- fastening torque is 10.0 +/- 1.5Nm on the positive side and 7.0 +/- Nm on the negative cable, slide the battery out for testing

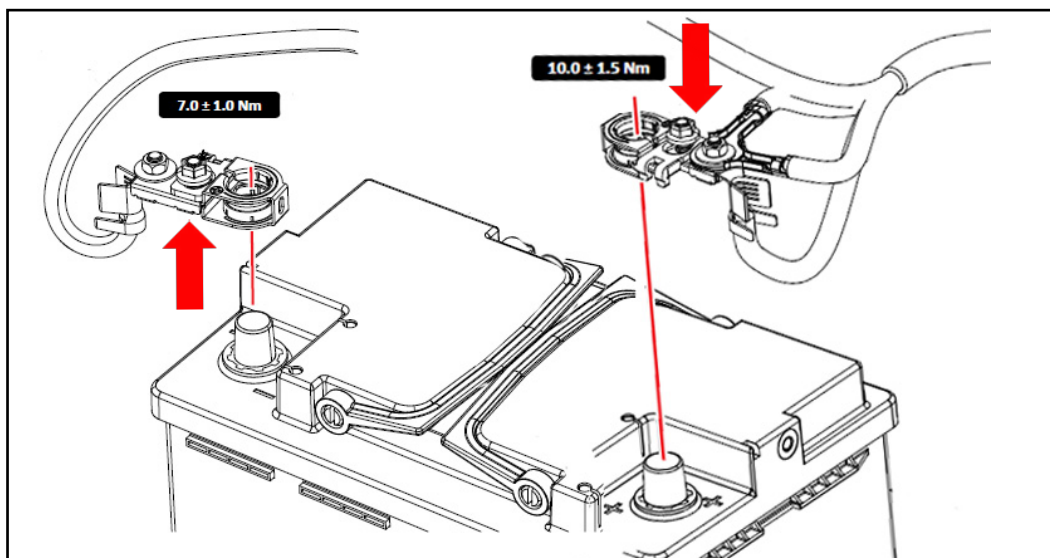

Karma Automotive Bulletins and service documents are intended for use by experienced and trained Technicians. If you lack the skills, tools, equipment and a suitable workshop for any procedure described in this document, we suggest you leave such repairs to a Karma retailer and service provider. See your service provider for advice on whether your vehicle may benefit from the information contained within this document. The information contained in the Karma Bulletin is accurate at the date of publication. However, Karma Automotive regularly updates technical information. Please check with your Karma Automotive Retailer and Karma Automotive service provider that the bulletin you intend to use contains the latest available information.



**MODEL: Karma Revero**

**DATE: September 2017**

**First Release**

**TITLE: 12 Volt Battery Testing**

- 7) Connect the Midtronics tester as instructed by the user manual

The test should show a battery operating as normal, if the battery is below 12.5V, charge the battery and retest, if this fails again replace the battery. The charge rate is 40A for 30minutes or 10amps for 2 hours.

NOTE: *IF* measured at the fuse box and the chassis ground the battery must measure above 12.3V. Direct battery testing is the procedure recommended.

- 8) At completion of a successful test, or installation of a new battery
- Reconnect 12 volt main connector
  - Reinstall Fuse #10 for solar roof (SPBC)
  - Calibrate Park Brake
  - Initialize all four (4) windows

For any failed 12V battery provide a printout or a copy of the readings (image for TSS case and warranty submission)

Normal warranty rates and codes apply.

Karma Automotive Bulletins and service documents are intended for use by experienced and trained Technicians. If you lack the skills, tools, equipment and a suitable workshop for any procedure described in this document, we suggest you leave such repairs to a Karma retailer and service provider. See your service provider for advice on whether your vehicle may benefit from the information contained within this document. The information contained in the Karma Bulletin is accurate at the date of publication. However, Karma Automotive regularly updates technical information. Please check with your Karma Automotive Retailer and Karma Automotive service provider that the bulletin you intend to use contains the latest available information.