

MODEL: Karma Revero**DATE:** September 2017**TITLE:** Intercooler Charge Air Pipe Inspection**First Release****PRIORITY:** On Complaint**APPLICABILITY:** MY17 and MY18 Revero**MARKET REGION:** North America**PURPOSE:** Inspect the intercooler hose clamp for proper alignment

The complaint will vary in presentation through diagnostic trouble codes related to air/fuel ratio imbalance or underboost condition. Inspect the hose clamps for the intake system and ensure they are lined up correctly and all hoses are located properly. Loosening of the clamp to adjust the hose may be required. Reinstall to the specified torque value (8.5 +/- 0.5Nm).

A visual inspection may show a misaligned clamp and hose immediately, this will require action (fig.1a and 1b).



fig.1a



fig.1b

NOTE: This is from the underside of the vehicle. The other clamps are accessible from the top

Karma Automotive Bulletins and service documents are intended for use by experienced and trained Technicians. If you lack the skills, tools, equipment and a suitable workshop for any procedure described in this document, we suggest you leave such repairs to a Karma retailer and service provider. See your service provider for advice on whether your vehicle may benefit from the information contained within this document. The information contained in the Karma Bulletin is accurate at the date of publication. However, Karma Automotive regularly updates technical information. Please check with your Karma Automotive Retailer and Karma Automotive service provider that the bulletin you intend to use contains the latest available information.

TB-17-12-19**MODEL: Karma Revero****DATE: September 2017****TITLE: Intercooler Charge Air Pipe Inspection****First Release**

These clamps are shown correctly installed (fig. 2a and 2b).

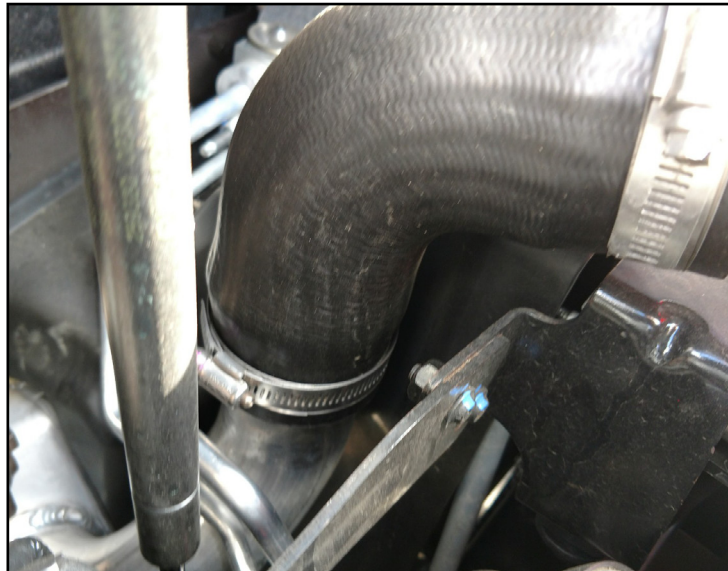

fig.2a



fig.2b

Karma Automotive Bulletins and service documents are intended for use by experienced and trained Technicians. If you lack the skills, tools, equipment and a suitable workshop for any procedure described in this document, we suggest you leave such repairs to a Karma retailer and service provider. See your service provider for advice on whether your vehicle may benefit from the information contained within this document. The information contained in the Karma Bulletin is accurate at the date of publication. However, Karma Automotive regularly updates technical information. Please check with your Karma Automotive Retailer and Karma Automotive service provider that the bulletin you intend to use contains the latest available information.

MODEL: Karma Revero**DATE: September 2017****First Release****TITLE: Intercooler Charge Air Pipe Inspection**

For guidance: the hose clamps to be first considered are the red indicated clamps at the intercooler in the image (fig 3). Any additionally clamps found to be misaligned will required images and a TSS case submission.

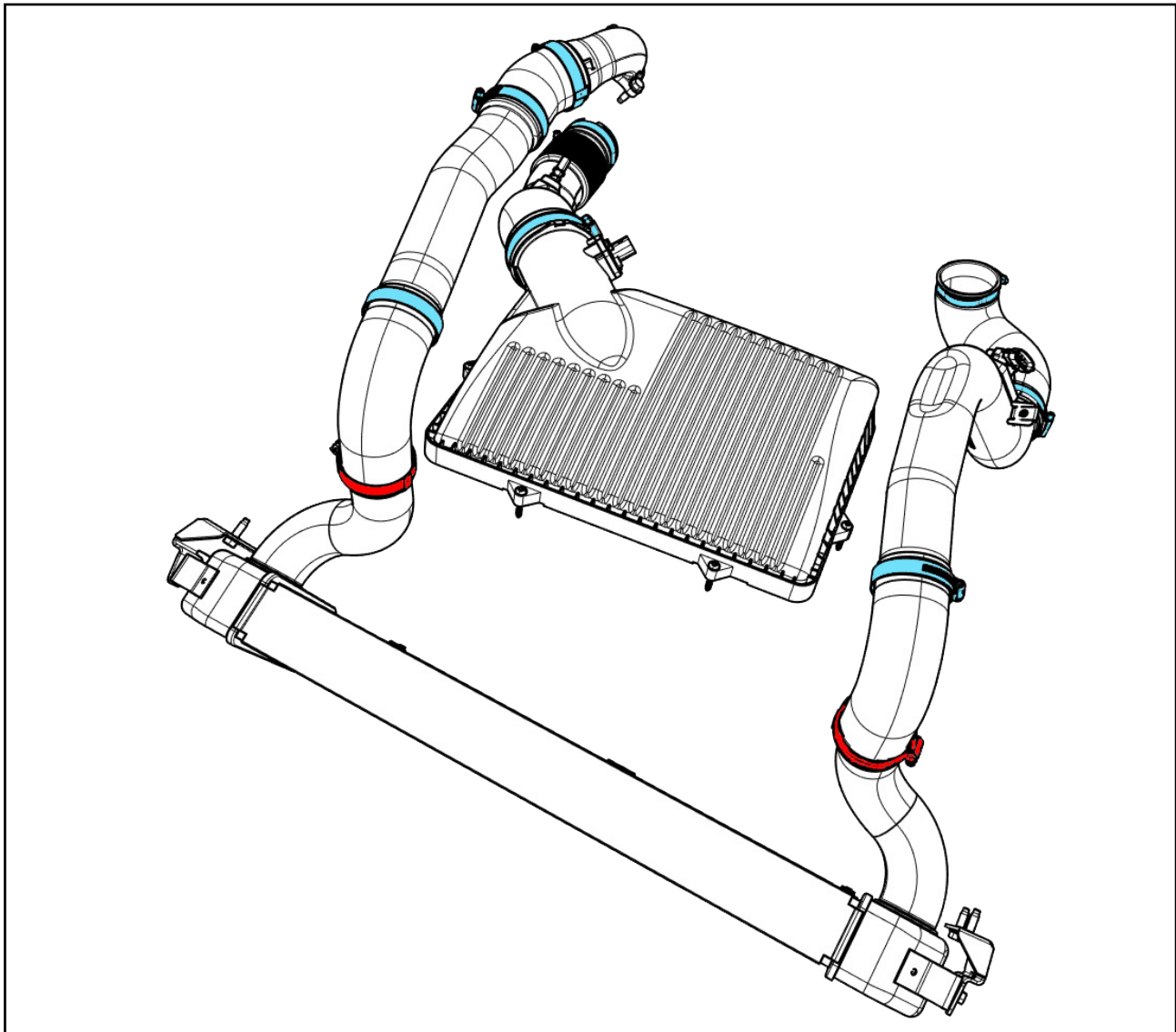

fig.3

Karma Automotive Bulletins and service documents are intended for use by experienced and trained Technicians. If you lack the skills, tools, equipment and a suitable workshop for any procedure described in this document, we suggest you leave such repairs to a Karma retailer and service provider. See your service provider for advice on whether your vehicle may benefit from the information contained within this document. The information contained in the Karma Bulletin is accurate at the date of publication. However, Karma Automotive regularly updates technical information. Please check with your Karma Automotive Retailer and Karma Automotive service provider that the bulletin you intend to use contains the latest available information.



Service Communication

TB-17-12-19

MODEL: Karma Revero

DATE: September 2017

First Release

TITLE: Intercooler Charge Air Pipe Inspection

PARTS REQUIRED:

PART NUMBER	DESCRIPTION	QTY
N/A		

SHOP SUPPLIES:

DESCRIPTION
N/A

SPECIAL TOOLS:

DESCRIPTION
N>A

CAUSAL PART:

PART NUMBER	DESCRIPTION
C131114414002	CAC Clamp

LABOR CODES:

CODE	DESCRIPTION	TIME	DEFECT CODE
12-70-20-00	Clamp - Charge Air Cooler Outlet R&R	0.1	12-70-20-11

SUBLET:

CODE	DESCRIPTION	AMOUNT
N/A		

WARRANTY DISPOSITION: This repair is covered under the New Vehicle Limited Warranty, in effect for five (5) years from the in-service date with no mileage limitation.

Karma Automotive Bulletins and service documents are intended for use by experienced and trained Technicians. If you lack the skills, tools, equipment and a suitable workshop for any procedure described in this document, we suggest you leave such repairs to a Karma retailer and service provider. See your service provider for advice on whether your vehicle may benefit from the information contained within this document. The information contained in the Karma Bulletin is accurate at the date of publication. However, Karma Automotive regularly updates technical information. Please check with your Karma Automotive Retailer and Karma Automotive service provider that the bulletin you intend to use contains the latest available information.