



**RECREATIONAL VEHICLE SERVICE CAMPAIGN**

August 18, 2017

**SERVICE ADVISORY 17-294**

«Owner\_name»  
ATTN: Service Manager  
«Street»  
«Street\_2»  
«City», «State» «Zip»  
«Country»

Dear «Owner\_name»,

***Reason for this campaign*** It has been determined that on some 2017-2018 Coleman 1755 models built in plant 840, a furnace return vent was not installed.

The campaign population includes:

**Models:** 2017 – 2018 Coleman: 1755  
**Serial Number Ranges:** 2017 - HM936705, HM938052  
2018 - JM931316 – JM932097

Our records indicate unit(s) sold or in your present lot inventory fall within this range, which will require inspection. **Important:** Please complete the service campaign on these units before retail delivery. Our records indicate the following unit serial number(s) are presently in your inventory or have been sold:

«VIN1» «VIN2»  
-- Serial numbers with '\*' have been retail sold --

We apologize for any inconvenience this situation may cause and greatly appreciate your cooperation. Should you have any questions or concerns regarding this correspondence or the attached Service Advisory, please contact us at: **(855) 895-4422**

Sincerely,

**KEYSTONE RV COMPANY**

Rick Deisler  
Vice President Service Operations

**PO Box 2000 Goshen, IN 46527-2000**  
**Phone: (574) 535-2100 – Fax: (574) 535-2199**  
**www.keystonerv.com**



## RECREATIONAL VEHICLE SERVICE CAMPAIGN

August 18, 2017

Service Advisory: 17-294

### **SERVICE CAMPAIGN**

«Owner\_name»  
«Street»  
«Street\_2»  
«City», «State» «Zip»  
«Country»

VIN: «VIN»

Dear «Owner\_name»:

Keystone RV Company is conducting a service campaign on certain 2017-2018 Dutchmen Coleman Travel Trailers. We apologize for any inconvenience this action may cause you; however your continued satisfaction is of the utmost importance to us.

#### ***Reason for this campaign***

It has been determined that on some 2017-2018 Coleman 1755 models built in plant 840, a furnace return vent was not installed.

#### ***What we will do***

Keystone has notified our dealers regarding this situation. The remedy is to install a return vent. The service required for this corrective action will be provided at no charge to you.

#### ***What we need you to do***

At your earliest convenience, please make an appointment to have your RV serviced by your dealership. The labor time to perform this campaign is approximately ½ hour. Please ask your dealer if you wish to know how much additional time will be needed to schedule and process your RV for this repair.

#### ***If you have questions***

Your dealer is best equipped to obtain parts and provide service to ensure your RV is corrected as promptly as possible. If your dealer is unable to assist or if you take your RV to your dealer on the agreed service date, and the dealer does not remedy the condition within a reasonable amount of time, or without charge to you, please contact Keystone Customer Service by calling 1-866-425-4369.

Thank you for your attention and cooperation in this matter.

Sincerely,

**KEYSTONE RV COMPANY**

Rick Deisler  
Vice President Service Operations

## SERVICE ADVISORY # 17-294

### Coleman 1755 Furnace Return Vent

It has been determined that on some 2017-2018 Coleman 1755 models built in plant 840, a furnace return vent was not installed. This advisory explains how to correct the problem if it exists.

- Models Included:** 2017 – 2018 Coleman: 1755
- Serial Number Range:** 2017 - HM936705, HM938052  
2018 - JM931316 – JM932097
- Parts Required:** 1-pc 439470 - Furnace - Vent Kit - Direct - Black - Door Application  
4 pcs - #8 screws less than 1" purchased locally
- Tools Required:** - Utility knife or jig saw – Screw gun

**Note – Check serial number on Key Express to verify the campaign is open.**

When performing warranty or recall service, please make certain that appropriate Personal Protective Equipment (PPE) is used.

### Inspect and Repair

#### Step 1

Locate the furnace under the dinette seat on the off-door-side towards the front of the unit, Figure 1.

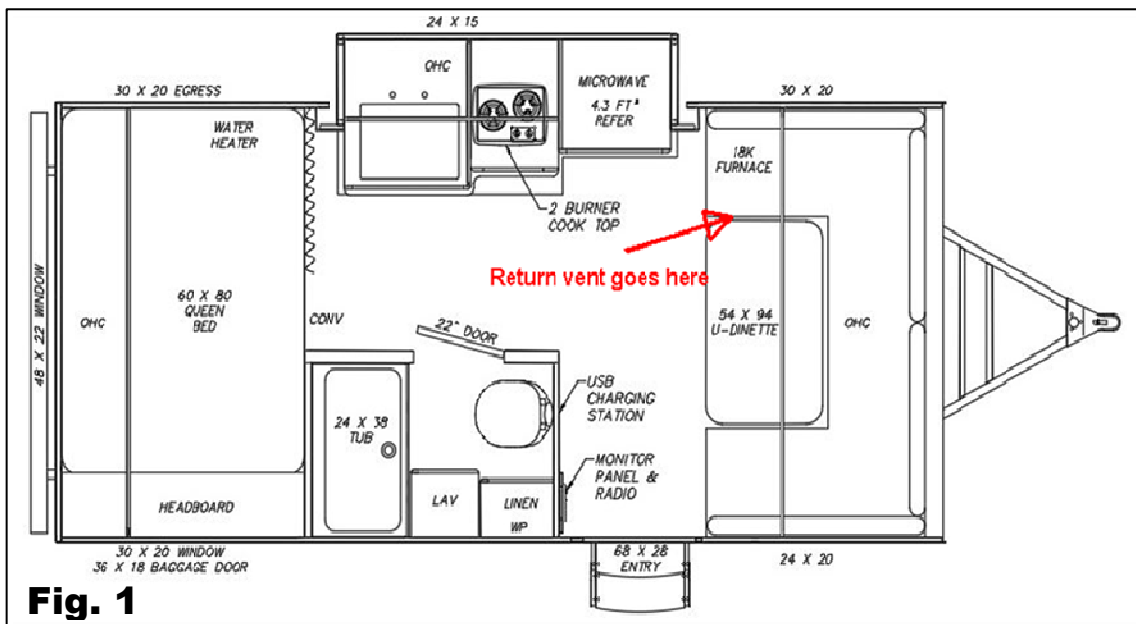

**Step 2**

The return vent hole will need to be centered in front of the furnace in the seat base. Remove the seat to cut a hole 8  $\frac{3}{4}$ " high by 12  $\frac{1}{2}$ " wide for the return vent carefully using a jig saw or utility knife, Figure 2.

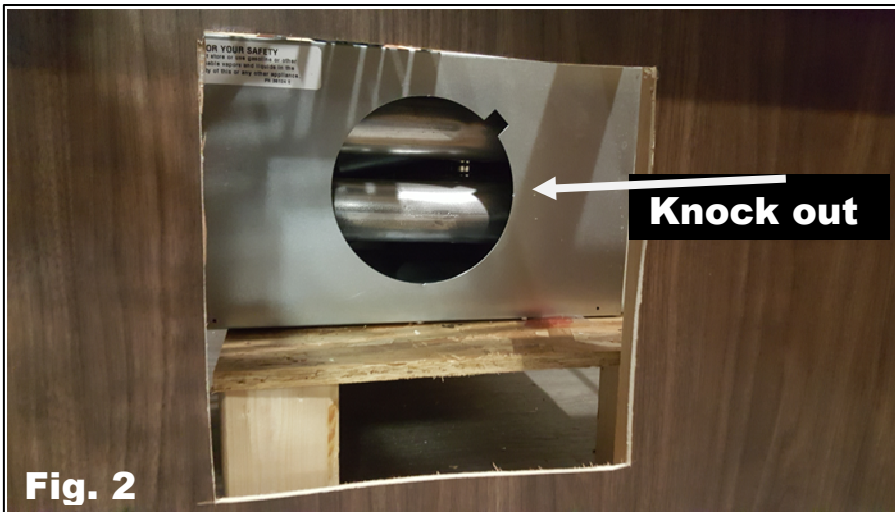
**Step 3**

Install the furnace vent kit 439470 following these steps (Figure 3):

1. Install adapter by removing the large knock out from the rear of the furnace casing (as seen in Figure 2) and attach the 5" duct adapter.
2. Fasten the supplied duct to the adapter and to the back of the interior grill assembly and secure using 2 screws (#8 under 1") at each attachment. Reference Figure 3.

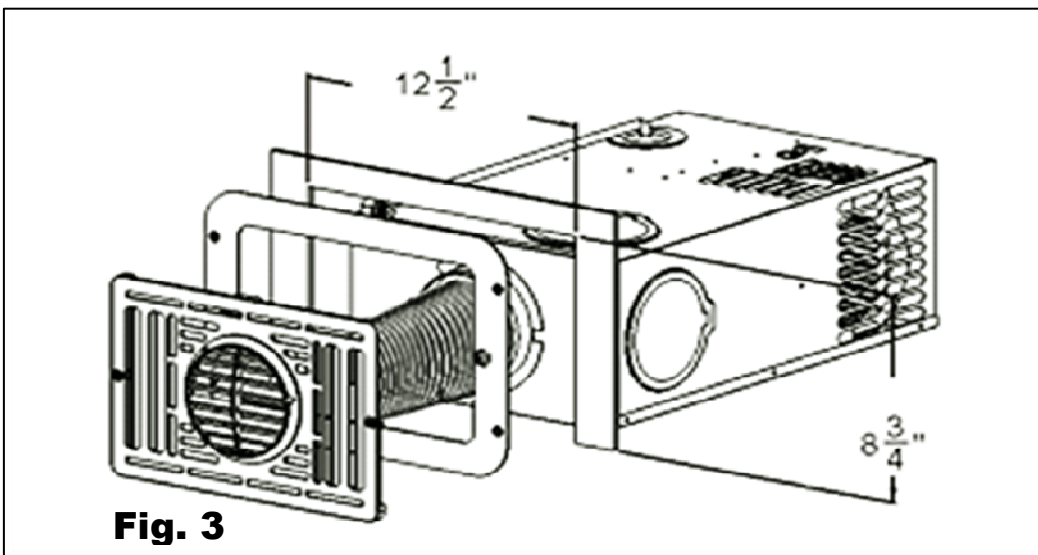

3. Secure the grill to the seat base as shown in Figure 4.



**Step 4**

Proceed to warranty reimbursement.

**WARRANTY REIMBURSEMENT**

Submit the claim on Key Express using **Flat Rate Code # 7129442K** with **Safety Advisory # 17-294** noted in the customer complaint section. The amount of time authorized for repair is **0.5 hour**.

If you have questions, please contact Customer Service: **(855) 895-4422**