

Refuse Deflector Installation for Agility 75 DGE CNG Roof Mounted Systems

Date: August 9, 2017
Bulletin Name: FEL-TSIB-049
Model: Atlantic FEL 29
Model Year: 2011 - Current
Units Affected: Agility CNG Roof Mounted Systems

Purpose:

The following instructions are for installing a refuse deflector system on a 75 DGE Agility roof mounted Compressed Natural Gas (CNG) system to help prevent debris build-up between the back of the hopper deflector and the CNG cabinets.

Notice:

- This bulletin should be read and understood in its entirety before performing this procedure.
- All procedures outlined in the bulletin must be performed by skilled service personnel. Refer to the product service manual for descriptions of maintenance procedures.

SAFETY NOTICE

Use appropriate Personal Protective Equipment (PPE) as required by your company.

SAFETY NOTICE

Perform your company's Lockout/Tagout procedure. If your company does not have a Lockout/Tagout procedure, follow OSHA 1910.147 and 1910.146 Confined Space as appropriate.

Equipment Required:

Customer to supply:

- Ladder
- Torque wrench
- Wrenches
- Overhead crane or other lifting system with slings rated for a minimum of 200 lbs
- Machinist's marker
- Electric drill and drill bit
- 3/8" to 1/2" thick spacer (wood block or scrap piece of steel) - quantity 2

Parts Required:

Item	P/N	Description	Qty.
1	1559515	WELDMENT, 75 DGE CNG ROOF MOUNTED REFUSE DEFLECTOR	1
2	1243637	SCR, FLG, HEX .38-16X1.25 G8 ZY	4

Procedure:

1. Two people are required to perform this procedure.
2. Place vehicle on a flat surface, block truck tires.
3. Close the top door using the in-cab controls.
4. Perform your company's Lockout/Tagout procedure. If your company does not have a Lockout/Tagout procedure, follow OSHA 1910.147 and 1910.146 Confined Space as appropriate.
5. Disconnect vehicle battery (see information below for disconnecting the battery).

Battery Disconnect Procedures

Battery Disconnect Switch

- If the vehicle is equipped with a battery disconnect switch, it is located near the battery box. Use the battery disconnect switch when performing any maintenance so the vehicle cannot be accidentally started.
 1. Turn the battery disconnect switch (Figure A, Item 1) counterclockwise so the hole on the switch aligns with the hole in the bracket (Figure A, Item 2).
 2. Install the safety lockout device ring (Figure B, Item 1) through the holes on the battery disconnect switch and the bracket.
 3. Install a padlock (Figure B, Item 2) onto the safety lockout device ring, lock it, and put the key in your pocket. If more than one person is working on the vehicle, each person must install his or her own padlock.

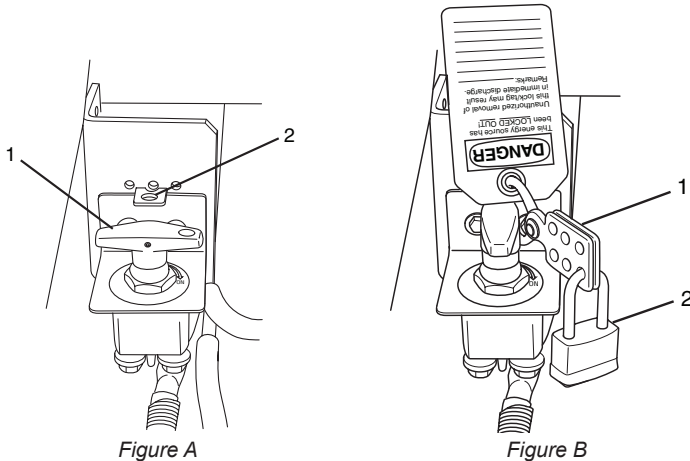

Battery Cables

- If the vehicle is not equipped with a battery disconnect switch, disconnect the negative (black) battery cable first, then the positive (red) cable.

⚠ WARNING

For trucks without a battery disconnect switch, to prevent accidental vehicle start-up, which could cause death or serious injury, disconnect battery cables (negative cable first) before proceeding.

Disconnect negative (-) battery cable first. If positive (+) cable should contact ground with negative (-) cable connected, the resulting sparks can cause a battery explosion, which could result in death or serious injury.

3. Attach the slings and overhead crane (as necessary) and remove the existing deflector and hardware (from both sides) (Figure 1). Retain the hardware - some will be reused during installation of the new refuse deflector weldment.

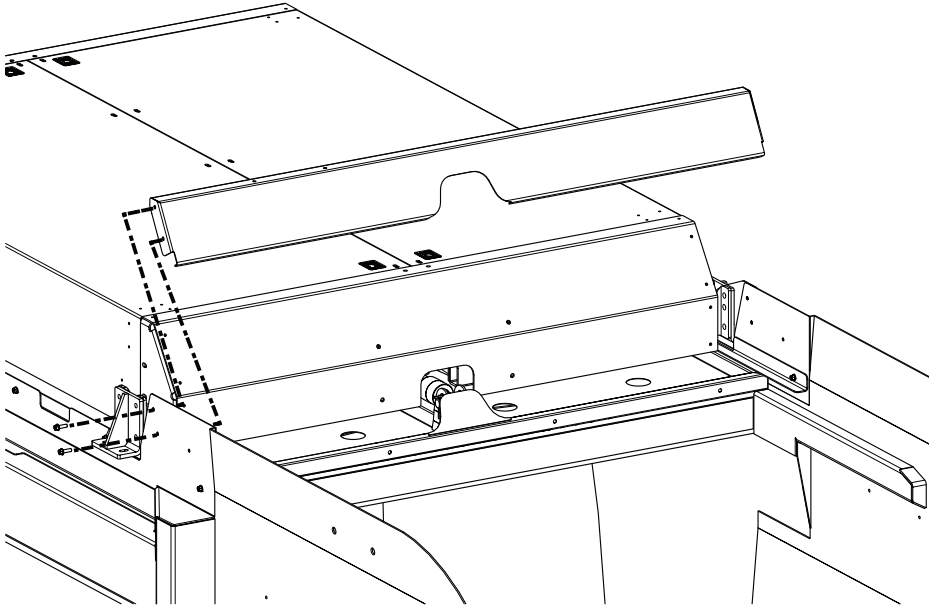

Figure 1

4. Remove and discard the four bolts from the top of the CNG cover system (Figure 2).

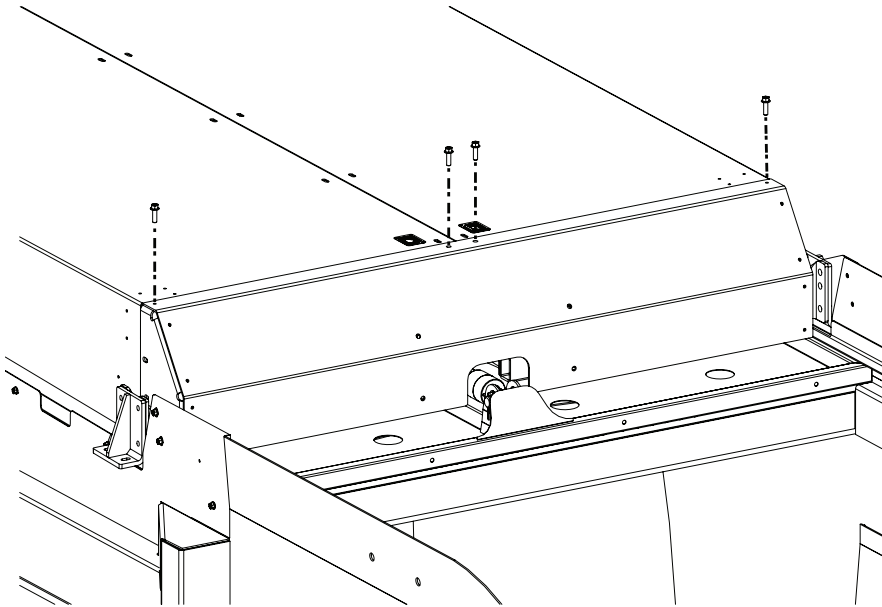

Figure 2

5. Attach the slings and overhead crane to the new refuse deflector weldment (P/N 1559515).
6. Move the refuse deflector weldment into position at the roof mounted CNG system (Figure 3). Position the weldment so the bolt holes across the top align with the bolt holes on the top of the CNG system cover.

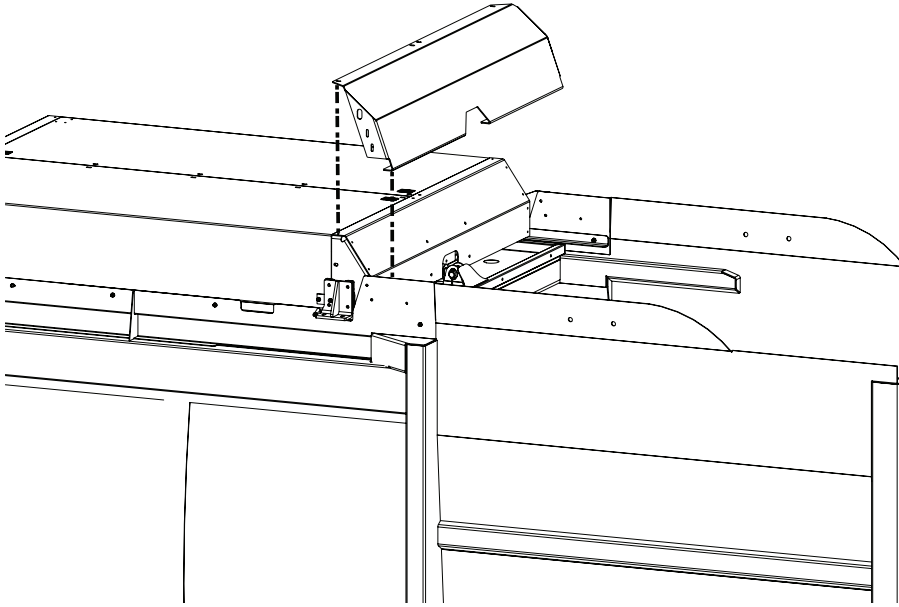

Figure 3

7. Install four bolts (P/N 1243637) across the top of the refuse deflector weldment to secure the weldment to the CNG cover (location shown in Figure 4). Tighten the bolts enough to hold the deflector in place, but do not over-tighten. The bolts are being installed at this time to keep the deflector aligned during the next few steps.

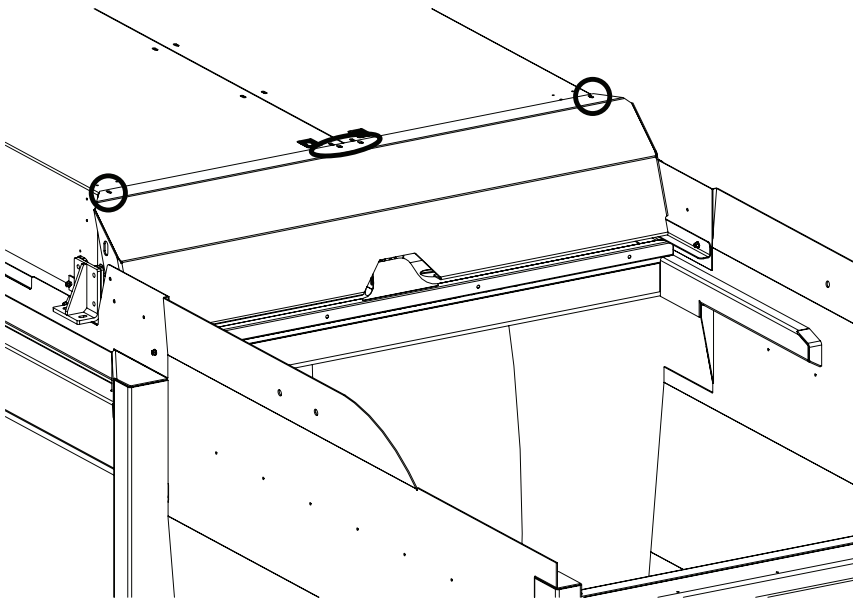

Figure 4

8. Remove your company's Lockout/Tagout procedure. If your company does not have a Lockout/Tagout procedure, follow OSHA 1910.147 and 1910.146 Confined Space as appropriate.
9. Use the in-cab controls to open the top door until it lines up with the new refuse deflector weldment and the horizontal top door tube.
10. Perform your company's Lockout/Tagout procedure. If your company does not have a Lockout/Tagout procedure, follow OSHA 1910.147 and 1910.146 Confined Space as appropriate.
11. Insert the spacers between the top door tube and the refuse deflector weldment. The purpose of the spacers is to keep the correct amount of clearance between the tube and the deflector when installing the deflector.

12. Use a machinist's marker to mark the new deflector bolt holes (marking from the inside) (Figure 5 - one side shown for illustrative purposes only). Do this on both inside sides.

NOTE: A set of dimensions for the new deflector bolt holes is available in Appendix A as a secondary reference.

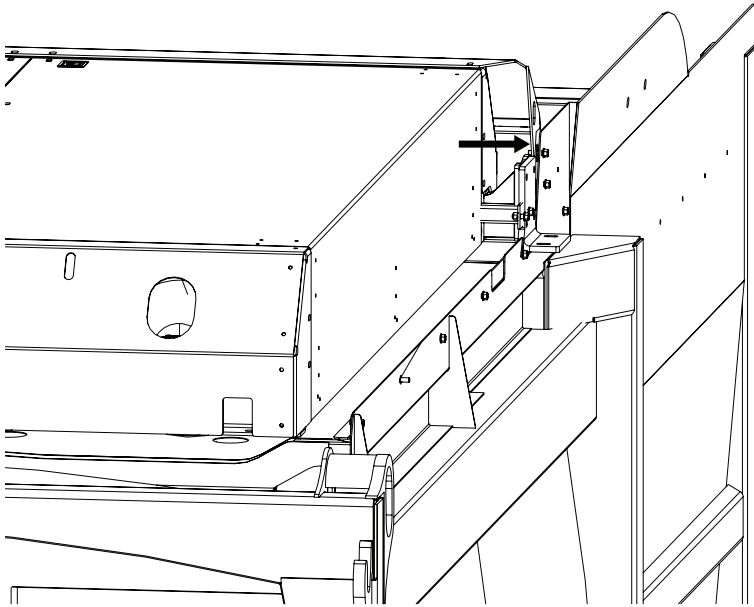

Figure 5

13. Remove and retain the four bolts from the top of the deflector.

14. Remove and retain the refuse deflector weldment.

15. Use an electric drill to drill the bolt holes.

16. Reinstall the refuse deflector weldment (Figure 3).

17. Reinstall four bolts (P/N 1243637) across the top of the refuse deflector weldment to secure the weldment to the CNG cover (location shown in Figure 4).

18. Use a torque wrench to torque the bolts to 40 ft.-lbs.

19. Reinstall two bolts and two nuts on each side of the refuse deflector weldment to secure the weldment to the windguards (Figure 6).

- **TIP:** There is enough clearance to reach your hand in from the rear of refuse deflector weldment between the deflector weldment and the CNG system to install and tighten the nuts.

20. Use a torque wrench to torque the bolts to 40 ft.-lbs.

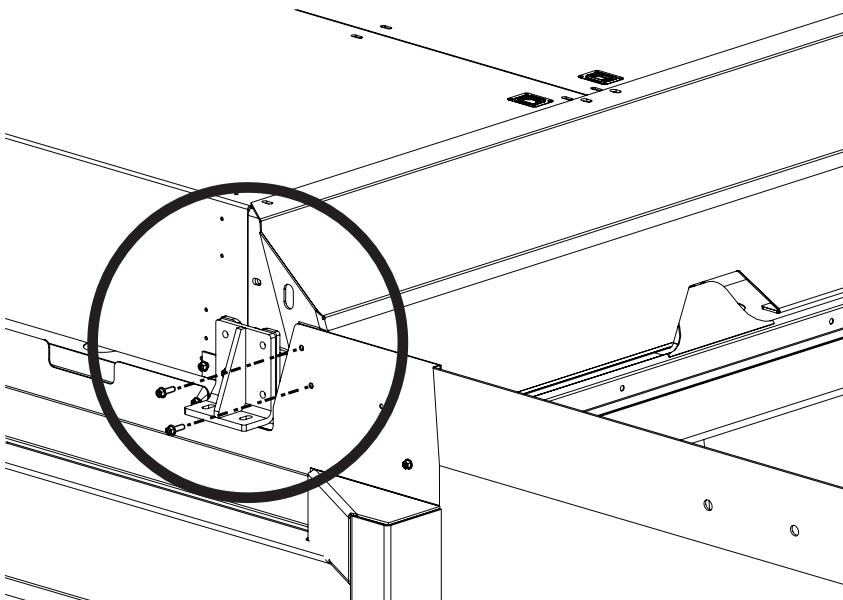

Figure 6

21. Installation procedure is complete.
22. Reconnect the vehicle's battery and remove your company's Lockout/Tagout procedure. If your company does not have a Lockout/Tagout procedure, follow OSHA 1910.147 and 1910.146 Confined Space as appropriate.
23. Use the in-cab controls to activate the top door from the cab control box and run it open and closed a few times to ensure it clears the refuse deflector weldment.
 - If the top door does not function or hits the deflector weldment, call a McNeilus National Service Representative at 888-686-7278 for assistance.

Continuous Improvement:

The change included in this bulletin is part of the McNeilus® Continuous Improvement Process.

McNeilus® Company's quality policy is Providing Customer Satisfaction through Innovative Products, Dedicated Service, and a constant focus on Continuous Improvement.

"The Customer is our Boss!"



(888) 686-7278

www.streetsmartparts.com

Appendix A

1. If desired, use the dimensions in Figure 1 as a secondary reference when determining where to mark and drill the new bolt holes to attach the deflector to the side windguards.
2. Use a machinist's marker to mark the dimensions as shown in Figure 1 to drill new bolt holes.
3. Use an electric drill to drill the bolt holes.
4. Repeat Steps 2 and 3 to the windguard on the other side of the vehicle.

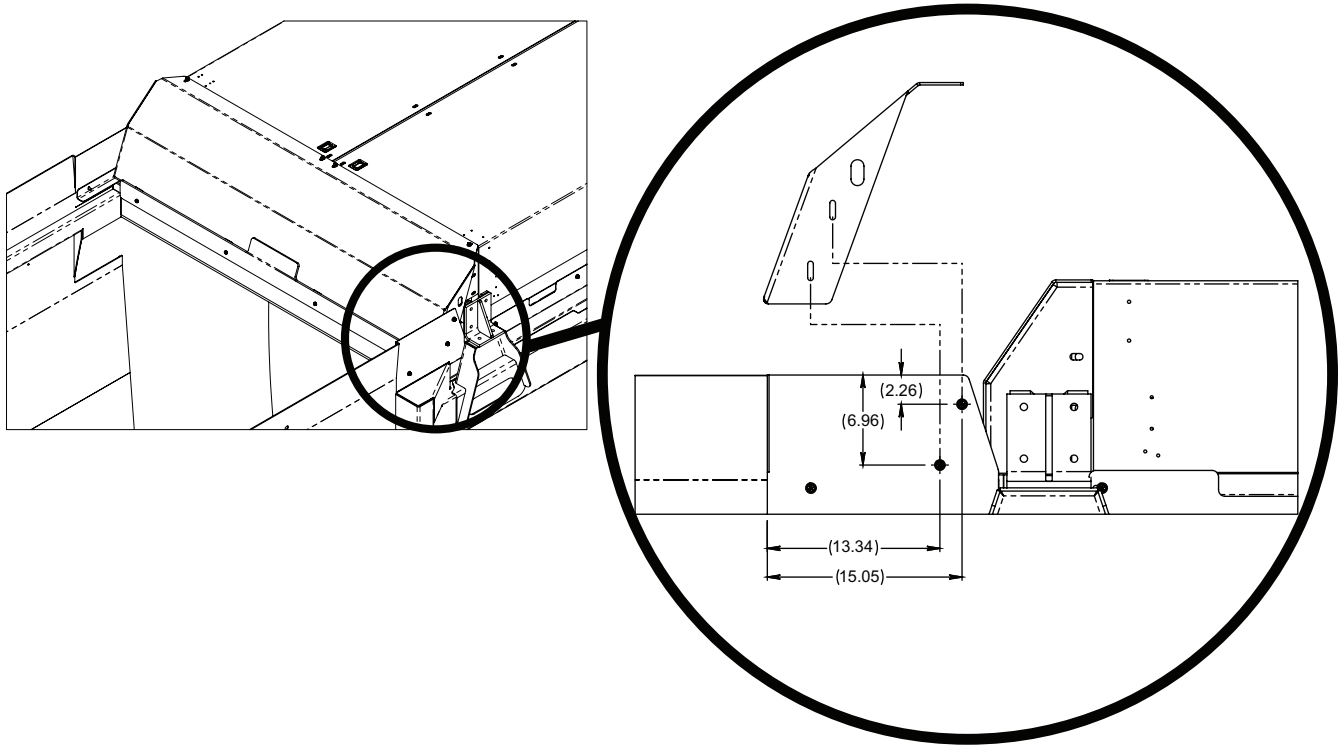

Figure 1