

### External Body Service Lift Bolt Installation for Pacific Ultra FEL

Date: August 30, 2017

Bulletin Name: FEL-TSIB-051

Models: Pacific Ultra FEL 76

Model Year: 2014-2017

Units Affected: Vehicles with external body service lifts

### Purpose:

Part of the daily pre-trip inspection is to inspect the external body service lift pins, cylinders, and other components. If any component is damaged or missing, then that component must be replaced. This TSIB is informing you that you can replace the snapper pin with a bolt and nut.

### Notice:

- This bulletin should be read and understood in its entirety before performing this procedure.
- All procedures outlined in the bulletin must be performed by skilled service personnel. Refer to the product service manual for descriptions of maintenance procedures.

### SAFETY NOTICE

Perform your company's Lockout/Tagout procedure. If your company does not have a Lockout/Tagout procedure, follow OSHA 1910.147 and 1910.146 Confined Space as appropriate.

### SAFETY NOTICE

Use appropriate Personal Protective Equipment (PPE) as required by your company.

### Equipment Required:

Customer to supply:

- Impact wrench

### Parts Required:

Purchase from McNeilus Truck and Manufacturing, Inc. by calling 888-686-7278 or visiting [www.streetsmartparts.com](http://www.streetsmartparts.com).

Item	P/N	Description	Qty.
1	1136604	BOLT, CAP, HEX .38-16X2.25 G8 ZY	2
2	0120177	NUT, HEX, LKDT .38-16 GC ZC	2
3	1466063	Service Lift Weldment Top Pin (if necessary) (Cylinder Pin)	1-2

**Procedure:**

1. Perform your company's Lockout/Tagout procedure. If your company does not have a Lockout/Tagout procedure, follow OSHA 1910.147 and 1910.146 Confined Space as appropriate.
2. Locate the body service lifts under the vehicle body (Figure 1).

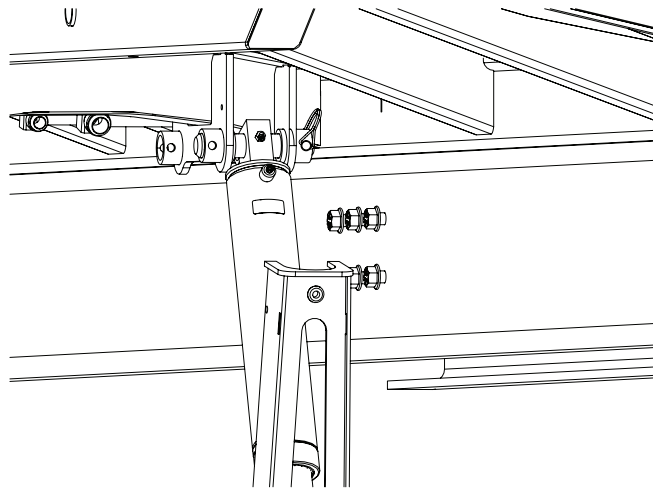

Figure 1

3. Inspect if the cylinder pin (Figure 2, Item 1) is installed for the upper cylinder assembly. (Inspect both service lift cylinder assemblies.)
  - If the cylinder pin is missing or damaged, order the replacement part before proceeding with this installation instruction. Vehicle cannot be used in service until all parts are installed.
4. Remove the round snapper pin (Figure 2, Item 2) from the upper pin on the body lift cylinder. Discard the snapper pin.

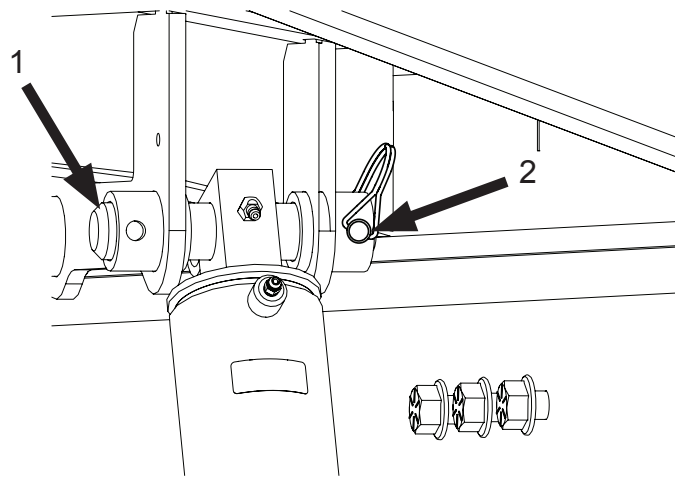

Figure 2

5. Install replacement cylinder pin as needed.

6. Insert the bolt through the hole on the collar of the body lift lug and cylinder pin (Figure 3).
7. Install the nut and tighten until it is secure on the bolt using the impact wrench.
8. Repeat Steps 4 through 7 to the service lift cylinder on the other side of the vehicle.

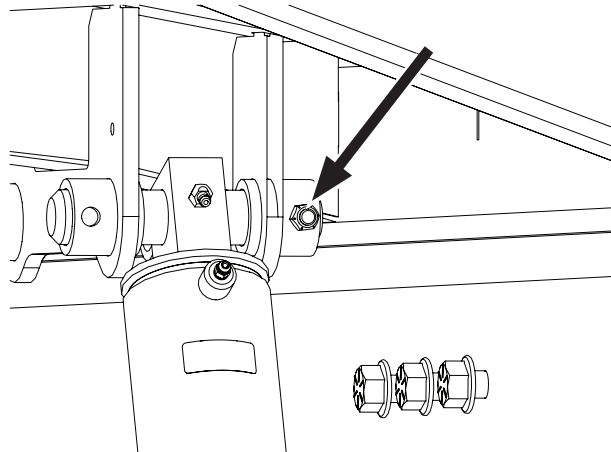

Figure 3

9. Once both sides have been completed, remove your company's Lockout/Tagout procedure. If your company does not have a Lockout/Tagout procedure, follow OSHA 1910.147 and 1910.146 Confined Space as appropriate.
10. Refer to the Preventive Maintenance schedule for body service lift in the operator's or service manuals.
11. The procedure is complete.
12. Return the vehicle to service.

### Continuous Improvement:

The change included in this bulletin is part of the McNeilus® Continuous Improvement Process.

*McNeilus® Company's quality policy is Providing Customer Satisfaction through Innovative Products, Dedicated Service, and a constant focus on Continuous Improvement.*

***"The Customer is our Boss!"***



**(888) 686-7278**

**[www.streetsmartparts.com](http://www.streetsmartparts.com)**