

**Updated Zero Radius Wrapped Hydraulic
Hose Assembly for the Arm**

Date: May 8, 2017
Bulletin Name: WM-TSB-039-D
Model: Zero Radius
Model Years: 2010 to current

Purpose:

McNeilus Truck and Manufacturing offers an updated hydraulic hose wrapped assembly for the Zero Radius arm that will replace current versions. This hose assembly has a sleeve around the hoses and electrical harness to keep the hoses and harness together, away from the motion of the grabber on the arm.

Notice:

- This bulletin should be read and understood in its entirety before performing this procedure.
- All procedures outlined in the bulletin must be performed by skilled service personnel. Refer to the product service manual for descriptions of maintenance procedures.
- This bulletin is confidential and limited to exclusive distribution within Waste Management.

SAFETY NOTICE

Perform your company's Lockout/Tagout procedure. If your company does not have a Lockout/Tagout procedure, follow OSHA 1910.147 and 1910.146 Confined Space as appropriate.

Tools and Equipment Required:

- 1/2" socket wrench
- 7/32" Allen wrench
- 1" wrench
- Zip Ties
- 11/16" wrench
- Loctite® 545 thread sealant or equivalent
- 7/8" wrench
- Red or blue Loctite® or equivalent
- 13/16" wrench
- Hydraulic oil collection container
- 9/16" socket wrench

Parts Required (Order from McNeilus):

Item	Part Number	Description	Qty.
1	1563274	Kit ZR arm hydraulic hose wrapped assembly	—
1	1541560	Hose assembly with sleeve	1
2	1131607	ADPT-AQP,2061-10-8SAC	2
3	1509942	Hose Abrasion Control Bracket	1
4	1509941	Nylon Hose Abrasion Control Rod	1
5	1543297	SCR, BTN, SOC .38-16 X 2.75 835 BO	2
6	1561880	Hydraulic Tube Clamp Angle	1
7	1562532	LOOM, .75, WIRE HARNESS, ZR ARM	1

This bulletin is limited to Waste Management Use Only.

This bulletin is limited to Waste Management Use Only.

Procedure:

1. Place unit on a flat surface, block truck tires, disconnect the battery, and observe all conditions of the Safety Notice concerning Lockout/Tagout posted in the Notice section of this bulletin.
2. Remove grabber cover (Figure 1). Retain all hardware and the cover.

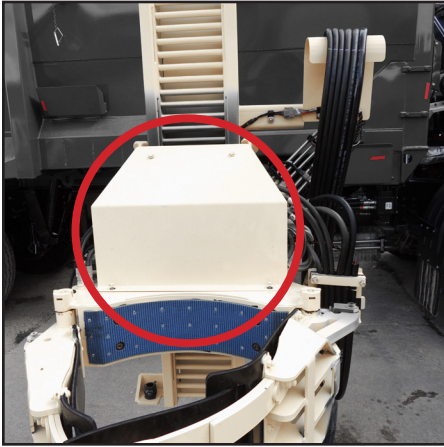

*Figure 1
Remove the grabber cover.*

3. Remove and discard the zip ties that secure the electrical harness to the pipes.
4. Disconnect the electrical harness and remove the pins from the connector (Figure 2).

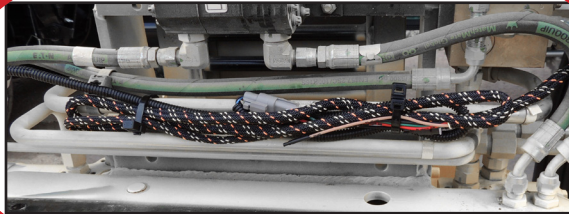
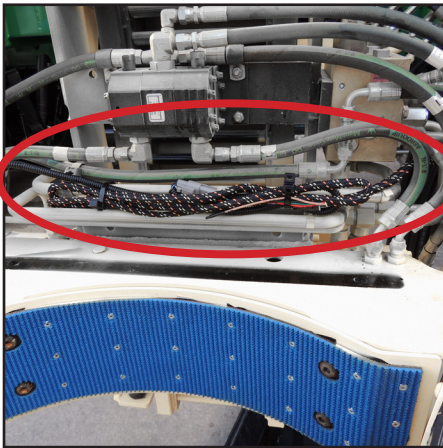

*Figure 2
Disconnect and remove the electrical harness from the grabber.*

This bulletin is limited to Waste Management Use Only.

5. Remove the harness from the arm hose guide bracket by removing the clamps that hold the harness to the bracket (Figure 3). By doing this, the arm hose guide bracket can also be removed. Retain the bracket, clamps, and nuts.

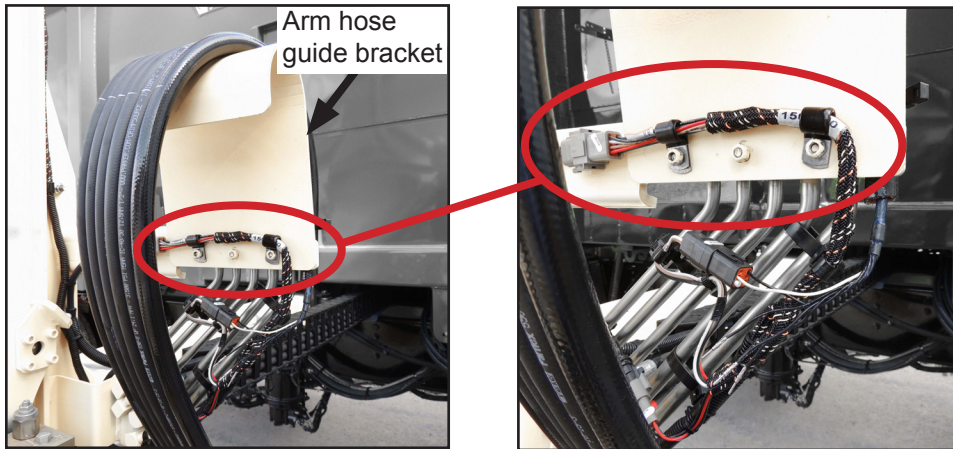

Figure 3

Remove the harness and clamps from the arm hose guide bracket.

6. Disconnect the electrical harness and remove the pins from the connector.
7. Remove the grabber electrical harness from the hose assembly and set aside (Figure 4).



Figure 4

Remove the electrical harness from the hose assembly.

8. At the upper portion of the hose assembly, disconnect all five hoses from their fittings using a 1" wrench and an 11/16" wrench (Figure 5).

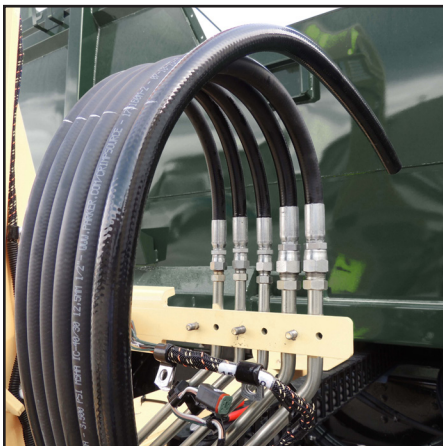

Figure 5

Disconnect the hoses from the upper portion of the hose assembly.

This bulletin is limited to Waste Management Use Only.

9. Set the hoses in an oil collection container to drain any excess hydraulic oil in the hoses.
10. Cycle the grabber fingers a couple of times by hand to remove hydraulic oil from the hoses.
11. At the lower portion of the hose assembly (next to the grabber), use a 9/16" socket wrench to remove and retain the hose clamps, nuts, and washers (Figure 6). Discard the bolts.

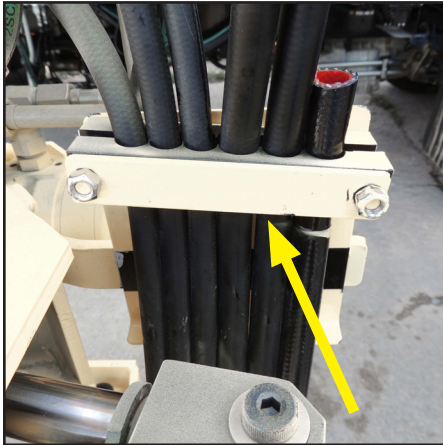

Figure 6

Remove the hose clamp at the bottom of the hose assembly.

12. Disconnect the remaining five hoses on the lower portion of the hose assembly. Hoses are disconnected from their fittings on the manifold and flow divider for grabber cylinder.
13. Remove and discard the plate that held the hose clamps using a 7/32" Allen wrench (Figure 7). Retain the screws.

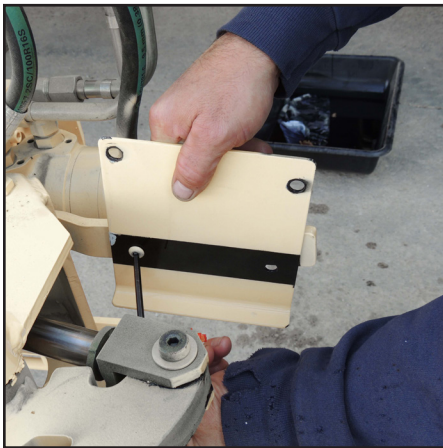

Figure 7

Remove the plate that held the hose clamps (located next to grabber).

This bulletin is limited to Waste Management Use Only.

14. Remove and discard the hydraulic tube clamp bracket (Figure 8 backside of grabber shown). Retain the hardware.

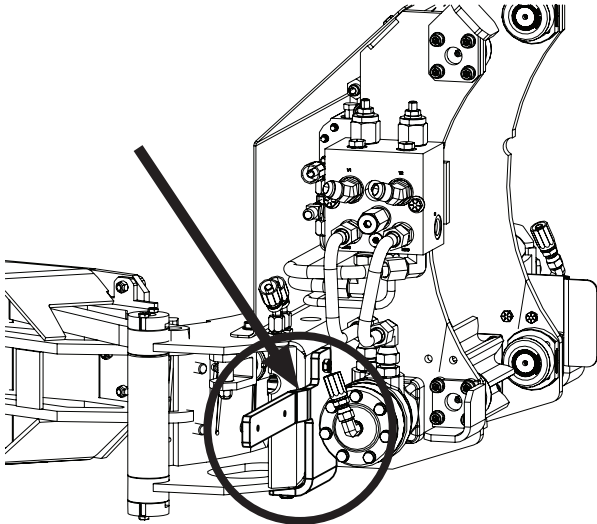

Figure 8
Remove the hydraulic tube clamp plate.

15. Install the new hydraulic tube clamp bracket (P/N 1561880) (the new part is straight; whereas the old part had a manufactured offset bend) using the retained hardware with Loctite (Figure 9). Tighten until tight.

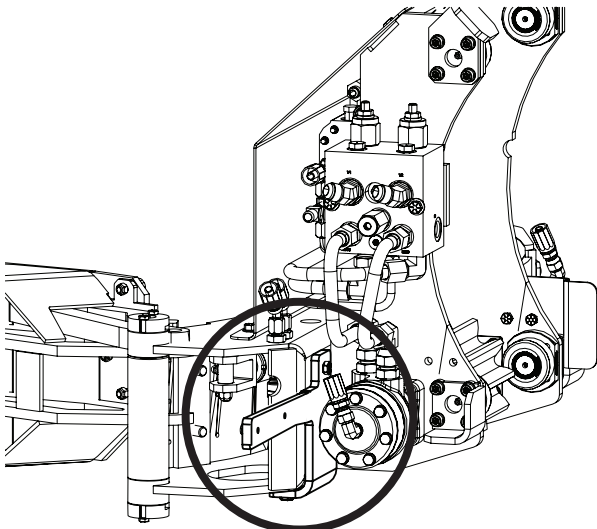

Figure 9
Install the new hydraulic tube clamp plate.

This bulletin is limited to Waste Management Use Only.

16. Install the new hose abrasion control bracket (P/N 1509942) on the mount (to the new hydraulic tube clamp bracket) using the existing screws (with a drop of blue Loctite® added to each screw) (Figure 10). Use a torque wrench to torque to 9 ft-lbs.

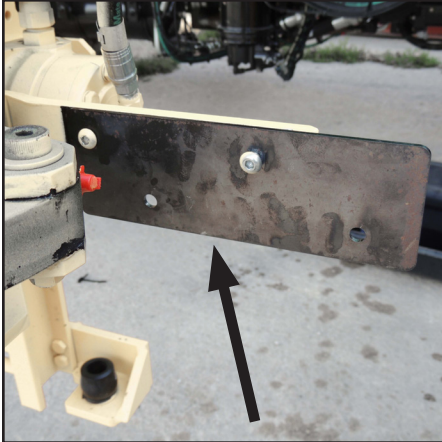

Figure 10

Install the new hose abrasion control bracket to the mount.

17. Install the new nylon hose abrasion control rod (P/N 1509941) on the **backside** of the mount using the new bolts (P/N 1543297) (Figure 11).

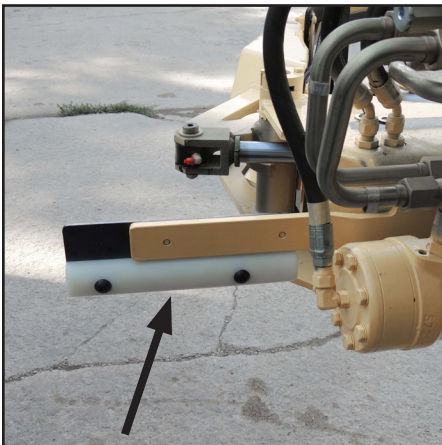

Figure 11

Install the new nylon hose abrasion control rod on the backside of the mount.

18. Remove the two 10-8 fittings on the manifold and replace with the new 10-8 fittings (P/N 1131607) (Figure 12). Tighten until snug.

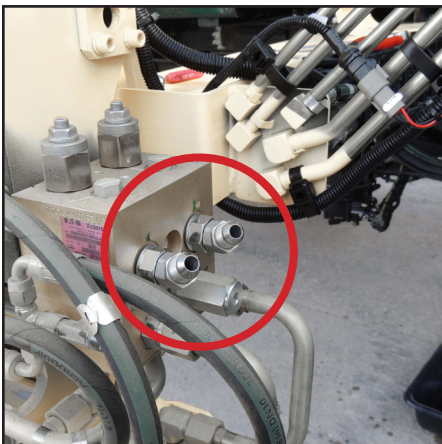

Figure 12

Replace the 10-8 fittings on the manifold with the new 10-8 fittings.

This bulletin is limited to Waste Management Use Only.

19. Open the Velcro® on the new hose sleeve and lay the assembly flat.
20. Thread the grabber electrical harness through the split loom.
21. Thread the grabber electrical harness through the open eyelets (Figure 13 - shown without split loom for clarity of location in sleeve).



Figure 13

Thread the electrical harness through the open eyelets on the hose sleeve.

22. Close the Velcro® on the hose sleeve.
23. Install the hose assembly in place starting at the lower fittings, route the electrical harness on the cab side of hoses. Reconnect the hoses to the proper fittings. Do not twist the hose assembly.

NOTE: Do not tighten the fittings at this step.

NOTE: Use 545 Loctite® thread sealant on the hydraulic fittings.

From the electrical harness working toward the ZR mast:

- #8 hose goes to V2 on the manifold
- #8 hose goes to V1 on the manifold
- #6 hose goes to the tee fitting on the flow control
- #6 hose goes to the flow divider
- #6 hose goes to the #45 fitting on the manifold

24. Install the hose assembly in place at the upper fittings. Reconnect the hoses to the proper fittings (the electrical harness is to the outside when facing the truck and work your way toward the ZR mast). Do not twist the hose assembly.

NOTE: Use 545 Loctite® thread sealant on the hydraulic fittings. On the #8 fittings, use a 1" wrench and 7/8" wrench and using a torque wrench, torque to 42 ft-lbs. On the #6 fittings, use a 11/16" wrench and using a torque wrench, torque to 20 ft-lbs.

25. Use a 1/2" socket wrench to remove the nuts from the stauff clamps on the bracket holding the hoses to the mount (on the upper hoses) (Figure 14). Retain the nuts.

This bulletin is limited to Waste Management Use Only.

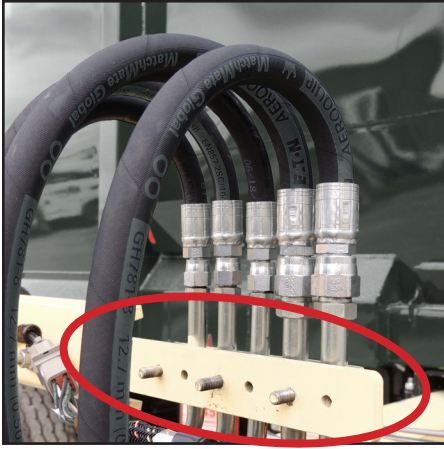

Figure 14

Remove the nuts from the stauff clamps on the upper hose bracket.

26. Install the new hose sleeve by lining up the holes on the sleeve with the bolts where the stauff clamps are (Figure 15). The sleeve goes on the side where the nuts are located.



Figure 15

Install the hose sleeve on the upper hose bracket.

27. Reinstall the arm hose guide bracket under the sleeve to hold the sleeve in place (Figure 16).



Figure 16

Reinstall the arm hose guide bracket under the sleeve.

This bulletin is limited to Waste Management Use Only.

28. Reinstall the arm hose guide bracket to the mount using the retained nuts and 1/2" socket wrench. If the electrical harness is secured to the arm hose guide bracket by clamps, reinstall the harness with clamps and nuts to secure the bracket to the mount (Figure 17). Use a torque wrench to torque to 28 ft-lbs.

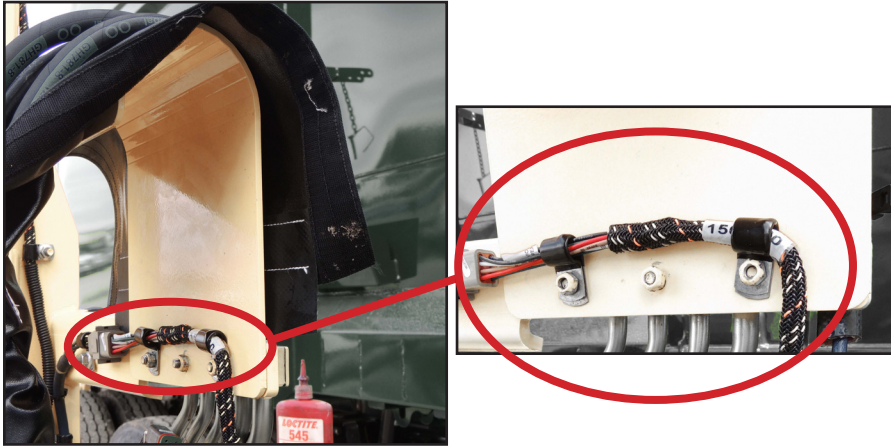

Figure 17

Reinstall the harness and clamps onto the arm hose guide bracket using the retained clamps and nuts.

29. Reconnect the pins on the electrical harness.
30. Reconnect the electrical harness.
31. Zip tie the harness to the bracket or the first hydraulic pipe.
32. Tighten the lower fittings of the hose assembly. Start with the #8 fittings (V1 and V2 on the manifold) and use 13/16" and 7/8" wrenches. Use a torque wrench to torque to 42 ft-lbs.
Use 11/16" wrenches to tighten the #6 fittings. Use a torque wrench to torque to 20 ft-lbs.
33. Reinstall the hose clamps to the new plate at the lower portion of the hose assembly (next to the grabber).
34. Pull the hose sleeve tails up to the hose clamps and, using 9/16" socket wrench, reinstall the existing washers and nuts (Figure 18). Use a torque wrench to torque to 28 ft-lbs.

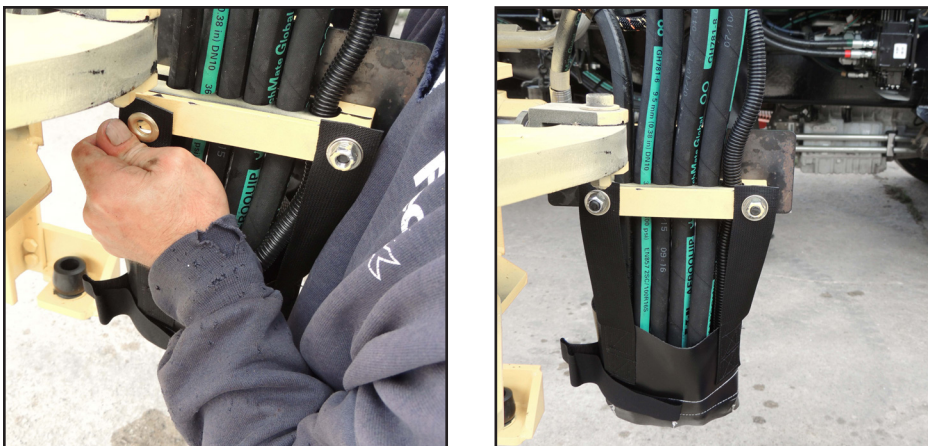

Figure 18

Install the sleeve tails to the hose clamps on the new plate. On right: Finished assembly of the sleeve secured to the hose clamps.

35. Route the grabber electrical harness behind the lower hoses.
36. Reconnect the pins on the electrical harness.
37. Reconnect the electrical harness.

This bulletin is limited to Waste Management Use Only.

38. Zip tie the electrical harness out of the way, such as to the pipes on the grabber (Figure 19).

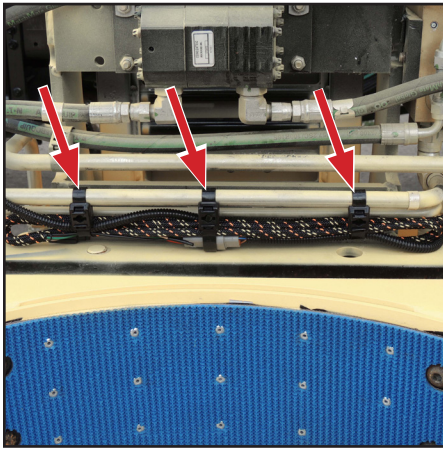

Figure 19

Zip tie the harness to the pipes on the grabber.

39. Remove the conditions of lockout/tagout for testing.
40. Test the functions of the grabber using the joystick.
41. If the grabber does not function as normal, swap the position of the #8 hoses on the manifold.
42. Retest the functions of the grabber using the joystick.
43. Reinstall the grabber cover using the retained hardware.
44. Dispose of any collected oil in accordance with all applicable local, state, or federal regulations.
45. The procedure is complete. Return truck to service.

This bulletin is limited to Waste Management Use Only.

Contact McNeilus For Warranty Claims:

McNeilus should be contacted to submit a warranty claim.

For trucks in service January 1, 2014 to Current, Parts and Labor will be reimbursed.

- Parts Reimbursement - Parts necessary for this update need to be ordered from McNeilus Parts. Claims are to be submitted through the normal warranty claim system. Claims must be received within 30 days of the repair. Claim must include the McNeilus serial number, the customer asset number, and the number of this bulletin.
- Labor Reimbursement - Claims are to be submitted through the normal warranty claim system. Claims must be received within 30 days of the repair. Claim must include the McNeilus serial number, the customer asset number, and the number of this bulletin.

Labor Reimbursement: 2 Hours

For trucks in service January 1, 2012 to December 31, 2013, Parts ONLY will be reimbursed.

- Parts Reimbursement - Parts necessary for this update need to be ordered from McNeilus Parts. Claims are to be submitted through the normal warranty claim system. Claims must be received within 30 days of the repair. Claim must include the McNeilus serial number, the customer asset number, and the number of this bulletin.

Deadline:

If required, this service update should be performed at the earliest opportunity. The following terms must be met to qualify for reimbursement cost.

- For reimbursement, a warranty claim form with proof of installation must be submitted by: **November 8, 2017**

Continuous Improvement:

The change included in this bulletin is part of the McNeilus® Continuous Improvement Process.

McNeilus® Company's quality policy is Providing Customer Satisfaction through Innovative Products, Dedicated Service, and a constant focus on Continuous Improvement.

"The Customer is our Boss!"



(888) 686-7278

www.streetsmartparts.com