

### Meridian FEL Hydraulic Pump CV Drive Shaft Replacement Procedure

**Update Date:** April 11, 2017  
**Bulletin Name:** FEL-TSB-032-A  
**Models:** Meridian Front Loader 78  
**Units Affected:** In-service dates of 1/1/2016 - 1/31/2017

#### Purpose:

McNeilus Truck and Manufacturing requires the Meridian Front Loader hydraulic pump CV drive shaft be replaced because the shafts may be too short and are suspect to disengaging. The hydraulic pump CV drive shaft can break or twist. A hydraulic pump CV drive shaft failure will affect hydraulic pump operation which controls refuse body functions and does not affect chassis driving functions. You must inspect the hydraulic pump CV drive shaft, even if you have recently replaced it.

#### Notice:

- This bulletin should be read and understood in its entirety before performing this update procedure.
- All procedures outlined in the bulletin must be performed by skilled service personnel. Refer to the product service manual for descriptions of maintenance procedures.

#### SAFETY NOTICE

Perform your company's Lockout/Tagout procedure. If your company does not have a Lockout/Tagout procedure, follow OSHA 1910.147 and 1910.146 Confined Space as appropriate.

#### SAFETY NOTICE

Use appropriate Personal Protective Equipment (PPE) as required by your company.

#### Tools and Equipment Required (Customer to supply own):

- Tape measure
- Torque wrench
- Ratchet extension
- Wrenches (see procedure for varying sizes)
- Machinist's marker
- Loctite® 263

## Procedure 1: Safety Set-Up

1. Place unit on a flat surface, block truck tires, and observe all conditions of the Safety Notice concerning Lockout/Tagout posted in this bulletin.
2. Battery Disconnect Switch

If your vehicle is equipped with a battery disconnect switch, it is located near the battery box. Use the battery disconnect switch when performing any maintenance so the vehicle cannot accidentally be started.

1. Turn the battery disconnect switch (Figure 1, Item 1) counterclockwise so the hole on the switch aligns with the hole in the bracket (Figure 1, Item 2).
2. Install the safety lockout device ring (Figure 2, Item 1) through the holes on the battery disconnect switch and the bracket.
3. Install a padlock (Figure 2, Item 2) onto the safety lockout device ring, lock it, and put the key in your pocket. If more than one person is working on the vehicle, each person must install his or her own padlock.

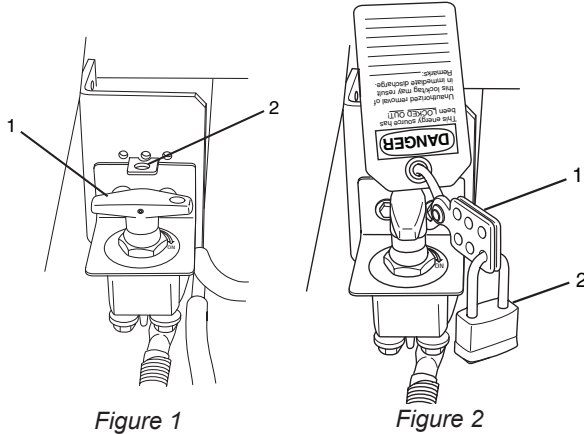

### Battery Cable Disconnect

If your vehicle is not equipped with a battery disconnect switch, disconnect the negative (black) battery cable first, then disconnect the positive (red) cable.

<b>⚠ WARNING</b>	
<b>For trucks without a battery disconnect switch, to prevent accidental vehicle start-up, which could cause death or serious injury, disconnect battery cables (negative cable first) before proceeding.</b>	
<b>Disconnect negative (-) battery cable first. If positive (+) cable should contact ground with negative (-) cable connected, the resulting sparks can cause a battery explosion, which could result in death or serious injury.</b>	

## Procedure 2: Inspect the Hydraulic Pump CV Shaft

1. The hydraulic pump CV shaft is in good working condition and does not need to be replaced if all of the following four conditions are met,
  - a. If the hydraulic pump CV shaft does not show damage.
  - b. If the pump mount shaft side is torqued correctly at 35 ft.-lbs. per bolt.
  - c. If there is 1/8" gap between the pump and CV shaft (Figure 3).

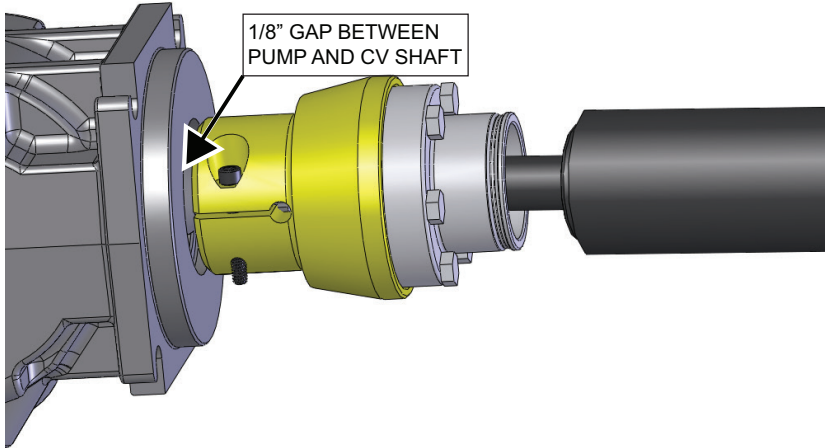

Figure 3

- d. If the hydraulic pump CV shaft has approximately 1" of movement when gripped and moved back and forth.
  - Use a machinist's marker to mark a location on the shaft near the cover (location not critical) (Figure 4).

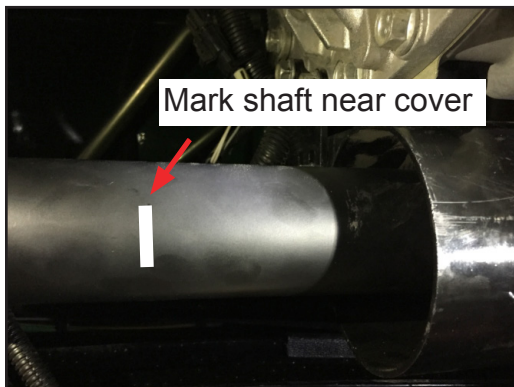

Figure 4

- Using your hand, move the shaft in one direction and check that it moves 3/8" to 1/2" from the mark (Figure 5). Repeat in the other direction. **NOTE:** Shaft should move back and forth a total of 3/4" to 1".

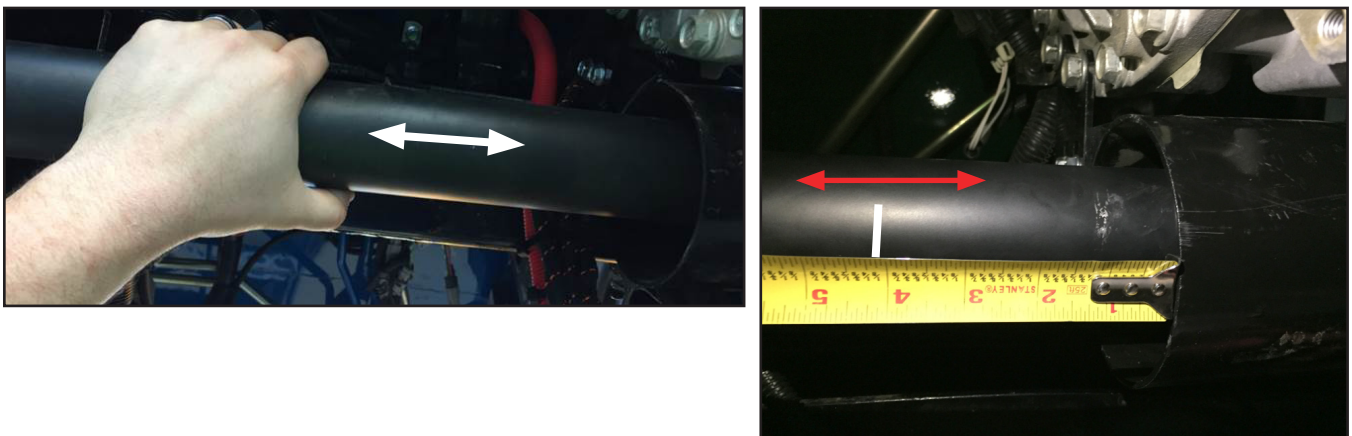

Figure 5

- If the conditions are met, this bulletin is complete. Remove your company's Lockout/Tagout per your company's procedure. If your company does not have a Lockout/Tagout procedure, follow OSHA 1910.147 and 1910.146 Confined Space as appropriate. Return truck to service.
2. If the hydraulic pump CV shaft is damaged, is not torqued correctly, has more or less than 1/8" gap between pump and CV shaft, or moves more or less than 3/4" to 1" back and forth, the hydraulic pump CV shaft must be replaced. Follow the remainder of this bulletin for instructions to measure the shaft length and install a new shaft.

### Procedure 3: Determine Length of the Hydraulic Pump CV Drive Shaft

To determine the required length of the new hydraulic pump CV drive shaft, measure the length of the area the hydraulic pump CV shaft occupies on the truck.

1. Remove and retain the hardware (Figure 6, Item 1) from the square Pump Mount cover (Figure 6, Item 2).

**NOTE:** Do not remove the circular cover.

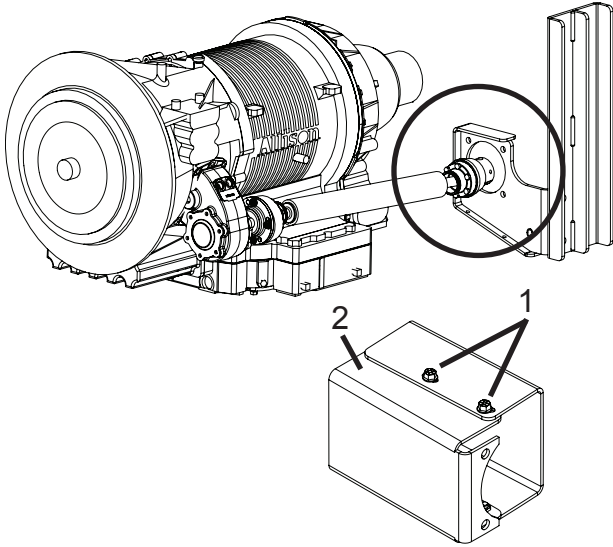

Figure 6

2. Use a tape measure to measure from the PTO flange to the front face of the pump on the vehicle (Figure 7 shown with the CV shaft removed for illustrative purposes only. There is no need to remove the CV shaft to obtain the measurement).
3. Subtract 1/8" from the measurement. (This is to account for the gap between the pump and hydraulic pump CV drive shaft.)
  - Write down this measurement to order a new hydraulic pump CV drive shaft from McNeilus Parts.

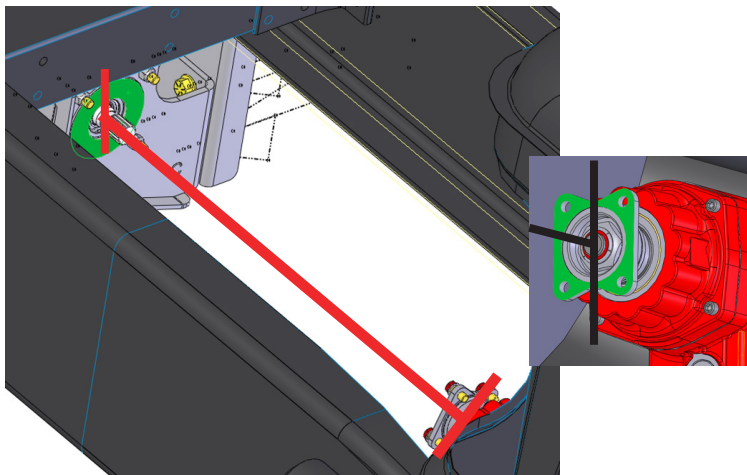

Figure 7

- Reinstall the square pump mount cover (Figure 8, Item 5) with the retained hardware (Figure 8, Item 6). Use a torque wrench to torque the hardware to 28 ft-lbs.

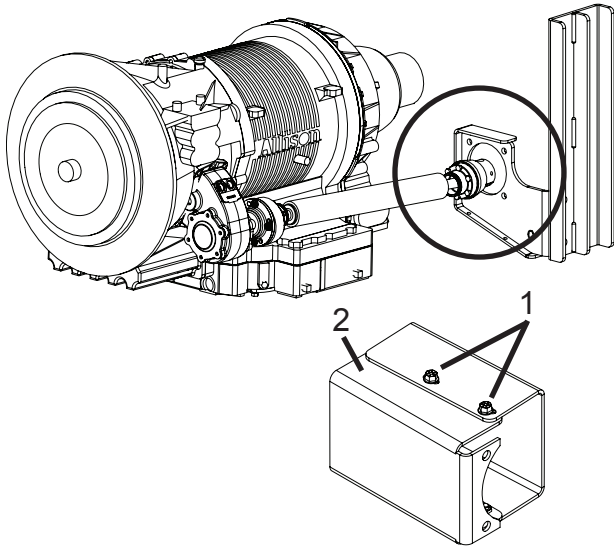

Figure 8

- Order the require parts and the **new Hydraulic Pump CV Shaft** that is listed on the Part Number List according to the length needed. See all required parts and part number list below.

**NOTE:** Shaft lengths are in increments of 1". Round measurement numbers as follows:

For numbers .000" to .499" round DOWN.

For numbers .500" to .999" round UP.

### **Parts Required per Truck:**

Purchase the following parts from McNeilus Truck and Manufacturing, Inc. by calling 888-686-7278.

#### **Hydraulic Pump CV Shaft Lengths and Part Numbers**

Length	Part Number
24	1562473
25	1550456
29	1488014
30	1484576
31	1488017
32	1484577
34	1488021
35	1484578
36	1488022
37	1547495
38	1552189
39	1552191
40	1560608
41	1558837

Item	Part Number	Description	Qty.
1	Varies - See Part Number Listed	Hydraulic Pump CV Drive Shaft (assembly contains hardware items 2 through 4)	1
2	—————	6MM ALLEN HEAD BOLT*	2
3	1140169	SCR, CAP, HEX .38-24X1.00 G8 ZY	4
4	0120302	WASH, LK, IN .38X.69X.04 ZC	4

\*The (2) 6mm Allen head bolts will come with the hydraulic pump CV drive shaft as part of the flange assembly.

**NOTE:** The flange on the PTO side will come attached to the hydraulic pump CV drive shaft; however, the flange on the Pump side will come detached for ease of installation. The six bolts to attach the flange to the CV shaft will be included separately.

#### **PROCEDURE 4: Replace Hydraulic Pump CV Drive Shaft**

Once you receive the new hydraulic pump CV drive shaft, follow these steps to remove the old drive shaft and install the new drive shaft.

#### **Tools and Equipment Required per Truck:**

- Torque wrench
- Ratchet extension
- Wrenches (see procedure for varying sizes)
- Machinist's marker
- Loctite® 263

#### ***Remove Existing Hydraulic Pump CV Drive Shaft***

1. Refer to Procedure 1 on Page 2 for Safety Setup and Lockout/Tagout.
2. Remove and retain the hardware using the appropriate wrenches (Figure 9, Items 3 and 4) from the support plate (Figure 9, Item 2) to disconnect the circular Pump Mount cover (Figure 9, Item 1) from the support plate.
  - **NOTE:** Item 2 is the support plate that is attached to the transmission. The circular cover attaches to the support plate. The plate is shown detached from the transmission for illustrative purposes only. Do not detach the plate from the transmission.
3. Remove and retain the hardware (located on topside and bottom side of the cover) (Figure 9, Item 7) from the square Pump Mount cover (Figure 9, Items 5 and 6).
4. Remove and retain the hardware connecting the square pump mount cover to the pump (hardware not shown, but location shown in Figure 9, Item 8).
5. Remove and retain both halves of the square pump mount cover (Figure 9, Items 5 and 6).

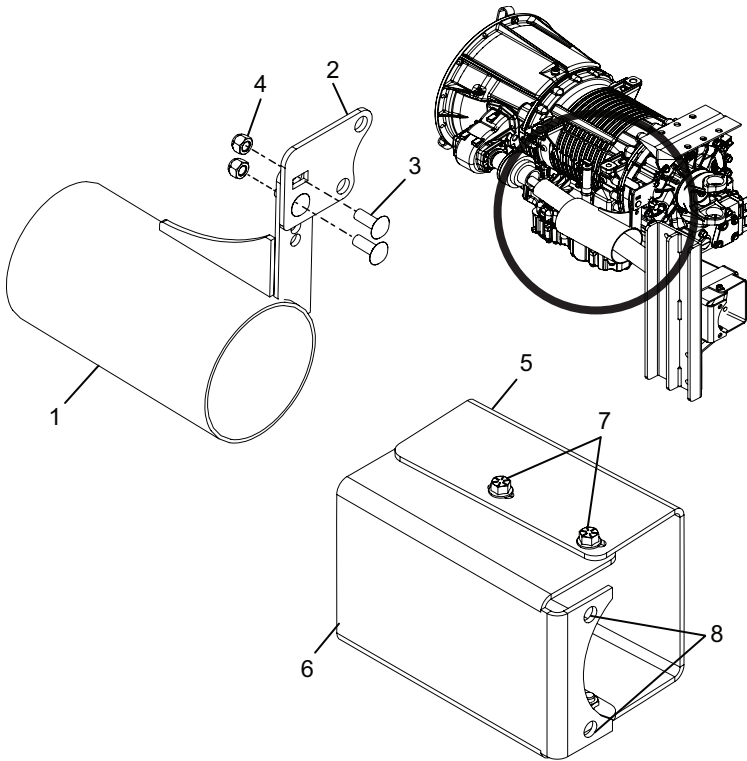

Figure 9

6. Remove the hydraulic pump CV drive shaft from the vehicle using the appropriate tools. Discard hydraulic pump CV drive shaft.

**Install New Hydraulic Pump CV Drive Shaft**

1. Slide the circular Pump Mount cover onto the new hydraulic pump CV drive shaft the same way it was originally.
2. Starting on the PTO connection side, apply Loctite 263 to the new four (4) bolts (P/N 1140169).
3. Use the bolts and new four (4) lock washers (P/N 0120302) to install the CV shaft to the PTO (Figure 10).
4. Use a torque wrench to torque each bolt to 37 ft.-lbs. (Figure 10).

To PTO

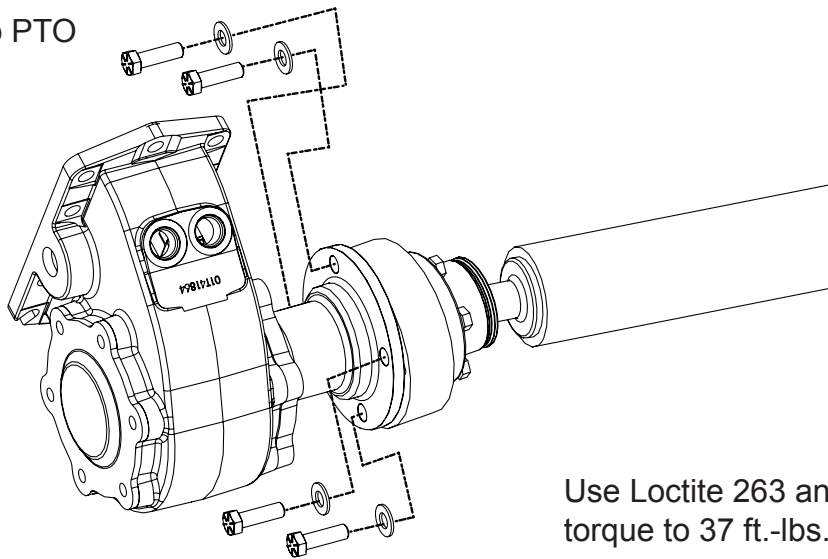

Figure 10

5. Apply Loctite 263 to the new two (2) 6mm Allen head bolts.
6. Install the CV shaft adapter flange into the pump spline until there is a 1/8" gap between the pump and flange (Figure 11).
7. Tighten the bolts, but do not torque at this step.

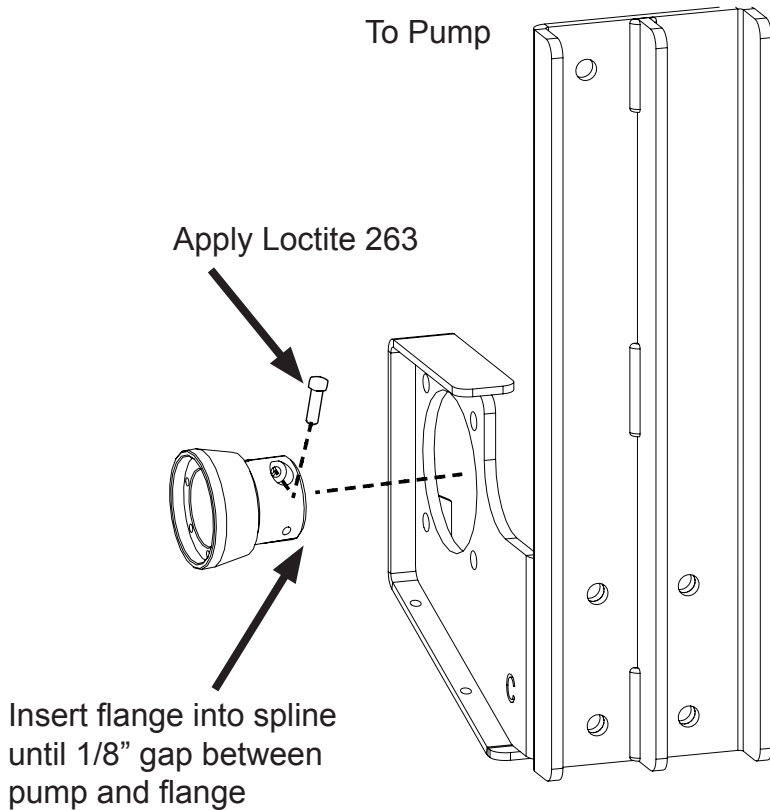

Figure 11

8. Apply Loctite 263 to the new six (6) bolts.
9. Use these bolts to attach the Pump Mount adapter flange to the new CV shaft (Figure 12).
10. Use a torque wrench to torque each bolt to 30 ft.-lbs.

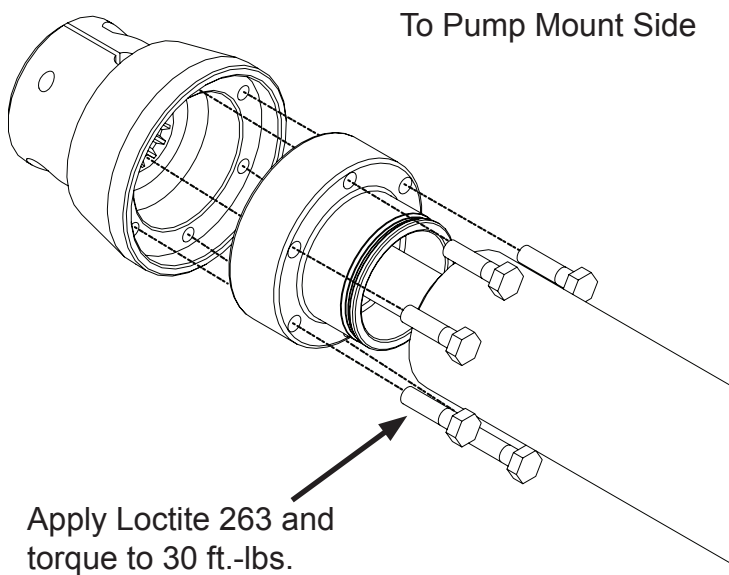

Figure 12

11. Use a torque wrench to torque each 6 mm Allen head bolt to 35 ft.-lbs. on the flange.

12. Using the appropriate wrenches, reinstall the retained hardware (see Figure 13, Items 3 and 4) to attach the circular Pump Mount cover (Figure 13, Item 1) to the support plate (Figure 13, Item 2). Tighten hardware until tight.

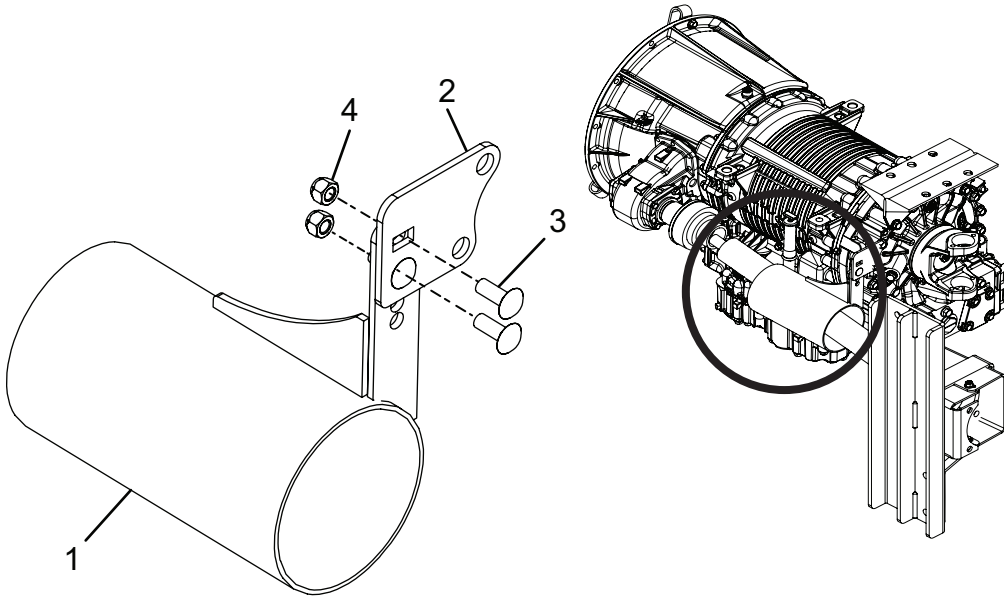

Figure 13

13. Use a machinist's marker to mark a location on the shaft near the cover (location not critical) (Figure 14).

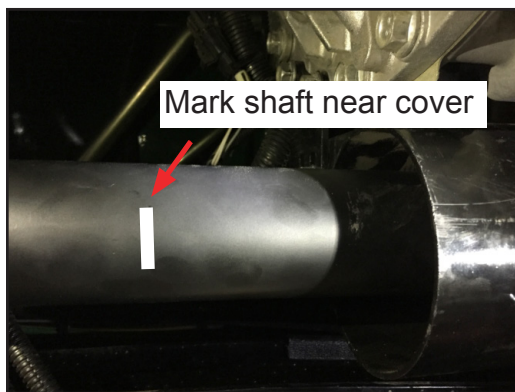

Figure 14

14. Using your hand, move the shaft in one direction and check that it moves  $3/8$ " to  $1/2$ " from the mark (Figure 15). Repeat in the other direction. **NOTE:** Shaft should move back and forth a total of  $3/4$ " to 1".

**IMPORTANT:** If the shaft moves more or less than  $3/4$ " to 1" back and forth, it may be installed incorrectly or the wrong length. Contact a McNeilus National Service Representative at 888-686-7278 for assistance.

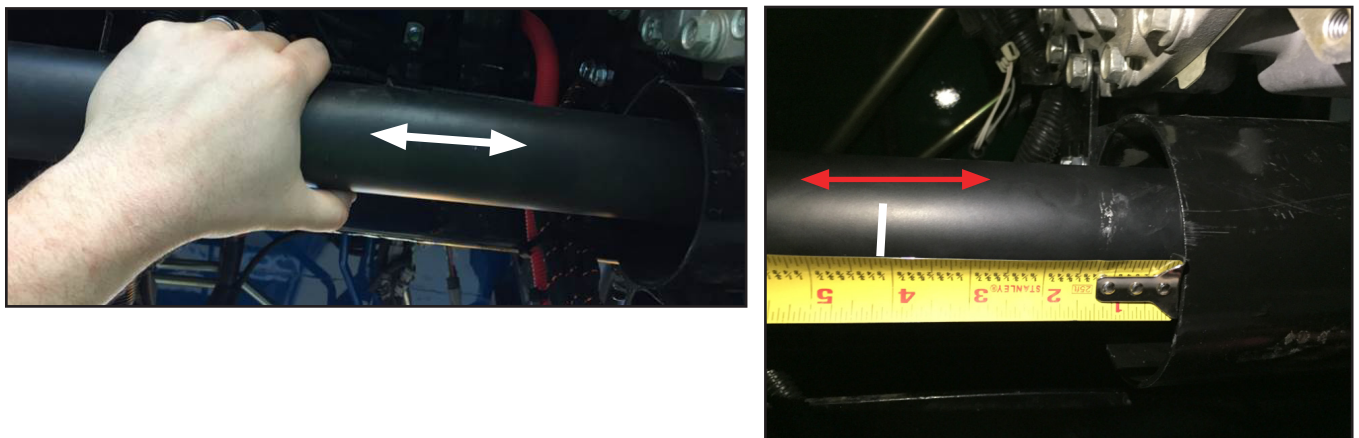

Figure 15

15. Using appropriate wrenches, reinstall the pump mount cover (Figure 16, Item 1) using the retained hardware (Figure 16, Item 2) to the pump mount support plate (Figure 16, Item 3).

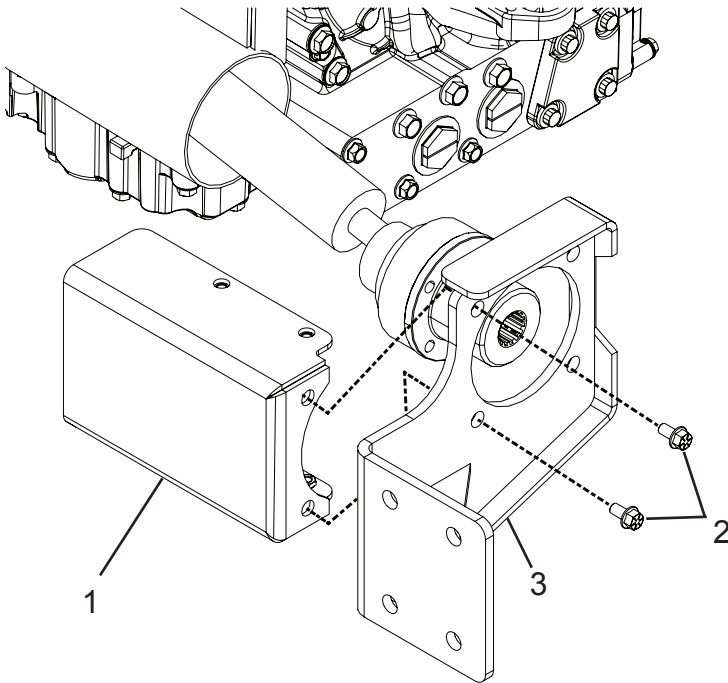

Figure 16

16. Install the existing half of the pump mount cover (Figure 17, Item 1) using the retained hardware (Figure 17, Item 2). Use a torque wrench to torque the hardware to 28 ft.-lbs.

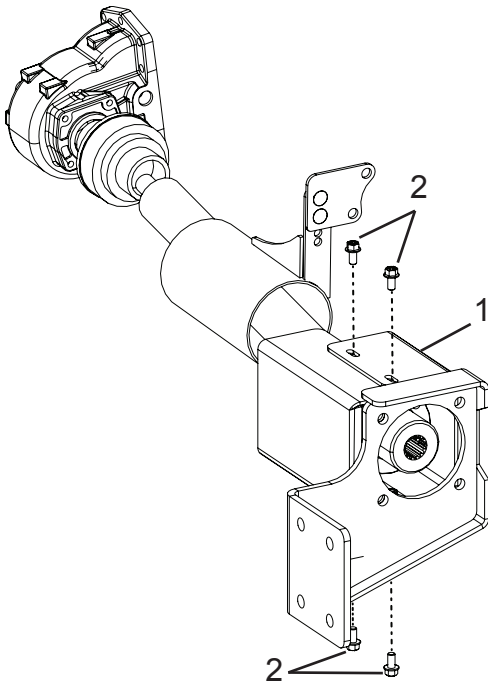

Figure 17

17. Procedure is complete.
18. Remove your company's Lockout/Tagout per your company's procedure. If your company does not have a Lockout/Tagout procedure, follow OSHA 1910.147 and 1910.146 Confined Space as appropriate.

## Reimbursement of Costs:

Upon receipt of the parts, complete the Hydraulic Pump CV Drive Shaft Replacement Procedure for each affected unit. The time of accomplishment may vary due to a number of factors; however, the estimated time for completion of the inspection and measuring procedures is 1 hour under normal circumstances. The estimated time for completion of the new hydraulic pump CV drive shaft installation procedure is 1 hour under normal circumstances. Affected units shall be repaired using the customer's own qualified service technicians.

### Labor Reimbursement:

In order to receive credit if you qualify, claims must be submitted through the normal McNeilus Warranty claim system\*. Claims must be received within 30 days of the repair. Claims must include the McNeilus serial number of the truck, the customer asset number, and the number of this bulletin. NOTE: One claim per truck.

**Labor Reimbursement: 1 Hour for Inspection and Measuring Procedures (Procedures 2 and 3)  
1 Hour for new hydraulic pump CV drive shaft Installation Procedure  
(Procedure 4)**

### Parts Reimbursement:

Parts and ground shipping will be reimbursed to the customer. Parts necessary for this repair must be ordered from McNeilus Parts at 888-686-7278.

Claims must be submitted through the normal McNeilus Warranty claim system. Claims must be received within 30 days of the repair. Claims must include the McNeilus serial number of the truck, the customer asset number, and this bulletin's number. NOTE: One claim per truck.

### Deadline:

If required, this service update should be performed at the earliest opportunity. The following terms must be met to qualify for reimbursement cost.

- For reimbursement, a warranty claim form with proof of installation must be submitted by: **August 17, 2017**
- \* File a labor reimbursement claim for the 1 hour of inspection and measuring procedures after the inspection and measuring procedures are completed. If it is necessary to replace the hydraulic pump CV drive shaft, file a labor reimbursement claim for the 1 hour of installation procedure after the procedure is completed.

### Contact:

If you have questions or need further information, please contact a McNeilus National Service Representative at 888-686-7278.

## Continuous Improvement:

The change included in this bulletin is part of the McNeilus® Continuous Improvement Process.

*McNeilus® Company's quality policy is Providing Customer Satisfaction through Innovative Products, Dedicated Service, and a constant focus on Continuous Improvement.*

***"The Customer is our Boss!"***



**(888) 686-7278**

**www.streetsmartparts.com**