

REFERENCE:	Nova Bus Manuals
SECTION:	19: Fire suppression system
RS N°:	MQR 7621-919
EFFECTIVE IN PROD.:	N/A

APPLICATION DEADLINE: 2019FE28
CLAIM REFERENCE NUMBER: WB-3876

SUBJECT:	Engine compartment ventilation
JUSTIFICATION:	Engine compartment may have high temperature issues due to inadequate heat dissipation.

LEVEL	DESCRIPTION	DIRECT CHARGES		TIME
		LABOUR	MATERIAL	
1	Install a ventilation fan in the engine compartment, reprogram the V-BEA system.	Customer	Nova Bus	6.5 h
2	–	–	–	–

DISPOSAL OF PARTS

REMOVED PARTS ARE:	DISCARDED *	RETAINED	* Dispose of the unused parts and the defective parts in accordance with local environmental standards in effect.
	Yes	–	

REVISION HISTORY

REV.	DATE	CHANGE DESCRIPTION	WRITTEN BY
NR	2017SE08	Initial release	Kumaraswamy K S

MATERIAL

QTY	PART N°	REV.	DESCRIPTION	REPLACES PART N°
LEVEL 1				
1	2394308	B	BRACKET CLIP	--
2	4668145	A	RUBBER STOPPER	--
1	N11690-30	--	CIRCUIT BREAKER 30A GREEN	--
5	N16646	--	WASHER FLAT M6 SS DIN125A	--
5	N17565	--	WASHER OVERSIZE M6 SS DIN9021	--
6	N17882	--	BOLT M6X25 SS GR.A2 DIN933	--
6	N20216	--	WASHER OVERSIZE M5 SS DIN9021	--
4	N24104	--	BOLT HEX	--
4	N24407	--	LOCKNYL M6 SS GR A2 DIN 985	--
6	N26262	--	RIVET	--
2	N27714	--	WASHER LOCK SPR M6 SS A4	--
1	N28219	--	WASHER OVERSIZE M8	--
1	N28734-02	--	RESISTOR ASM 1K 2WATT	--
4	N30730	--	SST FLAT WASHER M6 HEAVY DUTY	--
1	N43233	--	NUT HEX M8 FLANGED WITH INSERT	--
1	N43774	--	SCREW M8X25 FL SSA2 C70 D6921	--
6	N44681	--	NUT LOCKNYL M5 SSA4 DIN985	--
1	N44689	--	WASHER LOCKHELI M6 SSA4	--
2	N44881-02	--	SCREW M6X25 FL YP C8.8 D6921	--
1	N44884-01	--	SCREW M6X20 FL SSA2 C70 D6921	--
9	N44890	A	NUT LOCKNYL M6 FL SSA2 C70	--
6	N49087	--	SCREW M5X16 MACH PAN CR SS	--
15	N56339	--	TIE TEFZEL CABLE TIES	--
2	N57040	A	TIE CABLE MOUNT HI-HEAT	--
4	N66013	--	WASHER NORD-LOCK M6 GLUED SS	--
2	N67582	--	BUMPER M6X19X16	--
2	N70449	--	SHIM EPDM BLACK (1/32)DURO 80A	--
4	N71491	--	SCREW M6X35 MACH BUTT ALLEN SS	--
1	565969 (N78869)	--	SENSOR TEMP	--
1	N80438	C	FAN AXIAL W BRUSHLESS DC MOTOR	--
1	N84669	A	BRACKET SENSOR ASSEMBLY	--
1	N87563-01	--	GRILL LOUVER REAR ENG DOOR (BLUE)	--
1	N87578-01	--	DOOR ENGINE PAINT DETAILS (BLUE)	N72058-01
1	N632000532	--	WIRE KIT #2 FAN ENGINE	--
1	N90904	--	DECAL MEDIUM STRIP CTTRANSIT	--
1	N90944	--	DECAL small STRIP CTTRANSIT	--
1	N59566	--	DECAL WARNING RIGHT TURNS	--

QTY	PART N°	REV.	DESCRIPTION	REPLACES PART N°
1	N33325	-	RIVENUT M6 CYLINDRICAL HD	-
1	N34498-03	-	BRACKET STRAIGHT	-
1	N16646	-	WASHER FLAT M6 SS DIN125A	-
1	N44689	-	WASHER LOCKHELI M6 SSA4	-
1	N17882	-	BOLT M6X25 SS GR.A2 DIN933	-
1	N57040	A	TIE CABLE MOUNT HI-HEAT	-
1	N44881-02	-	SCREW M6X25 FL YP C8.8 D6921	-
1	N38593	-	NUT FLANGED WITH INSERT	-
3	G5007995	-	CABLE TIE	-
SHOP SUPPLY				
1	N90484-03	-	TUBING HEATSHRINK DUAL WALL	-
1	N74787	-	TAPE ELEC CLOTH 19 X 0.27 THK	-

Materials will be available within 125 days once your order has been placed. To order, please contact Prevost Parts by phone at 1-800-771-6682, by fax at 1-888-668-2555 or by email at prevostparts.commandes@volvo.com. Specify document number, quantity of parts required and shipping address.

CLIENT	ORDER	ROAD NUMBER		VIN (2NVY/4RKY...)		QTY	PROGRAM	REV
		FROM	TO	FROM	TO			
CT Transit - Connecticut	L815	1426	1429	S92L0E4500709	S92L0E4500712	4	FB_CON6HE__00	J

TO OBTAIN THE SOFTWARE REVISION REQUIRED ("J" OR LATER), CONTACT YOUR AFTER-SALES REPRESENTATIVE

**WARNING**

Follow your internal safety procedures.

**WARNING**

Disconnect the batteries prior to starting any work on the vehicle. See your maintenance manual section 16: *Batteries*.

PROCEDURE

ENGINE FAN INSTALLATION

- 1.1. Turn off power switch in battery compartment. Disconnect the negative battery cable.
- 1.2. Remove and replace the engine door. Transfer all the parts and the hardware from the original door to the new one.

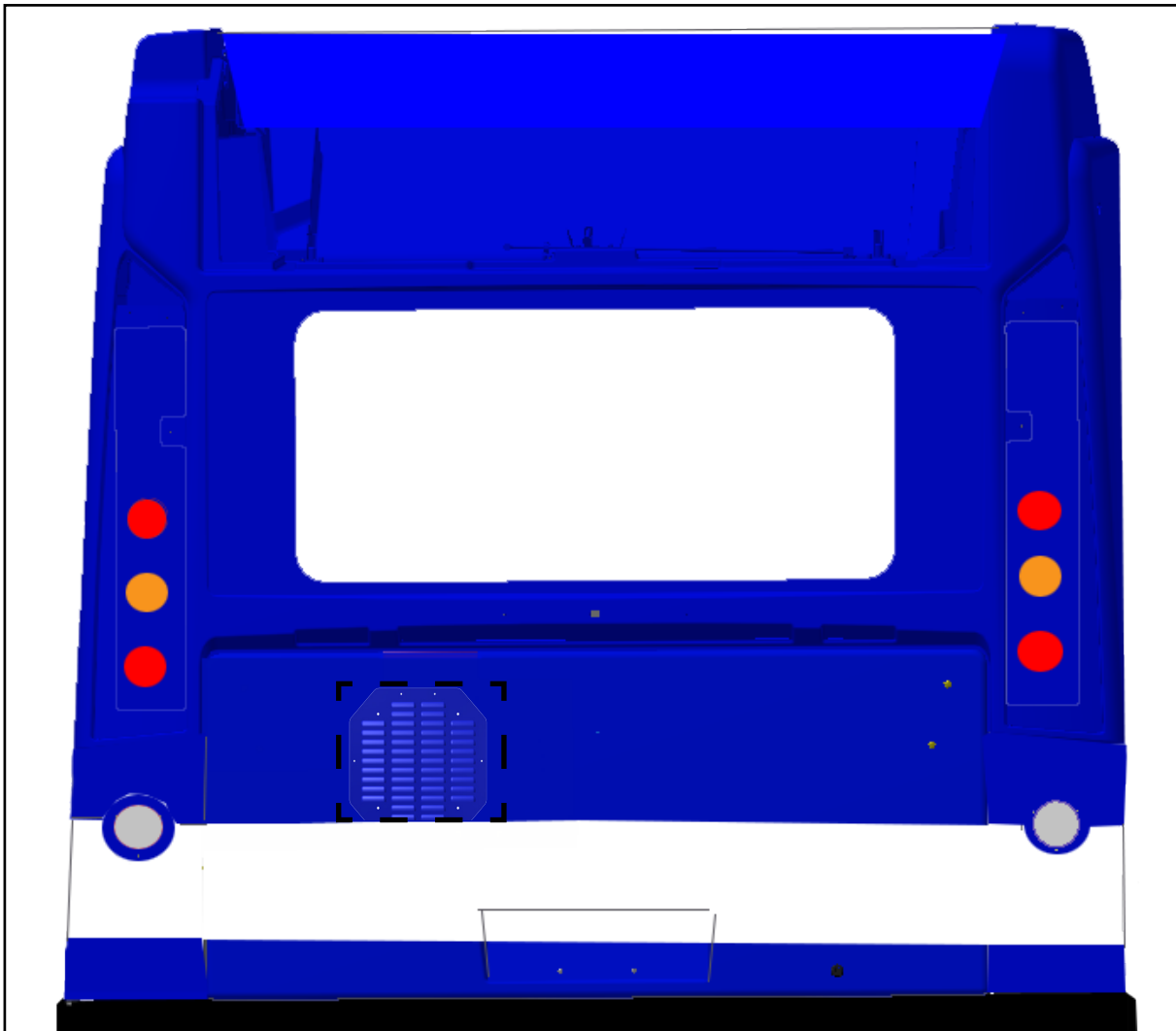

Figure 1 - Install the New Door and the Grill Louver

- 1.3. Prior to installation of decal N90944 (on the grill louver) as well as N90904 and N59566 on the door, all surfaces must be washed and degreased.
- 1.4. Align the decal N90904 with the existing decals on the vehicle.
- 1.5. Install the decal N59566 in the position shown on the engine door (see Figure 2).
- 1.6. Install temporarily the grill louver (opening must be pointing down on the outside) to determine the position of N90944 and install the decal (see figure 2).

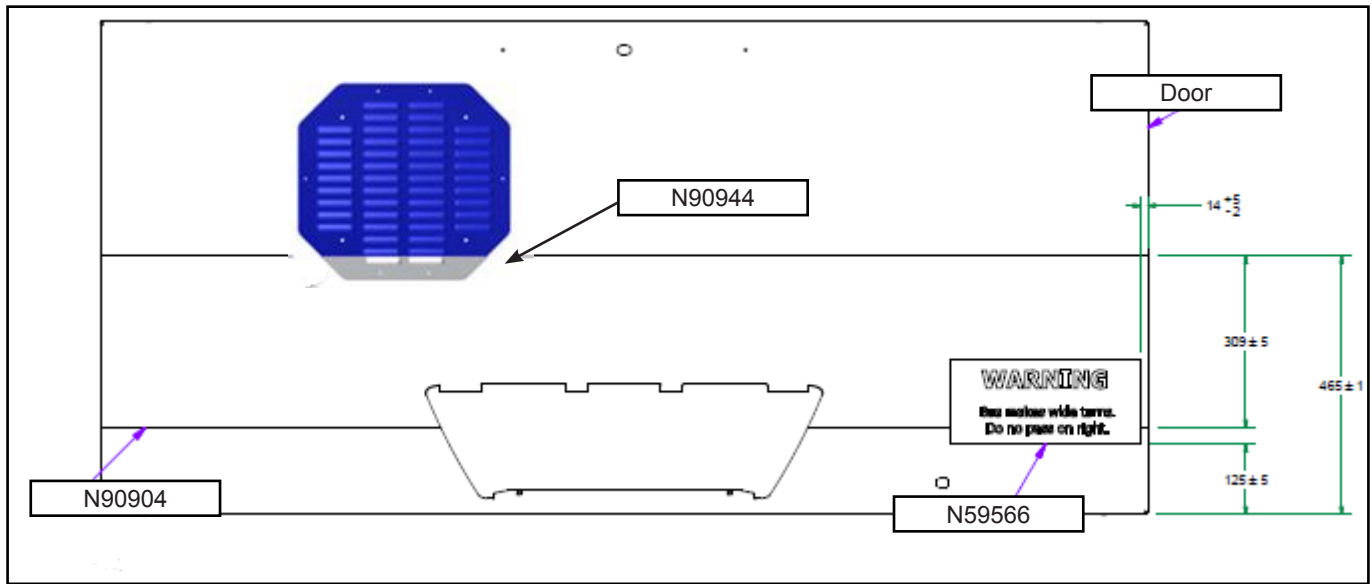

Figure 2 - Installation of Decals on Engine Door

- 1.7. Remove the grill louver and apply a clear coat on the engine door and on the grill louver separately after the installation of decals. Allow time to dry.

- 1.8. Install the grill louver N87563-01 onto the engine door (see Figure 3).
- 1.9. Place the engine fan N80438 on the inside to position the wiring pigtail on the right hand side, towards the center of the engine door. Install the four N71491 bolts, N16646 washers and N44890 nuts using 5/32" hex socket, a 10mm socket wrench and a torque wrench (see Figure 3 and Figure 4).
- 1.10. Torque the nuts to 7.3 lb-ft (10 N•m) and apply torque seal. Install the six rivets in the holes present on the grill louver (see Figure 3 and Figure 4).

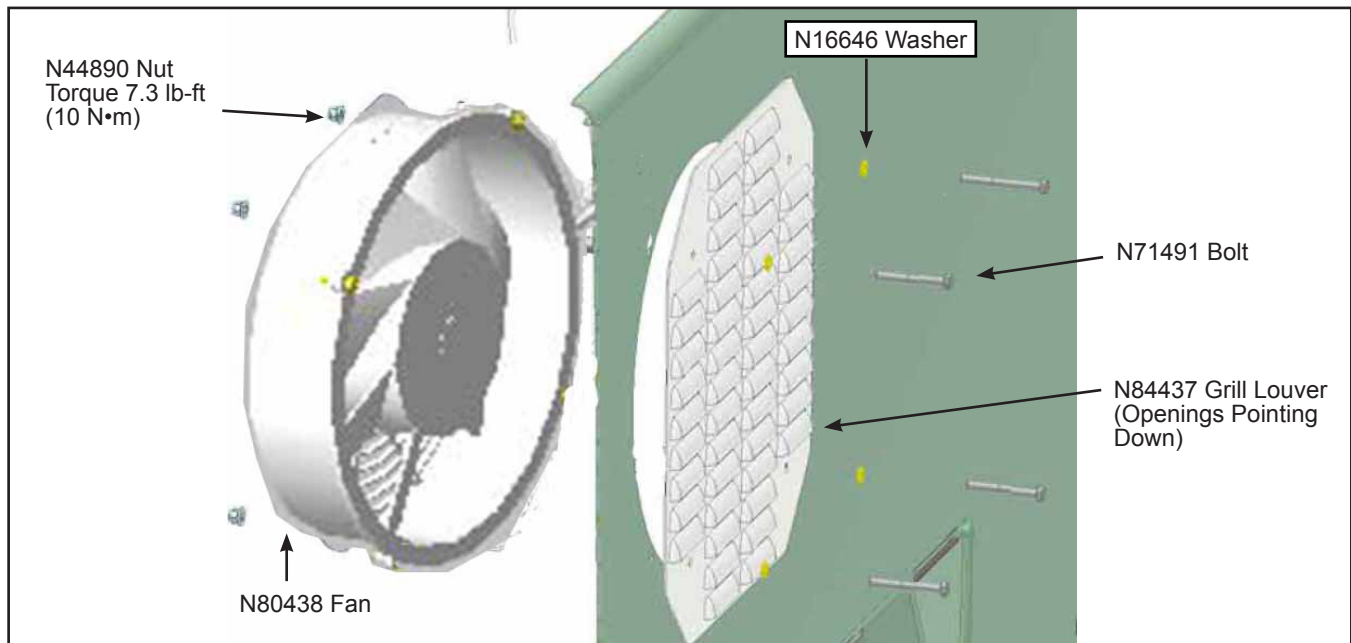

Figure 3 - Install Grill Louver and Electrical Fan

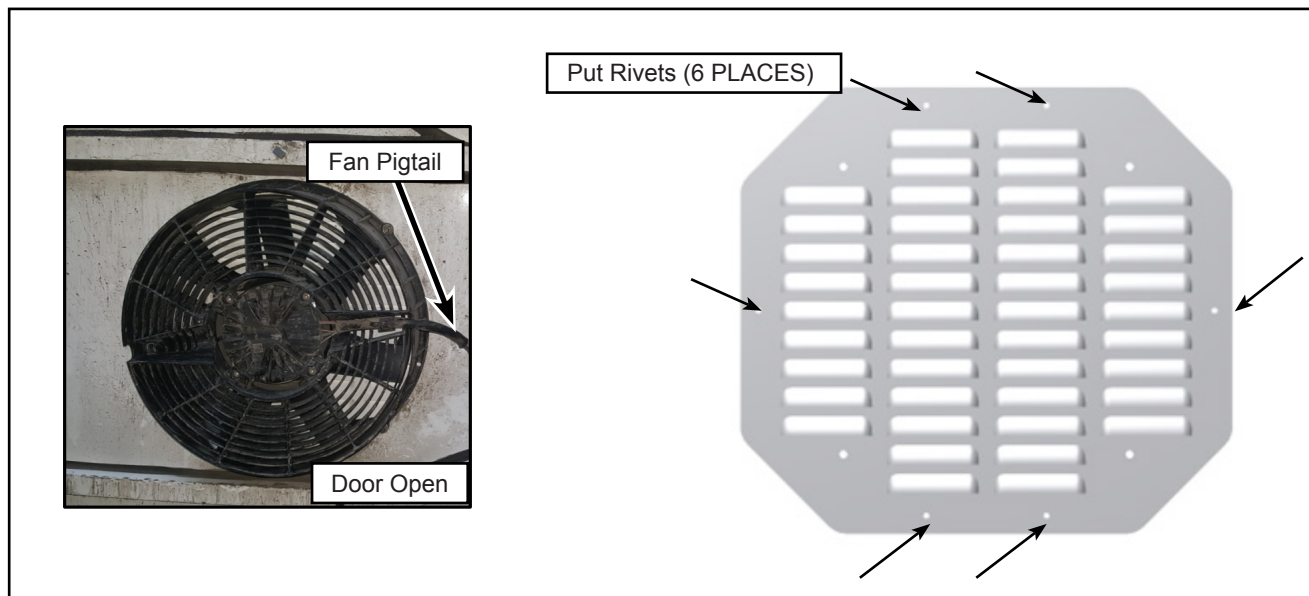

Figure 4 - Install Fan Cable Tie Mount and the Six Grill Louver Rivets

- 1.11. On the door structure, with a ruler or a measuring tape, start from the harness mounting bolt and reach the other side structure beam by going straight.
- 1.12. Mark a drill point directly in the middle of the structure beam. Distance between 2 points must be approx. 195mm (see Figure 5).

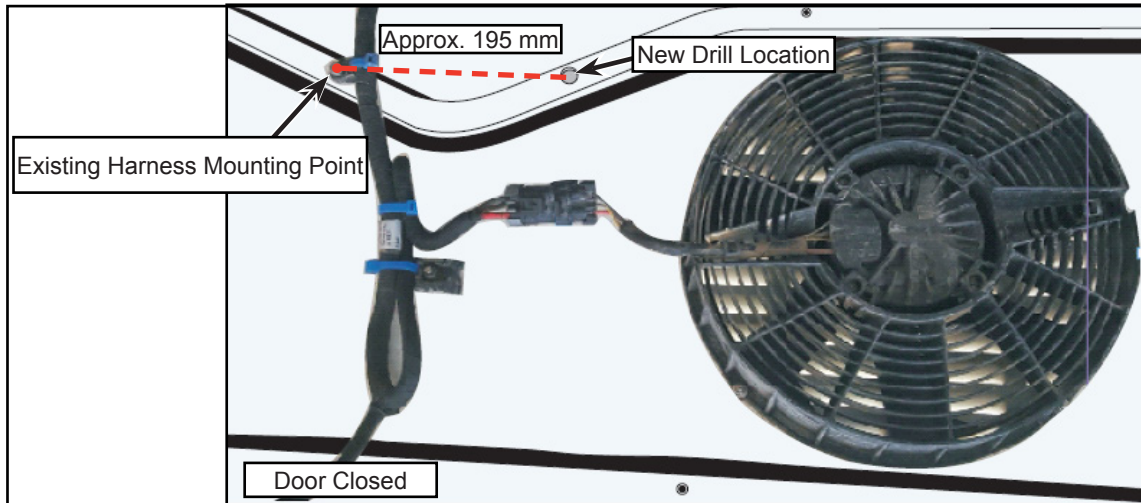

Figure 5 - Typical View of Door Structure

- 1.13. Drill a hole of $(9.1 \pm 0.1 \text{ mm})$, using a 1/4" drill stopper. Use T, 9.1mm or 3/8" drill sizes. Deburr edges of the drilled hole.
- 1.14. Apply corrosion protector to drilled hole and allow it to dry.
- 1.15. Install M6 rivnut N33325 using a rivet gun (see Figure 6).

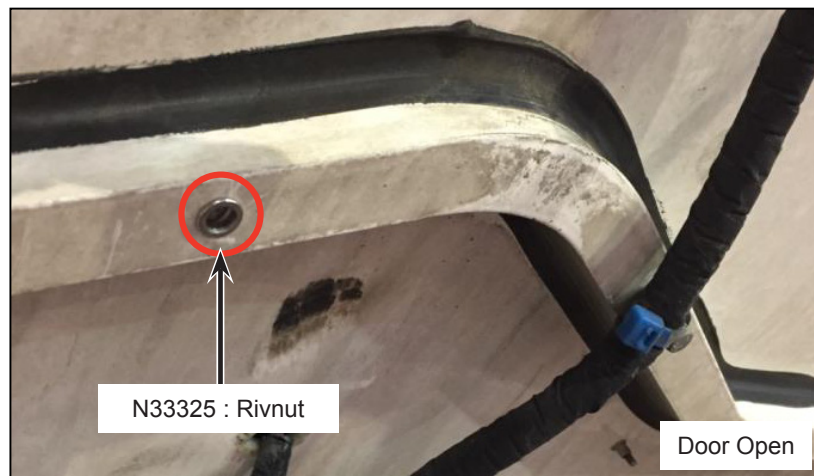

Figure 6 - Installation of Rivnut (N33325) to Door Structure

1.16. Install a bracket N34498-03 with hardware (see Figure 7). Tool: 10mm socket.

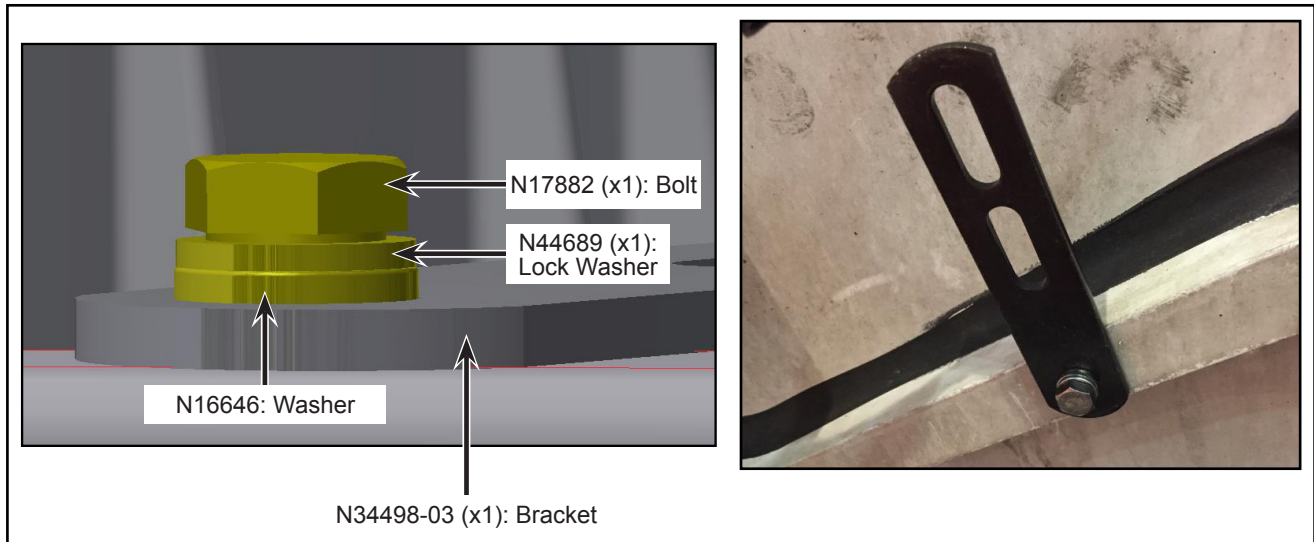

Figure 7 - Typical View of Fan Bracket Installation

1.17. Align the bracket along a vertical axis and torque the bracket bolt to 6.7±0.7 lb-ft (9±1 N•m) (see Figure 8).

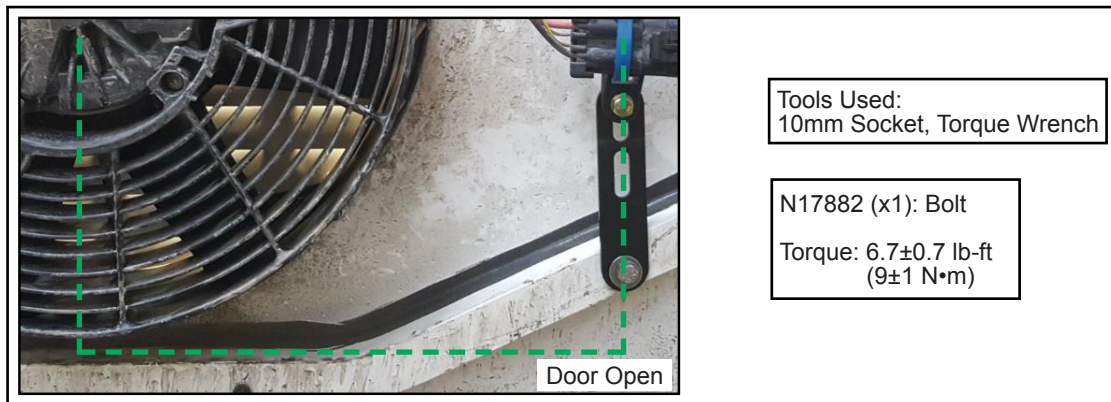

Figure 8 - Typical View of Bracket Orientation

1.18. Apply torque seal (see Figure 9).



Figure 9 - Torque Seal Application

- 1.19. Install a cable mount N57040 on the bracket end with hardware (see Figure 10).
1.20. Tighten the hardware as per torque recommendation (see Figure 10).

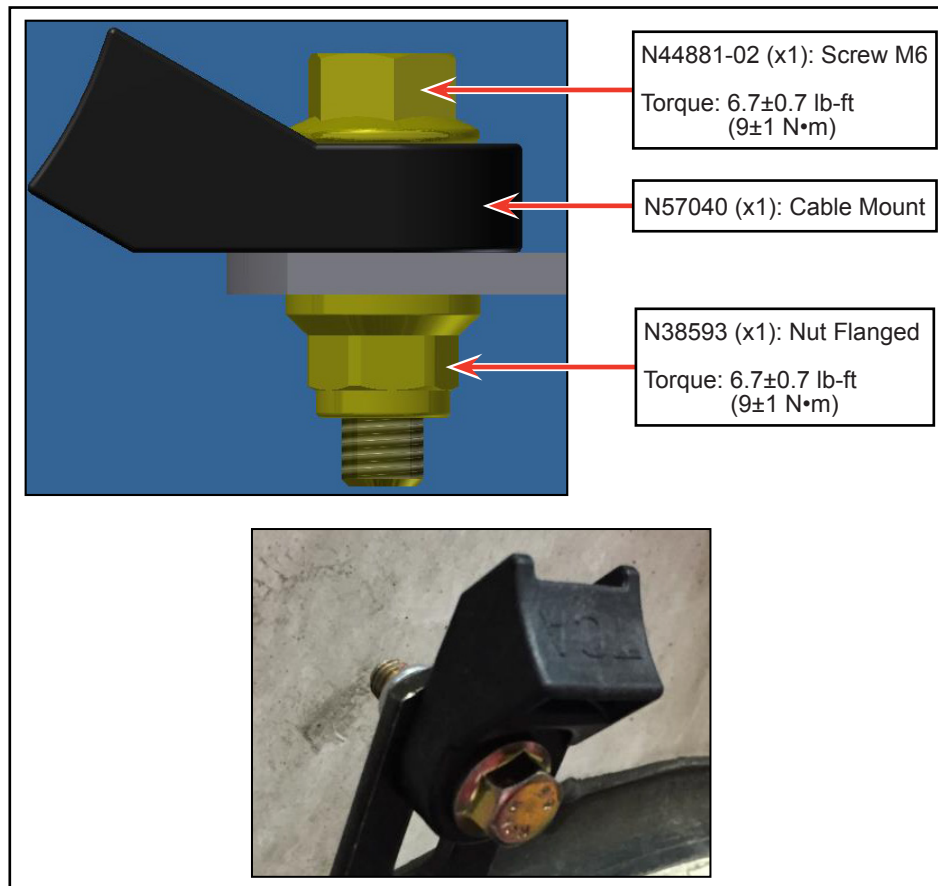

Figure 10 - Cable Mount Installation



NOTE

Tools used to install Cable Mount: 10mm socket, 10mm wrench and torque wrench.



NOTE

While installing cable mount, it is necessary to hold the clamp in place during torquing of hardware in order to prevent rotation.

- 1.21. Apply torque seal.

- 1.22. Cut 2 lengths of heat shrink tube N90484-03 to get a 2.5 inch cut length on each connector side. Cut the heat shrink tube with a massicot, a flat blade scissor/plier/cutter or an X-Acto knife with a metal ruler to be sure to achieve a straight cut.

**CAUTION**

Make sure there is NO notch or dent along the cut, since this might cause the tube to split upon later shrinking it with the heat gun.

- 1.23. Insert on the harness side a 2.5-inch cut length of heat shrink tube. Place the heat shrink tube to cover from the wiring to the end of the connectors and make sure that the tubing does not overlap the loom on any side (see Figure 11).



Figure 11 - Tubing NOT Overlapping the Loom

- 1.24. Move the loom further away if it interferes with the heat shrink tube. Remove the mating seal before heating the shrink to avoid damage.
- 1.25. Shrink the tubing with the heat gun (see Figure 12). Do not overheat since excessive heat could split the tubing and damage the connector.

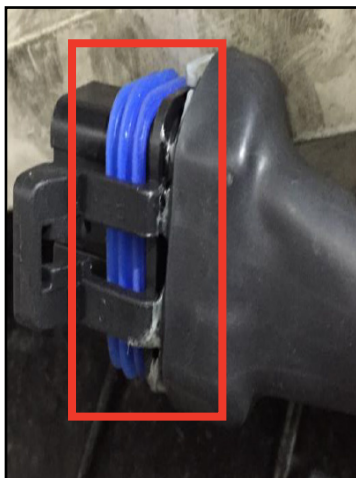

Figure 12 - Tubing Installation

- 1.26. Make sure that the adhesive liner of the heat shrink penetrates between the wires for an optimal protection against the water projections. Reinsert the mating seal.
- 1.27. Apply cloth tape N74787 to protect the wires and smoothly join the cable-side end of the heat shrink tube to the cable loom (see Figure 13).



Figure 13 - Typical Installation of Coroplast Tape (N74787)

- 1.28. Repeat steps 1.30 to 1.34 on the fan-side connector.
- 1.29. Secure the fan connector side on the cable mount with cable tie G5007995 (see Figure 14).



Figure 14 - Cable Tie (G5007995) Installation

1.30. Connect the two connectors side and make sure to form dripping loops on the fan wiring (see Figure 15).



Figure 15 - Connectors Installation

1.31. Install the wiring harness with two cable ties G5007995 (see Figure 16).

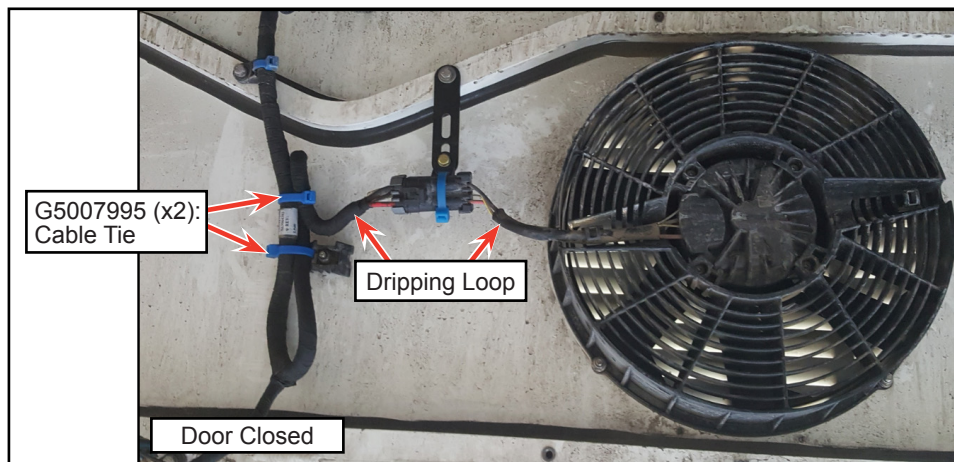

Figure 16 - Cable Tie (G5007995) Installation

- 1.32. Install the tie cable mount N57040 onto the harness bracket 2394308 with an N44881-02 bolt and N44890 nut (see Figure 17).
- 1.33. Use the rear seat hatch to access the engine compartment. Install harness bracket 2394308 with existing hardware (see Figure 17).
- 1.34. Install bracket sensor assembly N84669 over the +MT-X9564A connector bracket.
- 1.35. Install the sensor (see Figure 17).

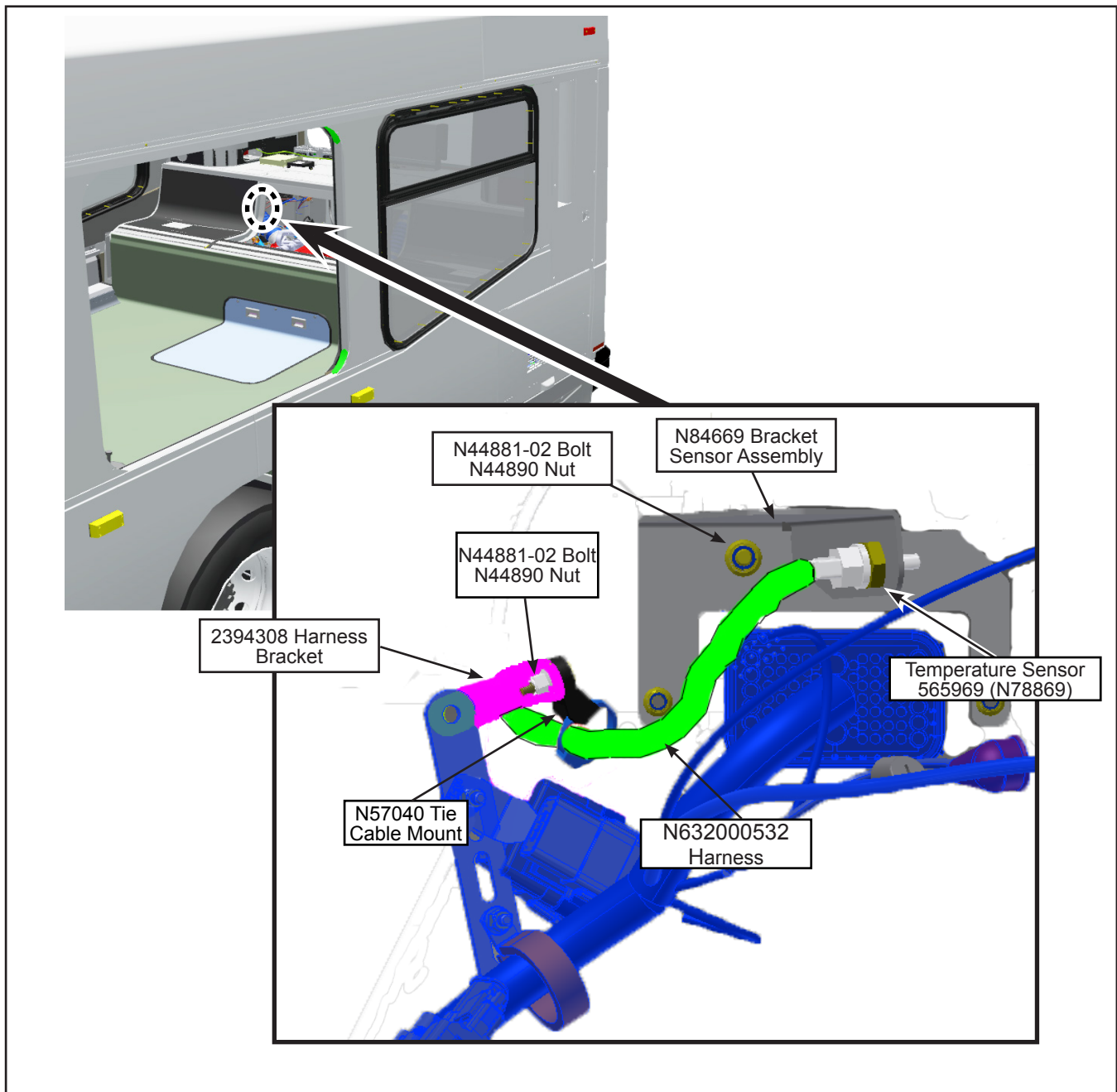

Figure 17 - Install and Connect Temperature Sensor

HARNESS INSTALLATION

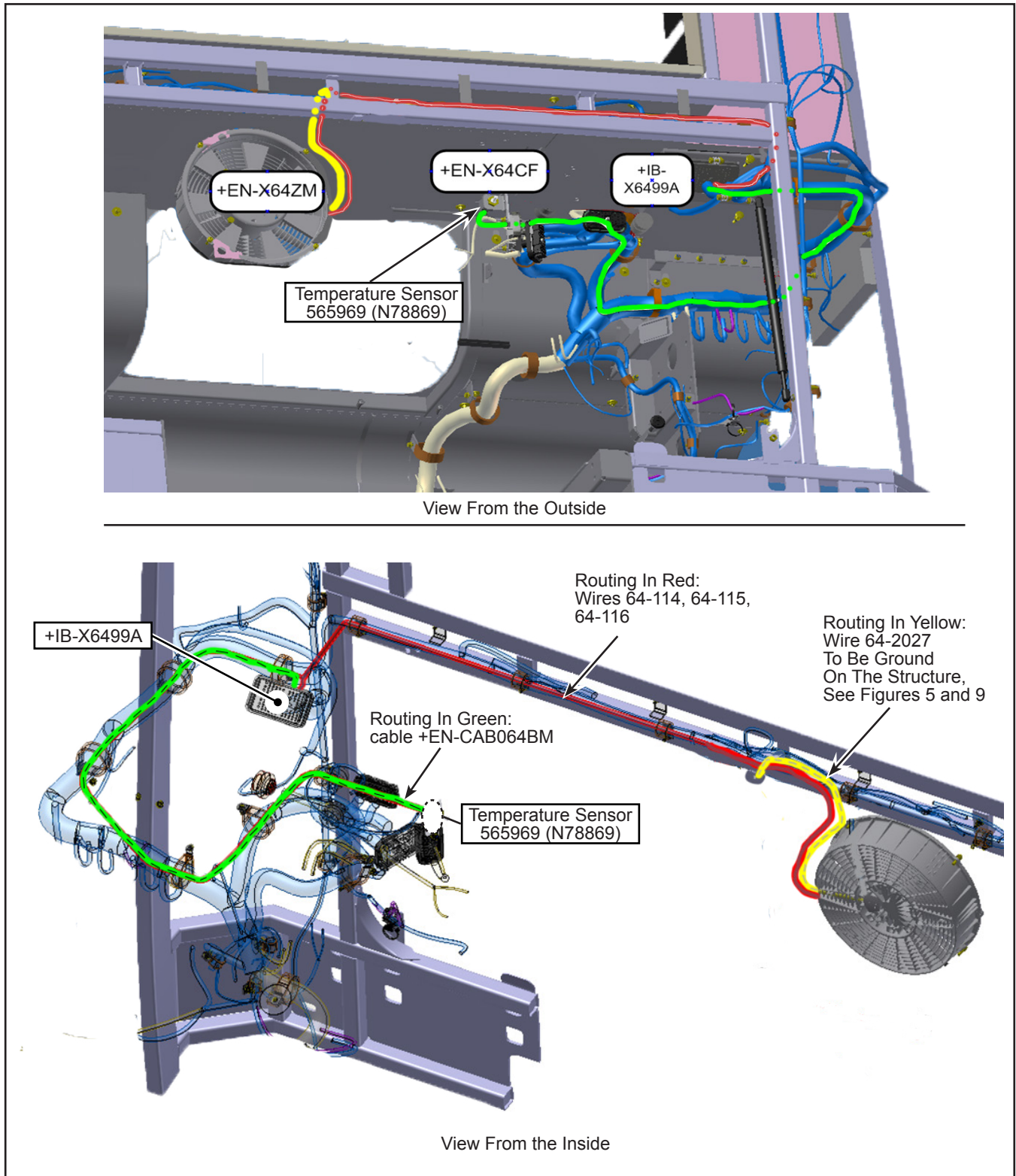

Figure 18 - Routing for the New Harness N632000532

- 1.36. Drill 21/64 in. (8mm) hole in the bracket of the structure for ground installation.
- 1.37. Remove the paint and clean the surface for a proper ground contact (see Figures 19 and Figure 21).

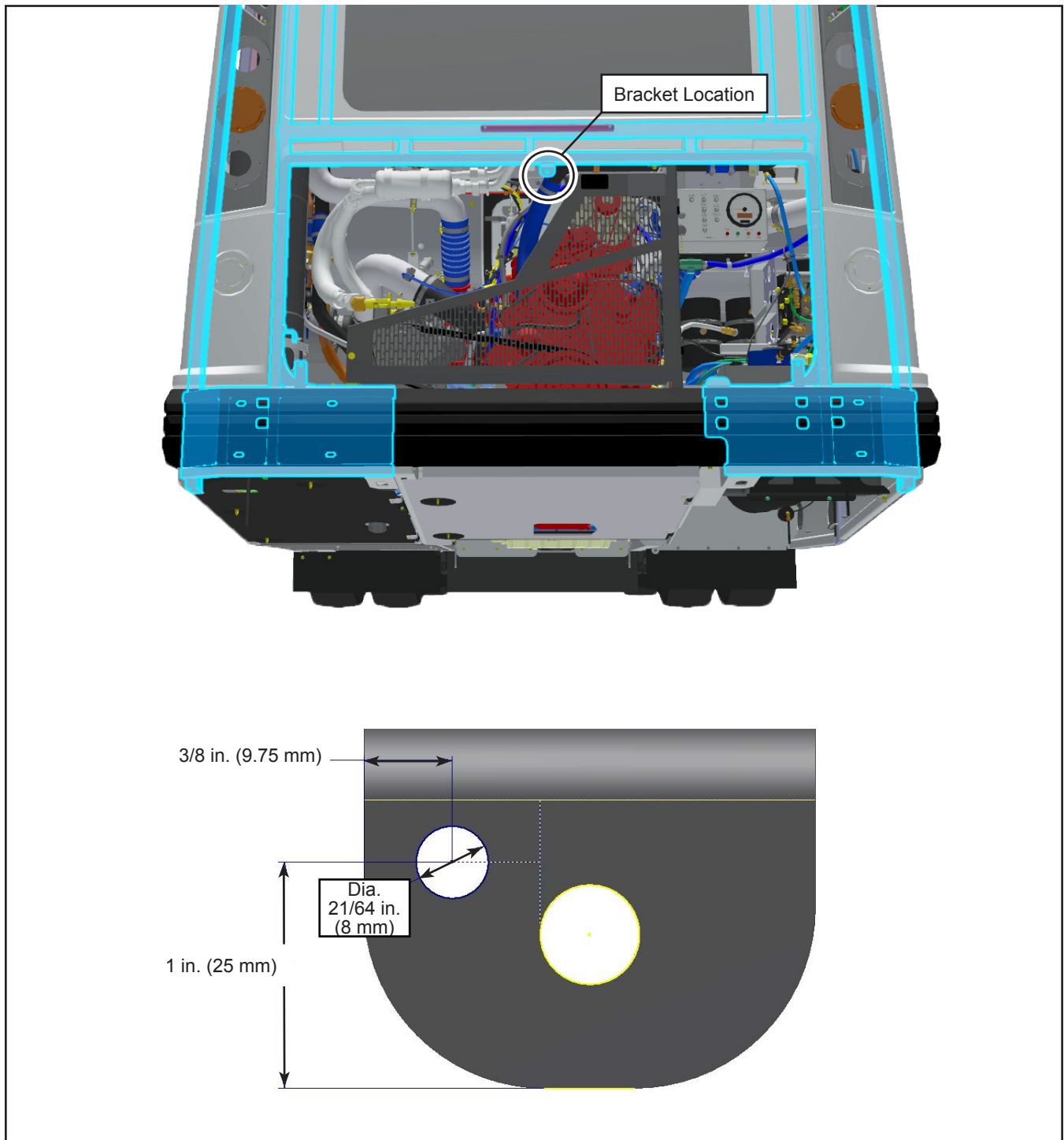

Figure 19 - Drill 8 mm (21/64 in.) for the Ground

- 1.38. Route harness N632000532 by following existing license plate harness towards the main engine harness 64 on the curb side and then up to the IB-X6499A connector (see Figure 18).
- 1.39. Secure harness N632000532 to the main harness with cable ties N56339 until temperature sensor location is reached.
- 1.40. Connect the temperature sensor to the harness as indicated in the electrical diagram (see Figure 20).

1.41. Install harness as shown in the electrical wire diagram (see Figure 20).

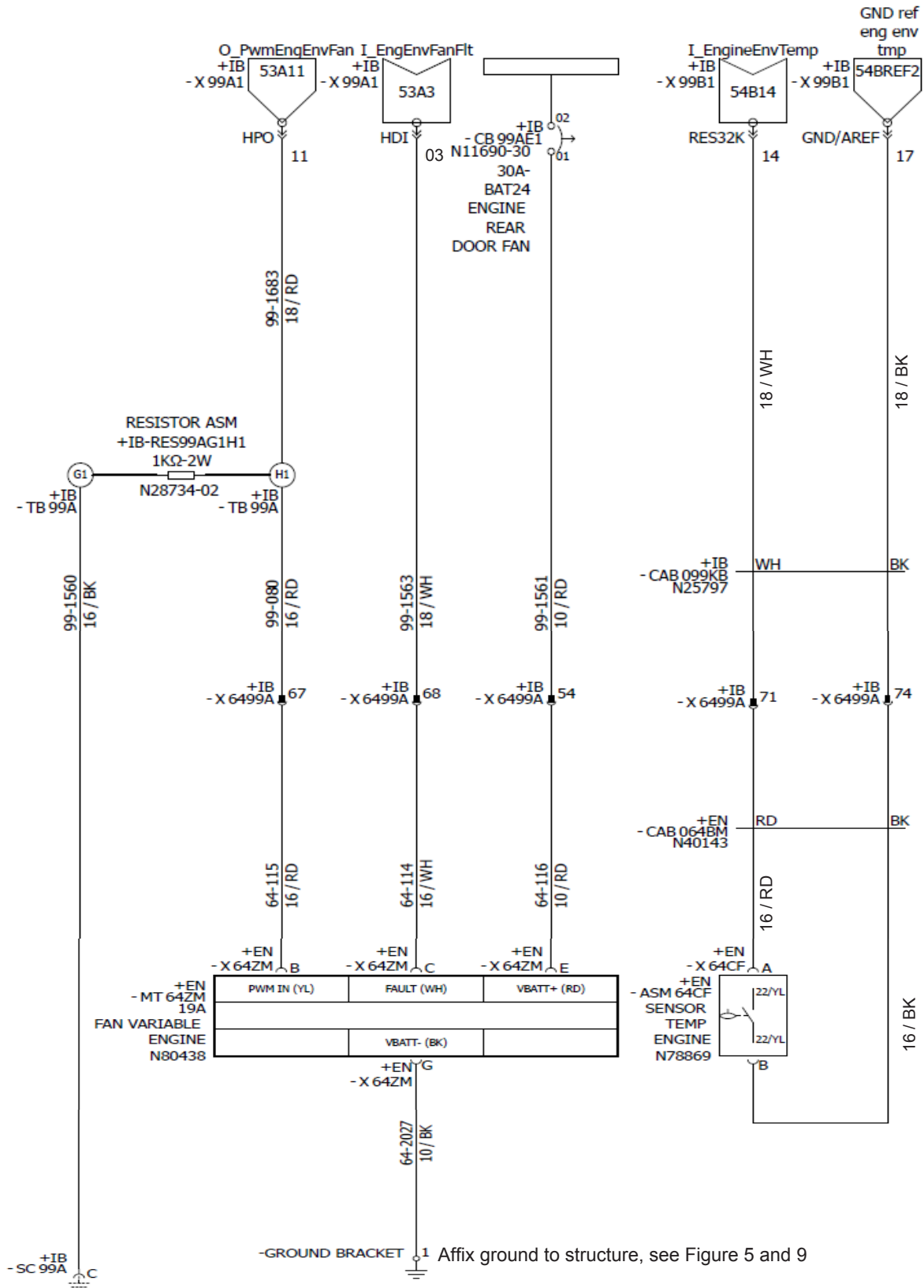

Figure 20 - Electrical diagram

- 1.42. Connect wire 64-2027 (10 BK) to the vehicle structure. Make sure there is no paint between the ground and the structure (see Figures 19 and Figure 21).
- 1.43. Apply anticorrosion Maxi-coat N35450 or equivalent to protect electrical connection.



Figure 21 - Install Ground

LOCATION: ENGINE COMPARTMENT IB CONNECTOR IB-X6499A

- 1.44. Connect wire 64-115 (16 RD) to connector +IB-X6499A at position 67.
- 1.45. Connect wire 64-114 (16 WH) to connector +IB-X6499A at position 68.
- 1.46. Connect wire 64-116 (10 RD) to connector +IB-X6499A at position 54.
- 1.47. Connect wire CAB064BM (16 RD) to connector +IB-X6499A at position 71.
- 1.48. Connect wire CAB064BM (16 BK) to connector +IB-X6499A at position 74.

LOCATION: AT THE REAR INSIDE OF THE VEHICLE IN THE IB ELECTRICAL PANEL.

Connector IB-X6499A. Pinning wires (see Figure 22).

- 1.49. Connect wire 99-080 (16 RD) to connector +IB-X6499A at position 67.
- 1.50. Connect wire 99-1563 (18 WH) to connector +IB-X6499A at position 68.
- 1.51. Connect wire 99-1561 (10 RD) to connector +IB-X6499A at position 54.
- 1.52. Connect wire CAB099KB (18 BK) to connector +IB-X6499A at position 74.
- 1.53. Connect wire CAB099KB (18 WH) to connector +IB-X6499A at position 71.

Module 53 (see Figure 22).

- 1.54. Connect wire 99-1683 (18 RD) to IOB module 53 connector +IB-X99A1 (HPO) at position 11.

Module 53 (see Figure 22).

- 1.55. Connect wire 99-1563 (18 WH) to IOA module 53 connector +IB-X99A1 (HDI) at position 01.

Module 54 (see Figure 22).

- 1.56. Connect wire CAB099KB (18 WH) to IOB module 54 connector +IB-X99B1 at position 14.
- 1.57. Connect wire CAB099KB (18 BK) to IOB module 54 connector +IB-X99B1 at position 17.

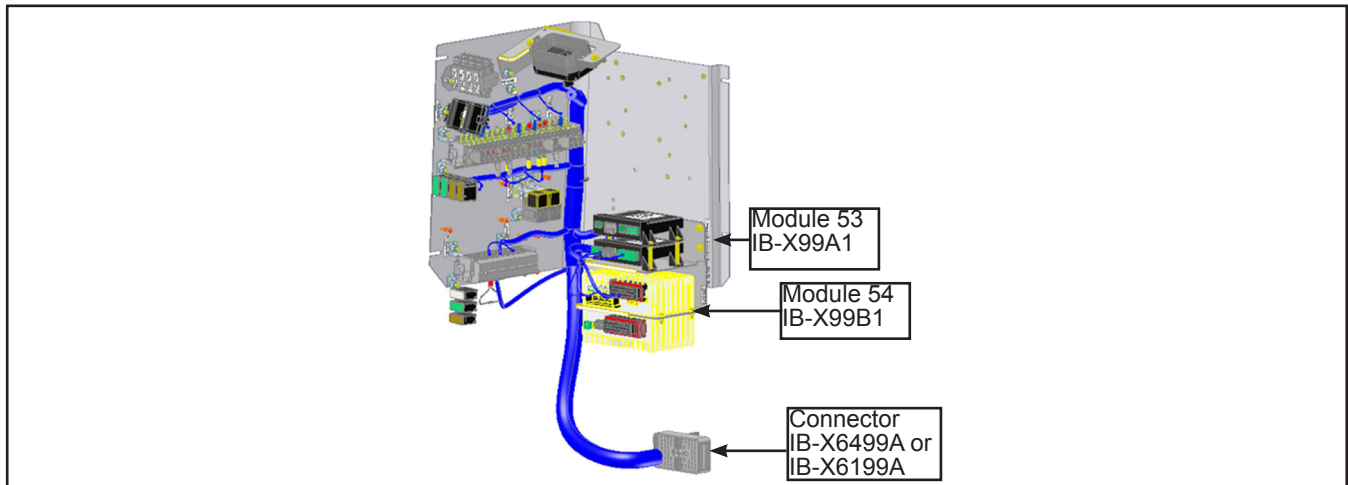

Figure 22 - IB Compartment

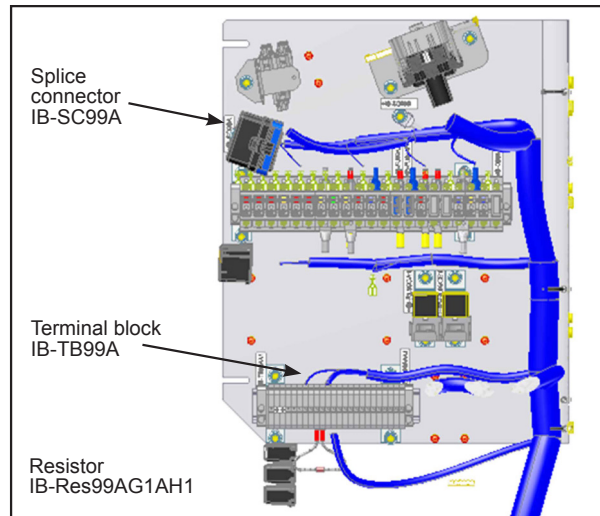

Figure 23 - IB Panel

- 1.58. Affix wire 99-1561 (10 RD) to +IB-CB99AE1.
- 1.59. Install the N11690-30 circuit breaker at location +IB-CB99AE.

Terminal block (see Figure 23).

- 1.60. Install the N28734-02 resistor across locations +IB-TB99A H1 and G1.
- 1.61. Connect wire 99-1683 (18 RD) to +IB-TB99A at position H1.
- 1.62. Connect wire 99-080 (16 RD) to +IB-TB99A at position H1.
- 1.63. Connect wire 99-1560 (16 BK) to +IB-TB99A at position G1.

Splice connector (see Figure 23).

- 1.64. Connect wire 99-1560 (16 BK) to splice connector +IB-SC99A at position C.

Wiring completion and testing.

- 1.65. Route the wires along the existing harness. Use high heat tie wraps to secure the wires.
- 1.66. Reconnect the negative battery cable. Turn on power switch in battery compartment.

Install the program.

- 1.67. Re-program the V-BEA system using the program listed in the client list (page 2 of this document) in accordance with section **16: ELECTRICAL SYSTEM** of the Nova Bus Maintenance manual.
- 1.68. When the vehicle is started, the fan will turn for 10 seconds if the wiring is correct and the program properly installed.

Validation of fan functions.

- 1.69. Raise sensor temperature above the applicable treshold. The use of a heat gun and thermometer gun is suggested.
- 1.70. Under this condition, the engine fan will turn at low speed (20%).
- 1.71. Raise temperature to 150 °F (65 °C), the engine fan will function at maximum speed (100%).

Fan operating conditions.**At ambient cold temperature, below 55 °F (13 °C). If the HVAC clutch is activated. Engine running.**

- 1.72. When engine compartment temperature is below 135 °F (57 °C), the fan does not operate.
- 1.73. When engine compartment temperature is 135 °F (57 °C), the fan operates at low speed (20%).
- 1.74. When engine compartment temperature is between 135 °F (57 °C) and 150 °F (65 °C), the speed of operation increases gradually.
- 1.75. When engine compartment temperature is 150 °F (65 °C) or above, the fan operates at maximum speed (100%).
- 1.76. Use cold air to lower the ambient sensor temperature below 55 °F (13 °C).
- 1.77. Use an heat gun on the engine compartment sensor to raise temperature from 135 °F (57 °C) to 150 °F (65 °C).

At ambient hot temperature, above 55 °F (13 °C). If the HVAC clutch is not activated. Engine running.

- 1.78. When engine compartment temperature is below 95 °F (35 °C), the fan does not operate.
- 1.79. When engine compartment temperature is 95 °F (35 °C), the fan operates at low speed (20%).
- 1.80. When engine compartment temperature is between 95 °F (35 °C) and 150 °F (65 °C), the speed of operation increases gradually.
- 1.81. When engine compartment temperature is 150 °F (65 °C) or above, the fan operates at maximum speed (100%).
- 1.82. Use an heat gun to raise temperature from 95 °F (35 °C) to 150 °F (65 °C).
- 1.83. Read % of fan speed on the multiplex at two temperatures. At temperature 95 °F (35 °C), the fan operates at low speed (20%). At 150 °F (65 °C), the fan operates at maximum speed (100%).

Master run switch on and engine not running.

- 1.84. When engine compartment temperature is above 110 °F (43 °C), the fan operates at low speed (20%).
- 1.85. When engine compartment temperature is below 110 °F (43 °C), the fan does not operate.
- 1.86. Read % of fan speed on the multiplex at two temperatures.

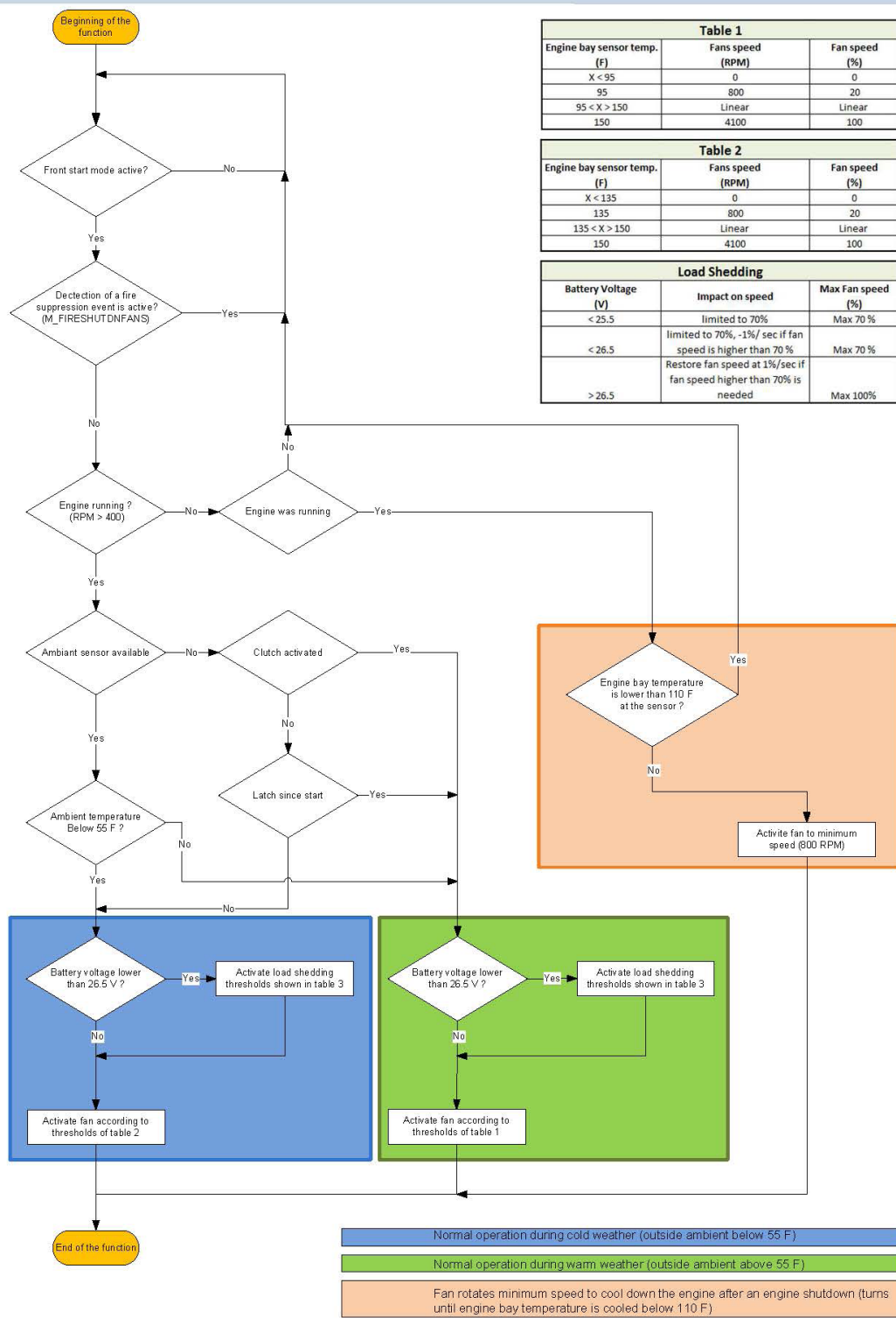

Figure 24 - Logic of Fan Operation

- 1.87. Remove the two dust pans (see Figure 25).
- 1.88. Remove the center mud flap (it could be reinstalled for the winter months) (see Figure 25).
- 1.89. Put the vehicle back in service. ❖

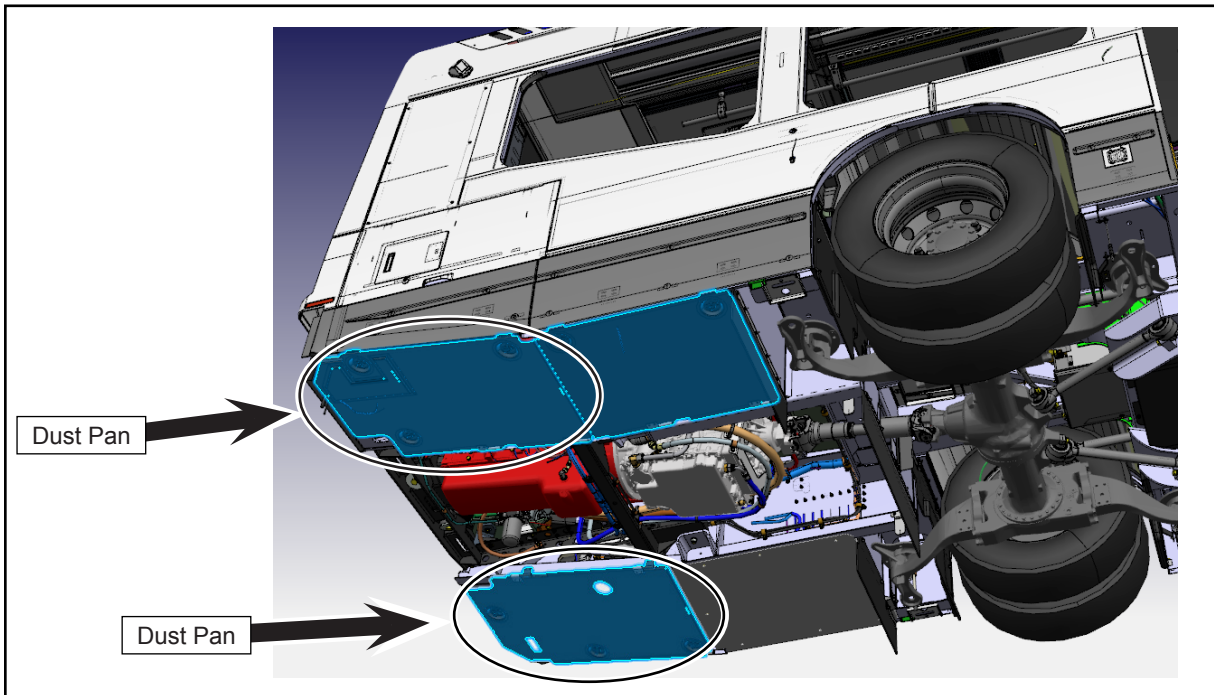

Figure 25 - Remove the Two Dust Pans

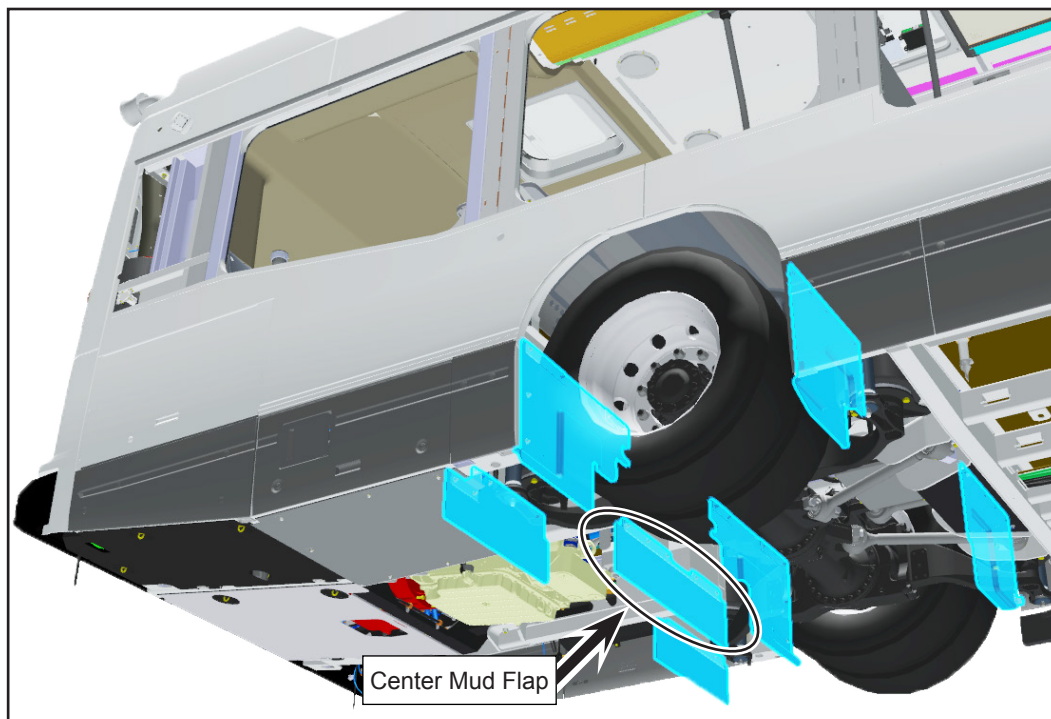

Figure 26 - Remove the Center Mud Flap