

Classification:

EM17-003

Reference:

ITB17-048

Date:

September 6, 2017

2013 JX35 AND 2014 – 2017 QX60; RADIATOR SHROUD AND COOLING FAN ASSEMBLY REPLACEMENT PROCEDURE

APPLIED VEHICLES: 2013 JX (L50)
 2014 – 2017 QX60 (L50)

SERVICE INFORMATION

When replacing the radiator shroud and cooling fan assembly for any reason, the engine coolant, air cleaner case, and air duct does not need to be removed as part of the procedure. Use this SERVICE PROCEDURE (in place of the ESM) and the CLAIMS INFORMATION in this bulletin. The ESM will be updated at a later date.

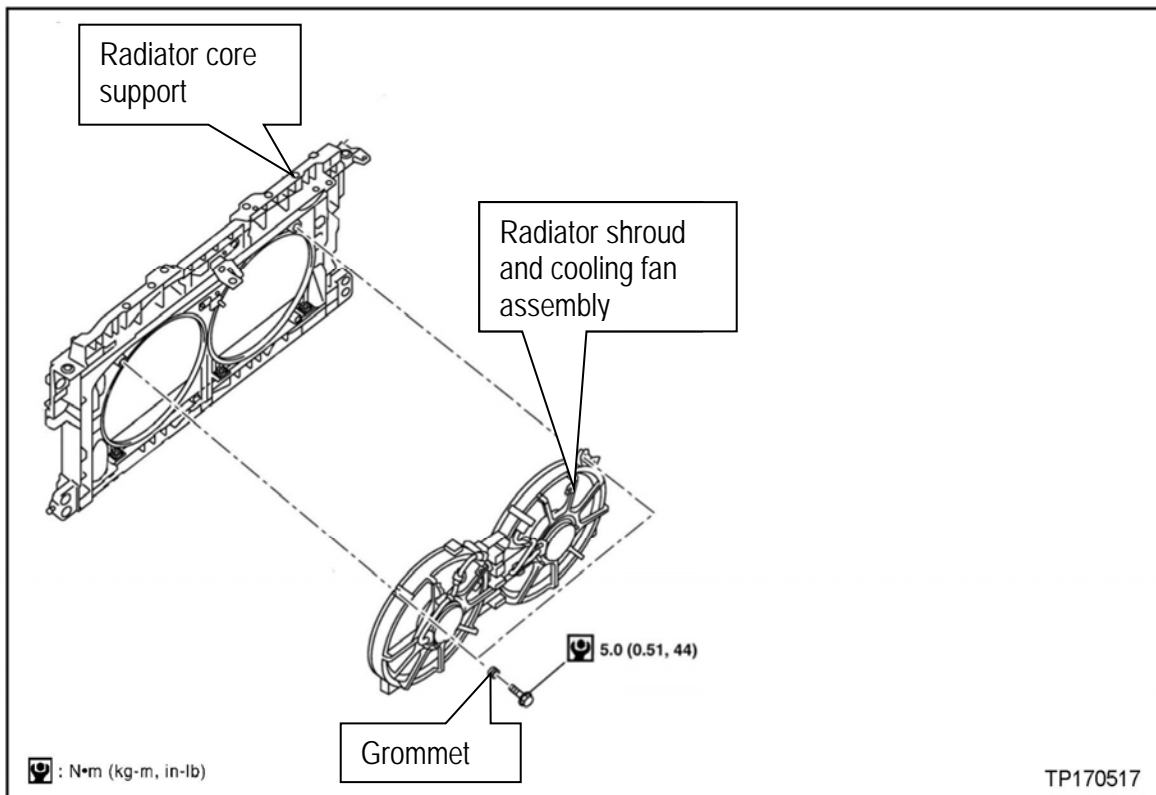

Figure 1

IMPORTANT: You MUST closely follow the entire SERVICE PROCEDURE as it contains information that is essential to successfully completing this repair.

Infiniti Bulletins are intended for use by qualified technicians, not 'do-it-yourselfers'. Qualified technicians are properly trained individuals who have the equipment, tools, safety instruction, and know-how to do a job properly and safely. NOTE: If you believe that a described condition may apply to a particular vehicle, DO NOT assume that it does. See your Infiniti retailer to determine if this applies to your vehicle.

SERVICE PROCEDURE

1. Turn the ignition ON.
2. Write down the radio settings.

Presets	1	2	3	4	5	6
AM						
FM 1						
FM 2						
SAT 1						
SAT 2						
SAT 3						
Bass	Treble		Balance	Fade	Spd Sen. Vol.	

3. Record (write down) any other customer settings that will be lost when the battery is disconnected.
 - Refer to the Electronic Service Manual (ESM) section PG-Power Supply, Ground, & Circuit Elements, for a listing of systems that may lose settings or memory when disconnecting the 12V battery.
 - Look in the PG section index for ADDITIONAL SERVICE WHEN REMOVING BATTERY NEGATIVE TERMINAL.
 - This list often includes items such as audio, HVAC, power windows, clock, etc.
4. Turn ignition OFF.

5. Disconnect battery negative terminal.
6. Remove cover on battery positive terminal.
7. Disconnect battery positive terminal.
8. Remove battery frame nuts.
9. Remove battery cover.
10. Remove battery.
11. Remove battery tray liner.

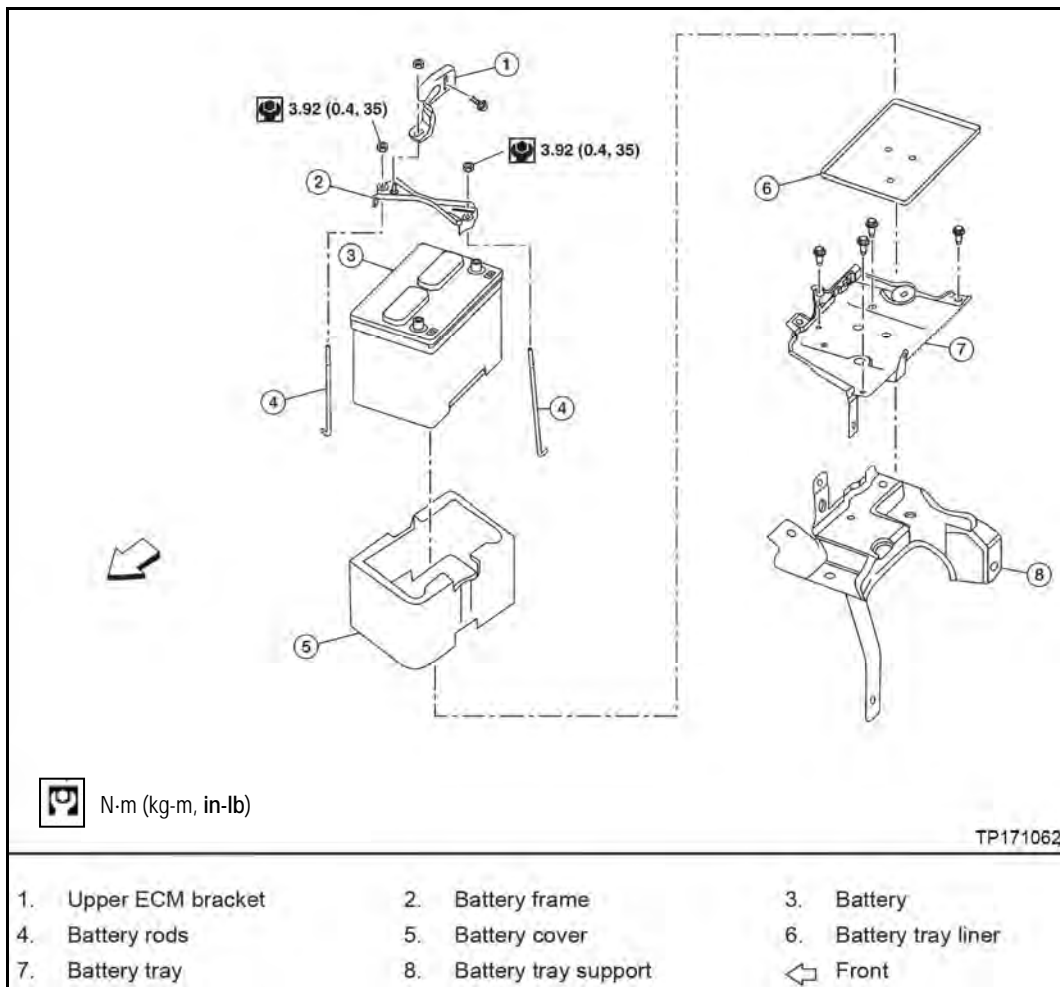

Figure 2

12. Remove 2 bolts securing the front air duct.

13. Remove the front air duct.

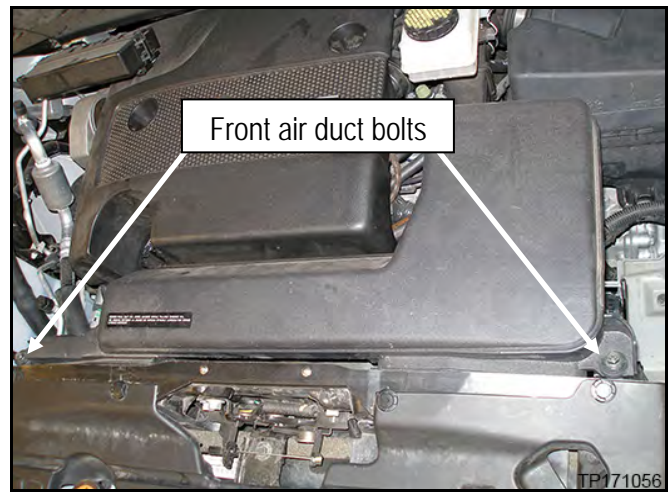

Figure 3

NOTE: Step 14 is for 2013 - 2016 model years only.

14. Remove 4 bolts securing the engine cover and remove the cover.

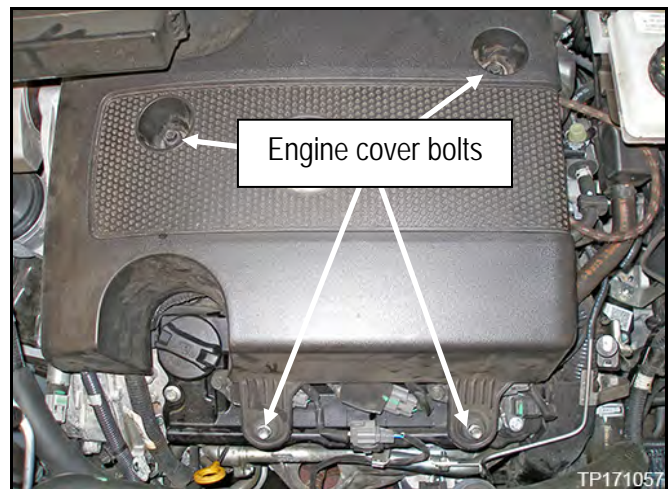

Figure 4

NOTE: Step 15 is for 2017 model year only.

15. Gently lift the engine cover to release the 4 tabs and remove the cover.

NOTE: The 2 rearward tabs are under the engine cover and cannot be seen.

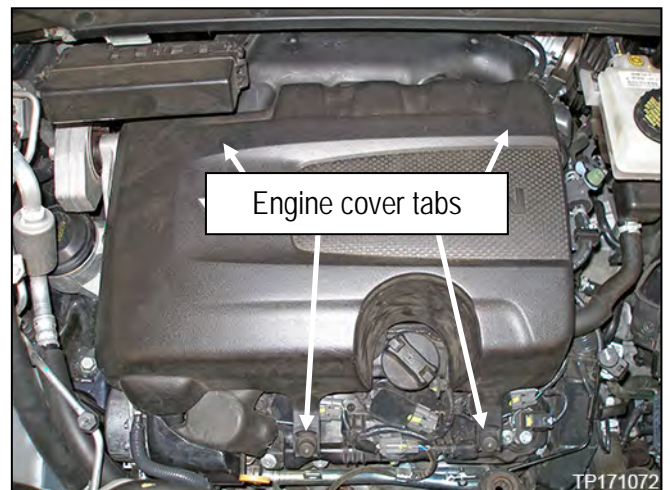

Figure 5

16. Remove ground bolt.

NOTE: 2013-2016 model years shown. 2017 model year is similar.

17. Disconnect harness clip.

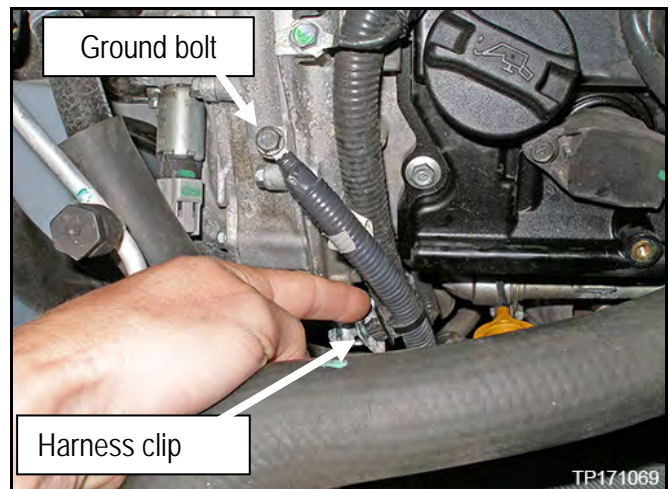

Figure 6

18. Disconnect clip securing upper radiator hose to radiator shroud.

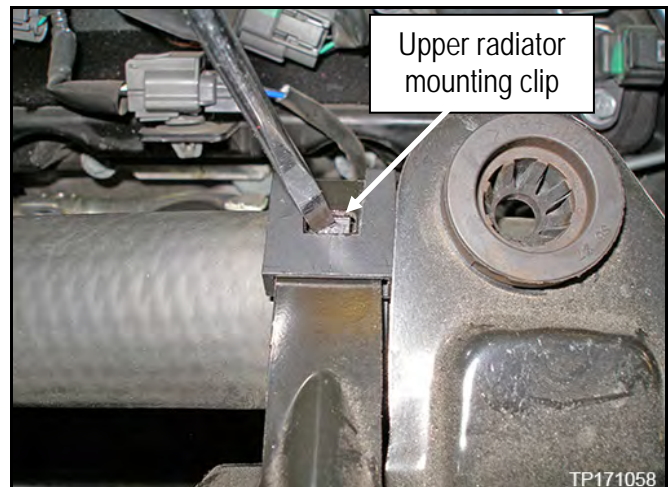

Figure 7

19. Temporarily secure upper radiator hose away from radiator shroud.

- Use a suitable strap to secure radiator hose.



Figure 8

NOTE: Secure the strap to the brake fluid reservoir bracket as shown in Figures 8 and 9.

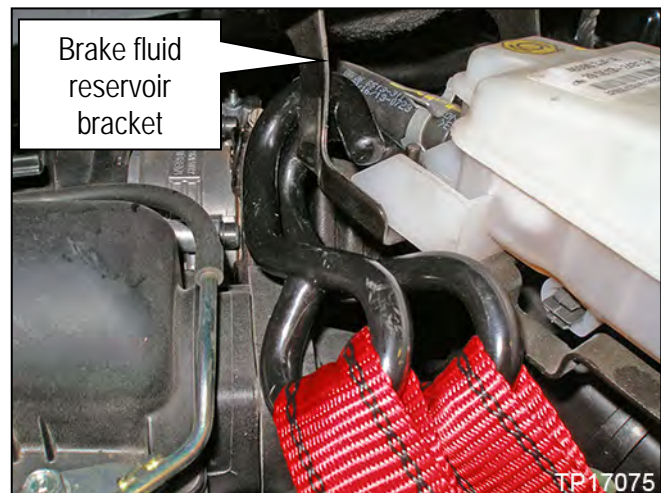

Figure 9

20. Remove the fan control module as follows;

- a. Disconnect the 3 electrical connectors on the fan control module.
- b. Remove the 2 bolts securing the fan control module to the radiator shroud.
- c. Remove the fan control module from the radiator shroud.

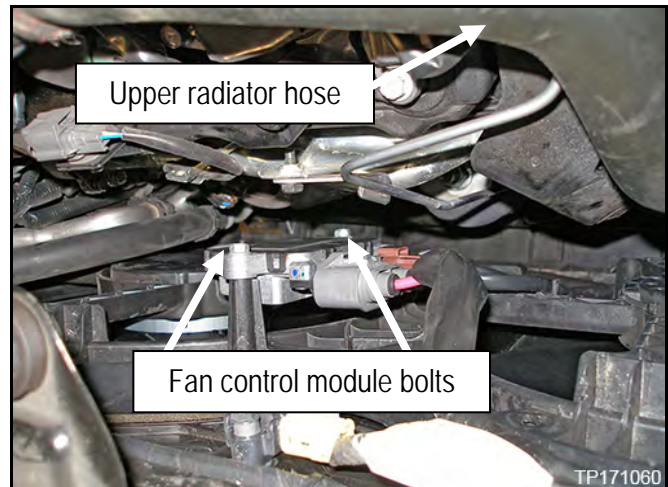

Figure 10

NOTE: Refer to Figure 11 for fan control module location (radiator shroud and cooling fan assembly removed from vehicle for clarification).

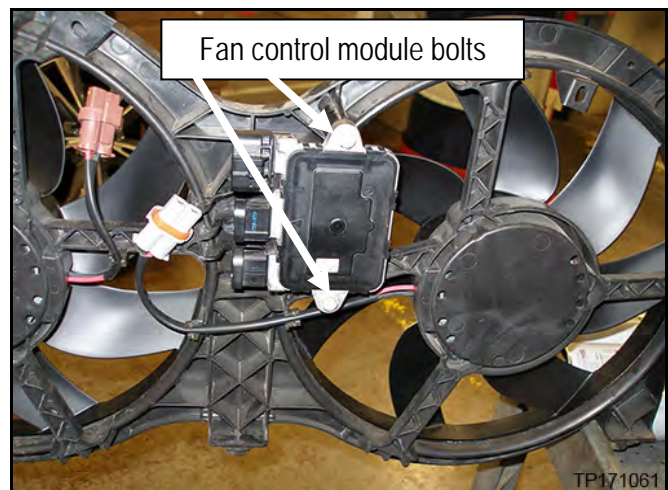

Figure 11

21. Release the fan control module harness clip from the radiator shroud and cooling fan assembly.

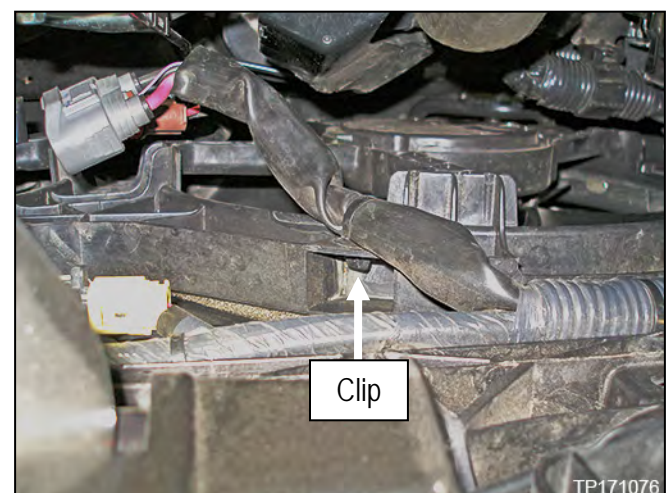

Figure 12

NOTE: Steps 22 and 23 are for 2013 - 2016 model years only.

22. Disconnect the ECM and TCM electrical connectors.

23. Remove the 4 ECM and TCM bracket bolts.

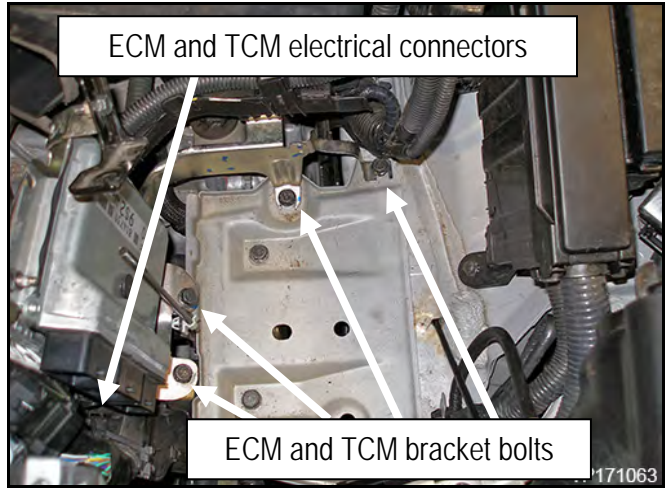

Figure 13

NOTE: Steps 24 and 25 are for 2017 model year only.

24. Disconnect the VTC module and TCM electrical connectors.

25. Remove the 4 VTC and TCM bracket bolts.

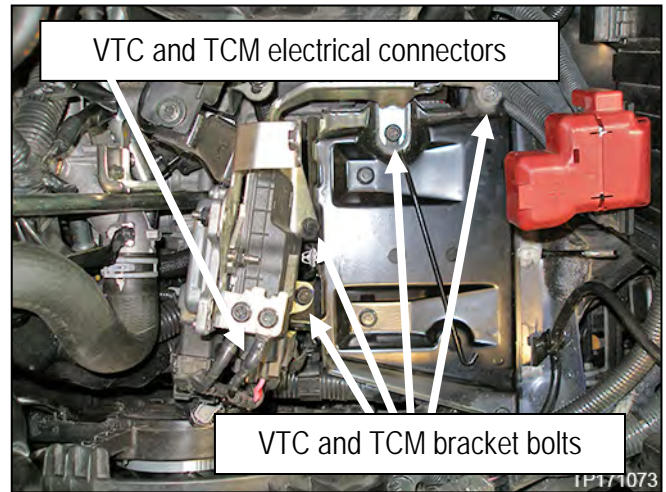

Figure 14

26. Lift up on air cleaner case (lower) to release the bracket.

NOTE: 2013-2016 model years shown. 2017 model year is similar.

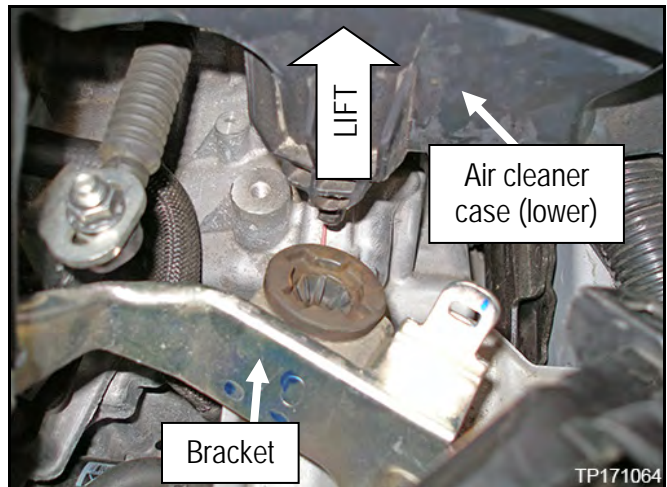

Figure 15

NOTE: Step 27 is for 2013 - 2016 model years only.

27. Release the driver's side harness clip from the battery tray support.

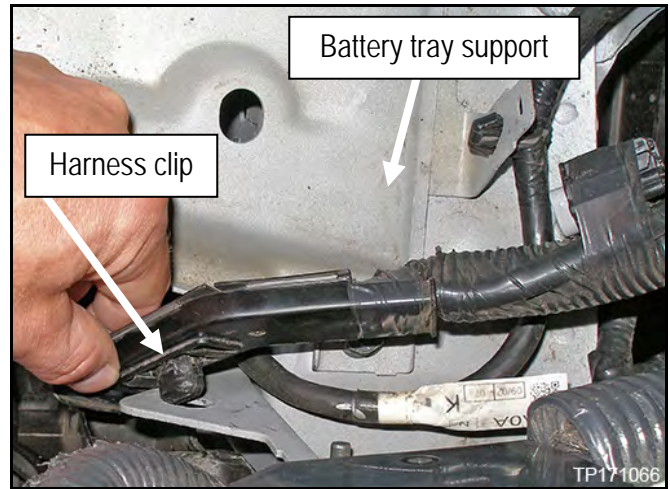

Figure 16

28. Remove the radiator shroud and cooling fan assembly mounting bolts (refer to Figure 18 on the next page for bolt locations).
29. Remove the radiator shroud and cooling fan assembly.
 - Start from the driver's side and lift the assembly out of the engine compartment.



Figure 17

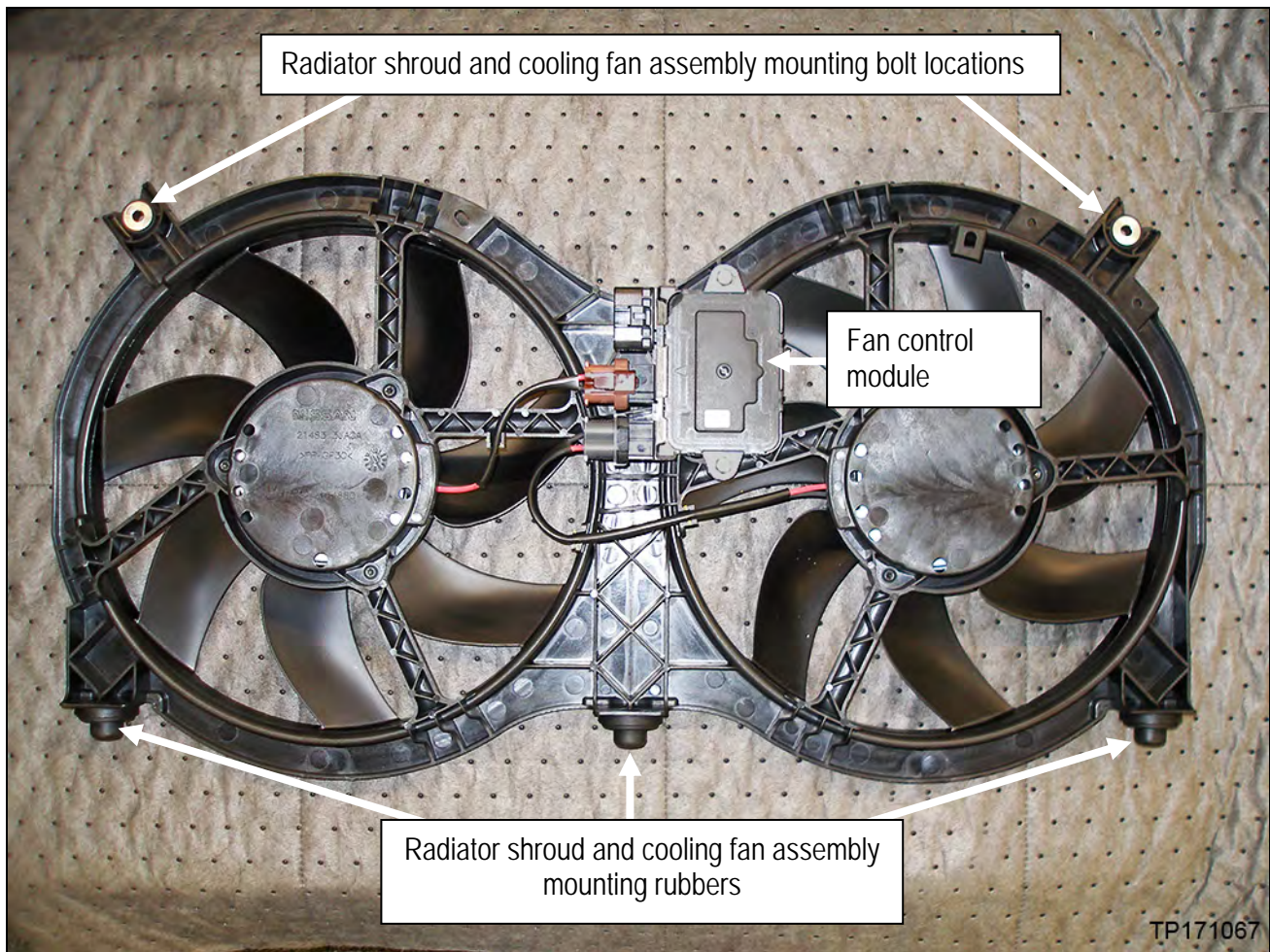

Figure 18

30. Before installing a **NEW** radiator shroud and cooling fan assembly, remove the fan control module electrical connectors, bolts, and fan control module (if equipped, see Step 20 on Page 7).
31. Verify OLD mounting rubbers are not stuck in the radiator core support.
 - NEW radiator shroud and cooling fan assembly will come with NEW mounting rubbers.
32. Reinstall all components in reverse order of removal.
33. Reset/reinitialize systems as needed.
 - Refer to the ESM section, PG – Power, Supply & Ground Elements for a listing of systems that require reset/initialization after reconnecting the 12V battery.
 - Look in the PG section index for **ADDITIONAL SERVICE WHEN REMOVING BATTERY NEGATIVE TERMINAL**.
 - This list often includes items such as audio, power windows, clock, etc.

CLAIMS INFORMATION

Submit a Primary Part (PP) type claim using the following claims coding:

DESCRIPTION	PFP	OP CODE	SYM	DIA	FRT
Replace Motor and Fan Assembly with Shroud	(1)	CC98AA	ZL	32	(2)

(1) Reference the Electronic Parts Catalog (FAST or equivalent) and use the Radiator Shroud and Cooling Fan Assembly part number as the Primary Failed Part (PFP).

(2) Reference the current Infiniti Warranty Flat Rate Manual and use the indicated flat rate time.

