

Bulletin Type.....: Field Fix (M)
Bulletin No.....: TS-M124
Bulletin Name.....: T-bolt clamp replacement
Bulletin Ref No.....: 700003234
PQR No.....: 500000006103
Release Date.....: 11.09.2017
Expiry Date.....: 11.09.2018
Vehicle Model.....: TS45
Fiat Rate Code.....: TSM124
Flat Rate Time.....: 50'

Subject: T-bolt clamp replacement

Summary : This technical service bulletin gives the instruction about how to replace the T-bolt clamp for TS 45 vehicles

Bulletin Responsible: Musa AKALIN

Published by&Approved by: Hakan GÜNERDEM

Welding on the Chassis

- Always disconnect the batteries (starting with the negative lead).
- Disconnect the connectors of electrical and electronic equipment (electronic control units, sensors and actuators) if they are less than 2 meters away from the chassis part to be welded or the earth terminal of the welding equipment.
- The earth terminal should never be attached to vehicle components such as engine, axles and springs. Arcing on these parts is not permitted, because of the risk of damage to bearings, springs, etc.
- The earth terminal must make good contact and be placed as close as possible to the part to be welded.
- Plastic pipes, rubber parts and parabolic springs should be well protected against welding spatter and temperatures higher than 70°.

SERVICE BULLETIN

Service bulletin expiry dates differ according to service bulletin type.

Definitions

Release Date: As of this date the bulletin is released and available on E-Doc. Modification parts can be ordered. The time period between the release date and the effective date may vary according to the procurement lead time.

Effective Date: As of this date specified amount of the total modification parts will be available on Spare Parts Stock. Modification parts can be ordered and the application can be performed. (except non-compliance and safety related campaigns, i.e. S-Type Bulletin)

Part Order Deadline: Last order date for modification parts. The part orders which will be placed after this date should be approved by Regional Coordinator.

Expiry Date: Expiration date for the application.

Bulletin Types

- **S-Type:** Application period of this bulletin is 18 months after the date of issue. S type bulletin is used for Recall Campaigns.



- **U-Type :** Application period of this bulletin is 12 months after the date of issue. U type bulletin is used for updates that need to be performed upon customer complaints.

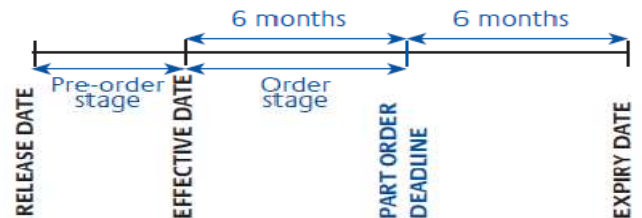

- **C-Type:** Application period of this bulletin is 12 months after the date of issue. C type bulletin is generally used for supplying technical instructions or other type of information to service network.

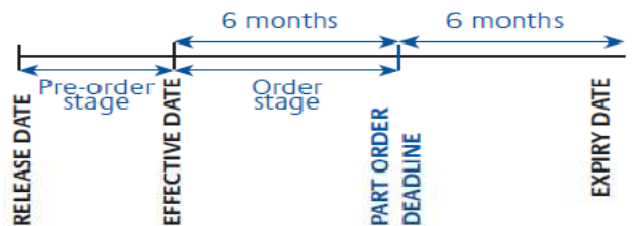

- **M-Type:** Application period of this bulletin is 12 months after the date of issue. M type bulletin is used for updates that should be implemented without waiting for customer complaints.

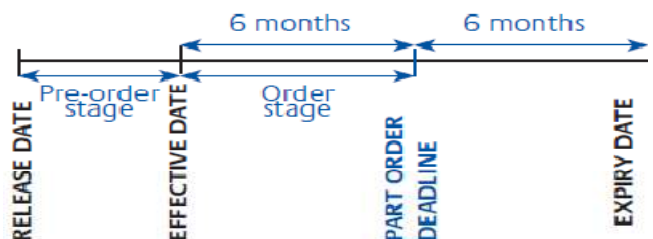

SERVICE BULLETIN

GENERAL PRECAUTIONS

1. Suggested Dress Code:





2- Before Starting the Work:

Always wear protective clothing. Do not wear any damaged or loose-fitting clothing and remove jewelry before starting the work. In case of long hair use hairnet. The illustration above shows some of the correct and incorrect clothing that should be worn during work. Sharp edges should be avoided e.g belts, watches, necklaces etc.



3- Interior materials protection:

Seats, trimming, upholstery stuff and carpeting should be protected with appropriate coverings.

Included Parts

No	Part Number	Definition	Figure	Quantity	Unit
1	9617-55	T-BOLT,FB,LARGE SPRING,95-103,FR U B		2	Pieces
2	9617-56	T-BOLT,FB,LARGE SPRING,105-113,FR B		6	Pieces

Excluded Parts

No	Part Number	Definition	Figure	Quantity	Unit
1	9617-50	T-BOLT CLAMP,FLOATING BRIDGE,95-103		2	Pieces
2	9617-52	T-BOLT CLAMP,FLOATING BRIDGE,108-116		6	Pieces

Application:

- 1- Location of the clamps to be replaced, see in. (see. **Figure-1**).

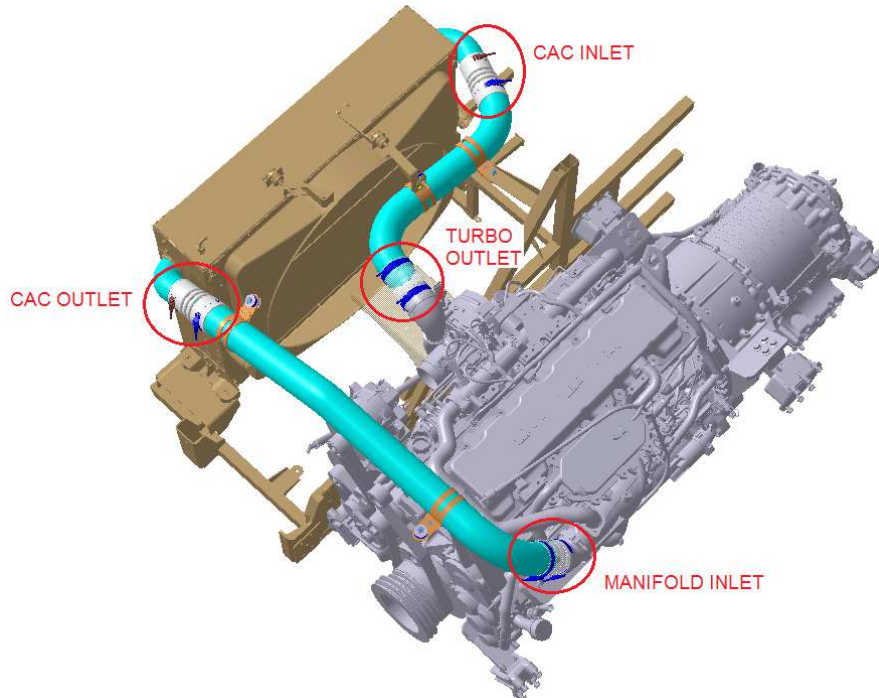

Figure-1

- 2- Replace the clamps indicated below with the new clamps.(Turbo outlet) (see. **Figure-2**).

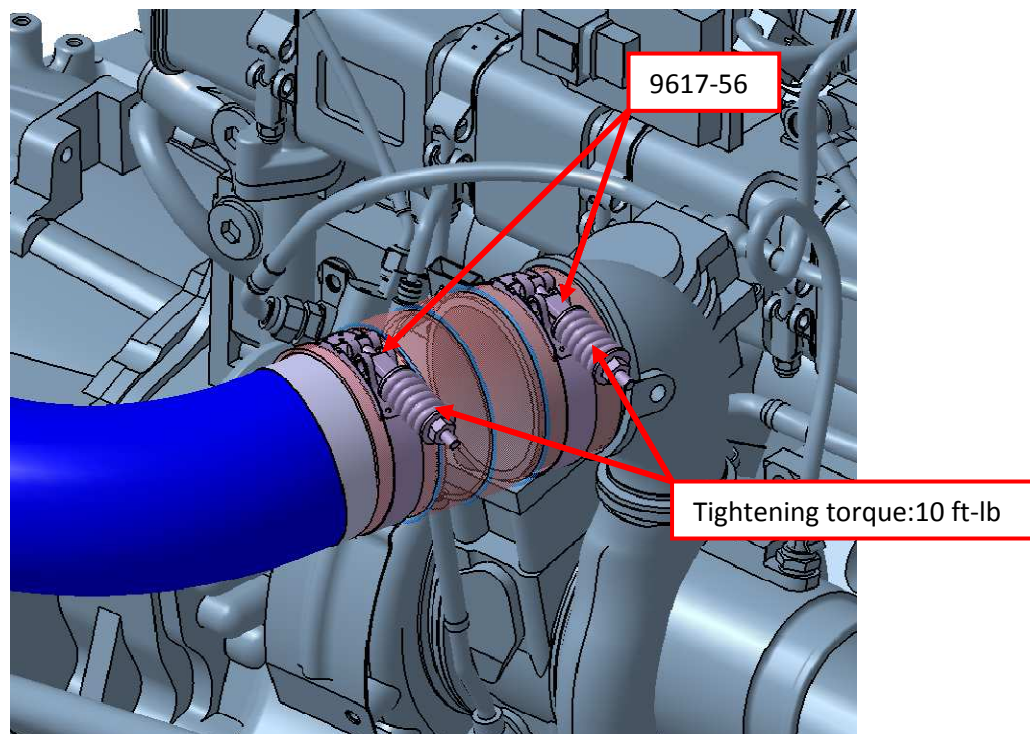

Figure-2

SERVICE BULLETIN

3- Replace the clamps indicated below with the new clamps.(CAC inlet). (See. Figure-3).

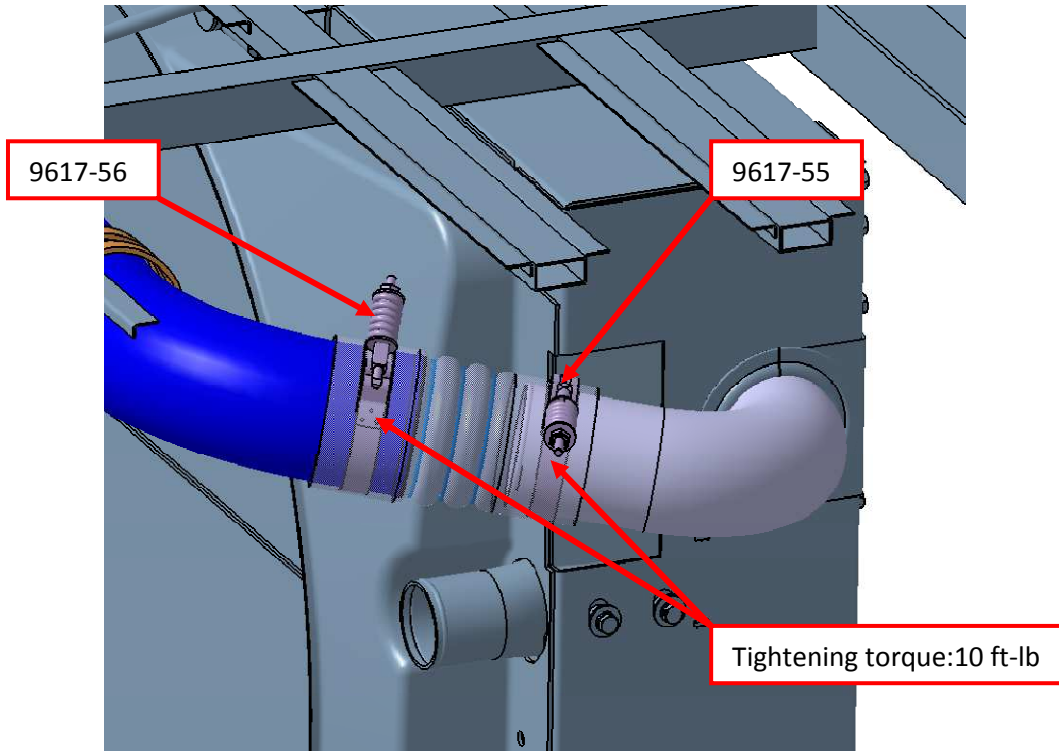

Figure-3

Note: In order to replace CAC Inlet clamps remove the cover indicated below. (See. Figure-5).

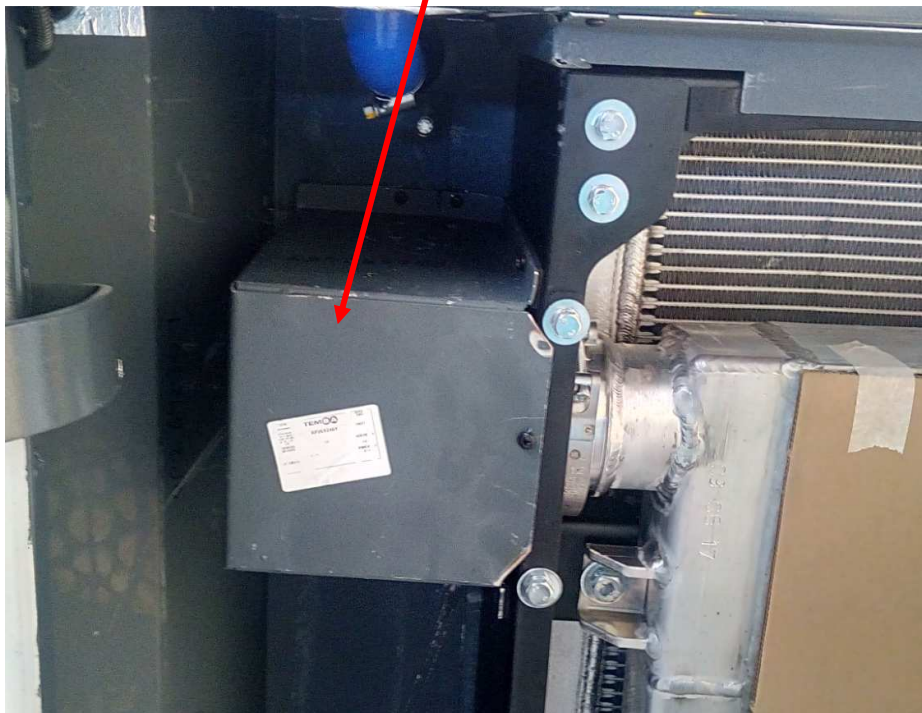

Figure-4

SERVICE BULLETIN

4. Replace the clamps indicated below with the new clamps.(CAC outlet). (See. Figure-5).

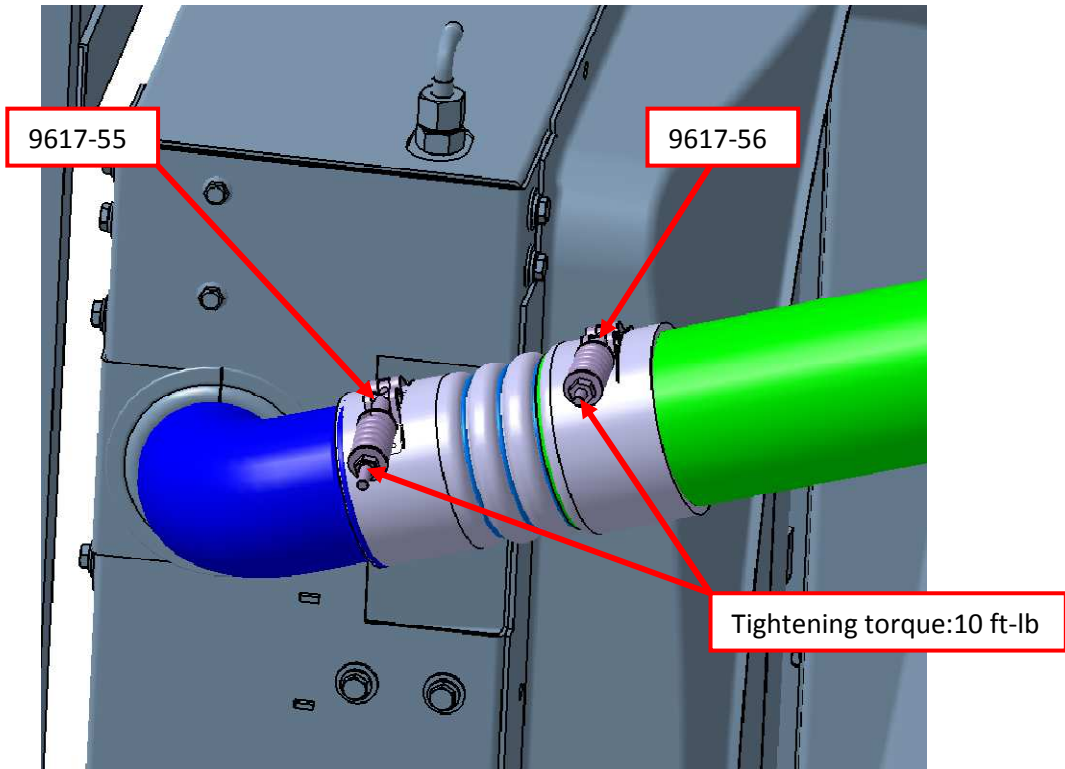

Figure-5

4- Replace the clamps indicated below with the new clamps.(Manifold inlet). (See. Figure-6).

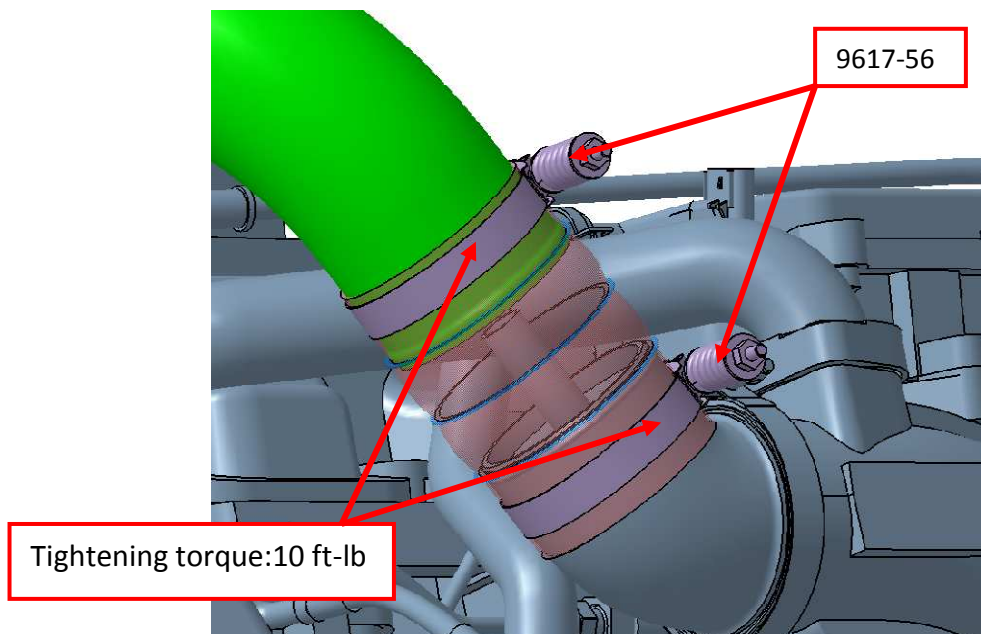

Figure-6

SERVICE BULLETIN

LABOR COST

APPLICATION	DURATION
Tool preparation	10 min.
Dismounting of the clamps	20 min.
Mounting of the new clamps	20 min.
Total Duration	50 min.

VEHICLE LIST

No	VIN	Country
1	NLTEJXU81E1000003	USA
2	NLTEJXU83E1000004	USA
3	NLTEJXU85E1000005	USA
4	NLTEJXU85F1000006	USA
5	NLTEJXU87F1000007	USA
6	NLTEJXU89F1000008	USA
7	NLTEJXU80F1000009	USA
8	NLTEJXU87F1000010	USA
9	NLTEJXU89F1000011	USA
10	NLTEJXU80F1000012	USA
11	NLTEJXU82F1000013	USA
12	NLTEJXU84F1000014	USA
13	NLTEJXU86F1000015	USA
14	NLTEJXU88F1000016	USA
15	NLTEJXU8XF1000017	USA
16	NLTEJXU81F1000018	USA
17	NLTEJXU83F1000019	USA
18	NLTEJXU8XF1000020	USA
19	NLTEJXU81F1000021	USA
20	NLTEJXU83F1000022	USA
21	NLTEJXU85F1000023	USA
22	NLTEJXU87F1000024	USA
23	NLTEJXU89F1000025	USA
24	NLTEJXU80F1000026	USA
25	NLTEJXU82F1000027	USA
26	NLTEJXU84F1000028	USA
27	NLTEJXU86F1000029	USA
28	NLTEJXU82F1000030	USA
29	NLTEJXU84F1000031	USA
30	NLTEJXU86F1000032	USA
31	NLTEJXU88F1000033	USA
32	NLTEJXU8XF1000034	USA

SERVICE BULLETIN

33	NLTEJXU81F1000035	USA
34	NLTEJXU83F1000036	USA
35	NLTEJXU85F1000037	USA
36	NLTEJXU87F1000038	USA
37	NLTEJXU89F1000039	USA
38	NLTEJXU85F1000040	USA
39	NLTEJXU87F1000041	USA
40	NLTEJXU89F1000042	USA
41	NLTEJXU80F1000043	USA
42	NLTEJXU82F1000044	USA
43	NLTEJXU84F1000045	USA
44	NLTEJXU86F1000046	USA
45	NLTEJXU88F1000047	USA
46	NLTEJXU8XF1000048	USA
47	NLTEJXU81F1000049	USA
48	NLTEJXU88F1000050	USA
49	NLTEJXU8XF1000051	USA
50	NLTEJXU81F1000052	USA
51	NLTEJXU83F1000053	USA
52	NLTEJXU85F1000054	USA
53	NLTEJXU87F1000055	USA
54	NLTEJXU89F1000056	USA
55	NLTEJXU80F1000057	USA
56	NLTEJXU82F1000058	USA
57	NLTEJXU84F1000059	USA
58	NLTEJXX84G1000060	USA
59	NLTEJXX86G1000061	USA
60	NLTEJXX88G1000062	USA
61	NLTEJXX8XG1000063	USA
62	NLTEJXX81G1000064	USA
63	NLTEJXX83G1000065	USA
64	NLTEJXX85G1000066	USA
65	NLTEJXX87G1000067	USA
66	NLTEJXX89G1000068	USA
67	NLTEJXX80G1000069	USA
68	NLTEJXX87G1000070	USA
69	NLTEJXX89G1000071	USA
70	NLTEJXX80G1000072	USA
71	NLTEJXX82G1000073	USA
72	NLTEJXX84G1000074	USA
73	NLTEJXX86G1000075	USA
74	NLTEJXY8XG1000076	USA
75	NLTEJXX8XG1000077	USA
76	NLTEJXX81G1000078	USA

SERVICE BULLETIN

77	NLTEJXX83G1000079	USA
78	NLTEJXX8XG1000080	USA
79	NLTEJXX81G1000081	USA
80	NLTEJXX83G1000082	USA
81	NLTEJXX85G1000083	USA
82	NLTEJXX87G1000084	USA
83	NLTEJXX89G1000085	USA
84	NLTEJXX80G1000086	USA
85	NLTEJXX82G1000087	USA
86	NLTEJXX84G1000088	USA
87	NLTEJXX86G1000089	USA
88	NLTEJXX82G1000090	USA
89	NLTEJXX84G1000091	USA
90	NLTEJXX86G1000092	USA
91	NLTEJXX88G1000093	USA
92	NLTEJXX8XG1000094	USA
93	NLTEJXX81G1000095	USA
94	NLTEJXX83G1000096	USA
95	NLTEJXX85G1000097	USA
96	NLTEJXX87G1000098	USA
97	NLTEJXX89G1000099	USA
98	NLTEJXX81G1000100	USA
99	NLTEJXX83G1000101	USA
100	NLTEJXX85G1000102	USA
101	NLTEJXX87G1000103	USA
102	NLTEJXX89G1000104	USA
103	NLTEJXX80G1000105	USA
104	NLTEJXX82G1000106	USA
105	NLTEJXX84G1000107	USA
106	NLTEJXX86G1000108	USA
107	NLTEJXX88G1000109	USA
108	NLTEJXX84G1000110	USA
109	NLTEJXX86G1000111	USA
110	NLTEJXX88G1000112	USA
111	NLTEJXX8XG1000113	USA
112	NLTEJXX81G1000114	USA
113	NLTEJXX83G1000115	USA
114	NLTEJXX85G1000116	USA
115	NLTEJXX87G1000117	USA
116	NLTEJXX89G1000118	USA
117	NLTEJXX80G1000119	USA
118	NLTEJXX87G1000120	USA
119	NLTEJXY80G1000121	USA
120	NLTEJXY82G1000122	USA

SERVICE BULLETIN

121	NLTEJXY84G1000123	USA
122	NLTEJXY86G1000124	USA
123	NLTEJXY88G1000125	USA
124	NLTEJXY8XG1000126	USA
125	NLTEJXY81G1000127	USA
126	NLTEJXY83G1000128	USA
127	NLTEJXY85G1000129	USA
128	NLTEJXY8XH1000130	USA
129	NLTEJXY81H1000131	USA
130	NLTEJXY83H1000132	USA
131	NLTEJXY85H1000133	USA
132	NLTEJXY87H1000134	USA
133	NLTEJXY89H1000135	USA
134	NLTEJXY80H1000136	USA
135	NLTEJXY82H1000137	USA
136	NLTEJXY84H1000138	USA
137	NLTEJXY86H1000139	USA
138	NLTEJXY82H1000140	USA
139	NLTEJXY84H1000141	USA
140	NLTEJXY86H1000142	USA
141	NLTEJXY88H1000143	USA
142	NLTEJXY8XH1000144	USA
143	NLTEJXY81H1000145	USA
144	NLTEJXY83H1000146	USA
145	NLTEJXY85H1000147	USA
146	NLTEJXY87H1000148	USA
147	NLTEJXY89H1000149	USA
148	NLTEJXY85H1000150	USA
149	NLTEJXY87H1000151	USA
150	NLTEJXY89H1000152	USA
151	NLTEJXY80H1000153	USA
152	NLTEJXY82H1000154	USA
153	NLTEJXY84H1000155	USA
154	NLTEJXY86H1000156	USA
155	NLTEJXY88H1000157	USA
156	NLTEJXY8XH1000158	USA
157	NLTEJXY81H1000159	USA
158	NLTEJXM83J1000160	USA
159	NLTEJXY8XH1000161	USA
160	NLTEJXY81H1000162	USA
161	NLTEJXY83H1000163	USA
162	NLTEJXY85H1000164	USA
163	NLTEJXY87H1000165	USA
164	NLTEJXY89H1000166	USA

SERVICE BULLETIN

165	NLTEJXY80H1000167	USA
166	NLTEJXY82H1000168	USA
167	NLTEJXY84H1000169	USA
168	NLTEJXY80H1000170	USA
169	NLTEJXM88J1000171	USA
170	NLTEJXM8XJ1000172	USA
171	NLTEJXM81J1000173	USA
172	NLTEJXM83J1000174	USA
173	NLTEJXM85J1000175	USA
174	NLTEJXM87J1000176	USA
175	NLTEJXM89J1000177	USA
176	NLTEJXM80J1000178	USA
177	NLTEJXM82J1000179	USA
178	NLTEJXM89J1000180	USA
179	NLTEJXM80J1000181	USA
180	NLTEJXM82J1000182	USA
181	NLTEJXM84J1000183	USA
182	NLTEJXM86J1000184	USA
183	NLTEJXM88J1000185	USA
184	NLTEJXM8XJ1000186	USA
185	NLTEJXM81J1000187	USA
186	NLTEJXM83J1000188	USA
187	NLTEJXM85J1000189	USA
188	NLTEJXM81J1000190	USA
189	NLTEJXM83J1000191	USA
190	NLTEJXM85J1000192	USA
191	NLTEJXM87J1000193	USA
192	NLTEJXM89J1000194	USA
193	NLTEJXM80J1000195	USA
194	NLTEJXM82J1000196	USA
195	NLTEJXM84J1000197	USA
196	NLTEJXM86J1000198	USA