

<b>Subject:</b> <b>SECOND-ROW SEAT WALK-IN LEVER DOES NOT WORK</b>	<b>Bulletin No.:</b> 09-036/17
	<b>Last Issued:</b> 08/09/2017

## BULLETIN NOTES

This bulletin supersedes the previously issued bulletin(s) listed below. The changes are noted in Red text.

Previous TSBs:	Date(s) Issued:
09-060/16	12/01/2016

## DESCRIPTION

### APPLICABLE MODEL(S)/VINS

2016-2017 CX-9 vehicles with VINs lower than JM3TC\*\*\*\*\*142166 (produced before May 22, 2017)

On some vehicles, the second-row seat back does not fold (B) or slide (C) forward when the walk-in lever (A) is pulled up to access to the 3rd row seats. Also, the recliner lever knob (D) may not operate on some vehicles.

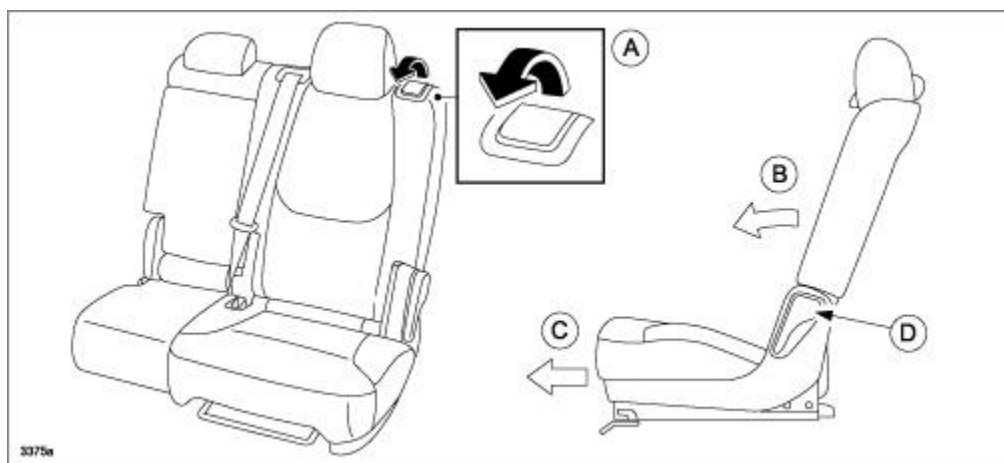

These concerns may be caused by a disconnected walk-in lever cable. To eliminate these concerns, the design of the walk-in lever has been changed according to the following:

**CONSUMER NOTICE:** The information and instructions in this bulletin are intended for use by skilled technicians. Mazda technicians utilize the proper tools/equipment and take training to correctly and safely maintain Mazda vehicles. These instructions should not be performed by "do-it-yourselfers." Customers should not assume this bulletin applies to their vehicle or that their vehicle will develop the described concern. To determine if the information applies, customers should contact their nearest authorized Mazda dealership. Mazda North American Operations reserves the right to alter the specifications and contents of this bulletin without obligation or advance notice. All rights reserved. No part of this bulletin may be reproduced in any form or by any means, electronic or mechanical---including photocopying and recording and the use of any kind of information storage and retrieval system ---without permission in writing.

	Mass-Production Change	Beginning VIN	Affected Model Year(s)	Mass-Production Change Date
1.	Walk-In Lever configuration change to reduce operational stroke.	JM3TC*****118947	2016	September 16, 2016
2.	Walk-In Lever internal mechanism reinforcement to prevent deformation / bending.	JM3TC*****142166	2016 and 2017	May 22, 2017

Customers having this concern should have their vehicle repaired using the following repair procedure.

**REPAIR PROCEDURE**

1. Verify the customer concern.
2. Replace the walk-in lever with a modified one according to the "WALK-IN LEVER REMOVAL/INSTALLATION PROCEDURE" instructions below.

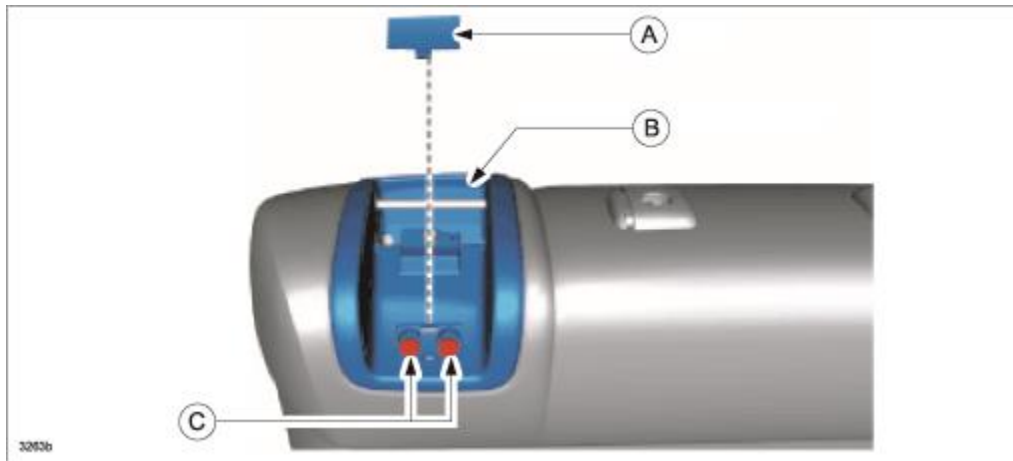

A	Cover
B	Walk-In Lever
C	Screws

3. Verify the walk-in lever and reclining lever operate correctly.

- If both systems work correctly, the repair is complete.
- If one of the following conditions (a or b) still exists, go to the next steps to check for possible binding / deformation of an internal mechanism of the walk-in system.

**CONSUMER NOTICE:** The information and instructions in this bulletin are intended for use by skilled technicians. Mazda technicians utilize the proper tools/equipment and take training to correctly and safely maintain Mazda vehicles. These instructions should not be performed by "do-it-yourselfers." Customers should not assume this bulletin applies to their vehicle or that their vehicle will develop the described concern. To determine if the information applies, customers should contact their nearest authorized Mazda dealership. Mazda North American Operations reserves the right to alter the specifications and contents of this bulletin without obligation or advance notice. All rights reserved. No part of this bulletin may be reproduced in any form or by any means, electronic or mechanical---including photocopying and recording and the use of any kind of information storage and retrieval system ---without permission in writing.

- a) When the walk-in lever is operated, the seat does not slide forward or the seatback completely folds down flat (it changes to flat luggage compartment space mode).  
 b) The recliner lever knob does not move or moves freely.

4. Remove the driver-side second-row seat and remove the side cover (A) (driver-side / rear console-side second-row seat) according to the instructions on MGSS online (SECOND-ROW SEAT SIDE COVER REMOVAL/INSTALLATION → Driver-side second-row seat → Rear console-side second-row seat side cover).



5. Inspect the cable bracket (A) for deformation / bending.

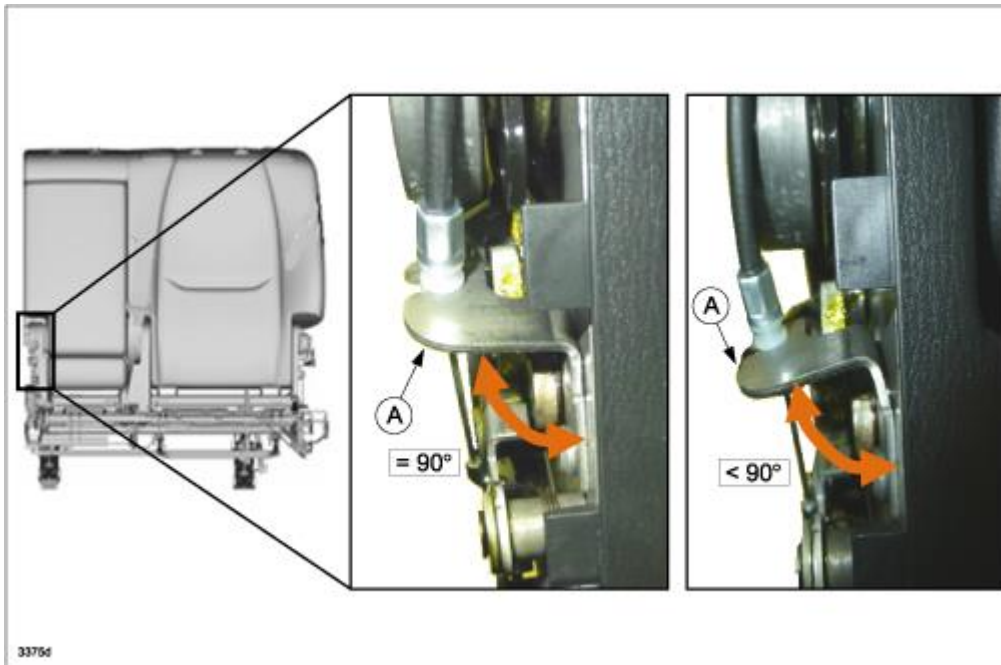

- If the cable bracket is bent (as shown above-right), replace the second-row seat cushion frame assembly with a modified one according to the instructions on MGSS online (SECOND-ROW SEAT BACK

**CONSUMER NOTICE:** The information and instructions in this bulletin are intended for use by skilled technicians. Mazda technicians utilize the proper tools/equipment and take training to correctly and safely maintain Mazda vehicles. These instructions should not be performed by "do-it-yourselfers." Customers should not assume this bulletin applies to their vehicle or that their vehicle will develop the described concern. To determine if the information applies, customers should contact their nearest authorized Mazda dealership. Mazda North American Operations reserves the right to alter the specifications and contents of this bulletin without obligation or advance notice. All rights reserved. No part of this bulletin may be reproduced in any form or by any means, electronic or mechanical---including photocopying and recording and the use of any kind of information storage and retrieval system ---without permission in writing.

COMPONENT REMOVAL/INSTALLATION)and (SECOND-ROW SEAT CUSHION REMOVAL/INSTALLATION).

**NOTE:** When replacing the frame, check the cable for damage and replace if necessary.

- If the cable bracket is not bent (as shown above-left), go to the next step.

**CAUTION:** If cable is disconnected from the bracket, be sure to place it back to the original position.

**NOTE:** There are three (3) installation grooves (A). Reinstall the cable in the same groove.



6. Verify links (A and B) move smoothly.

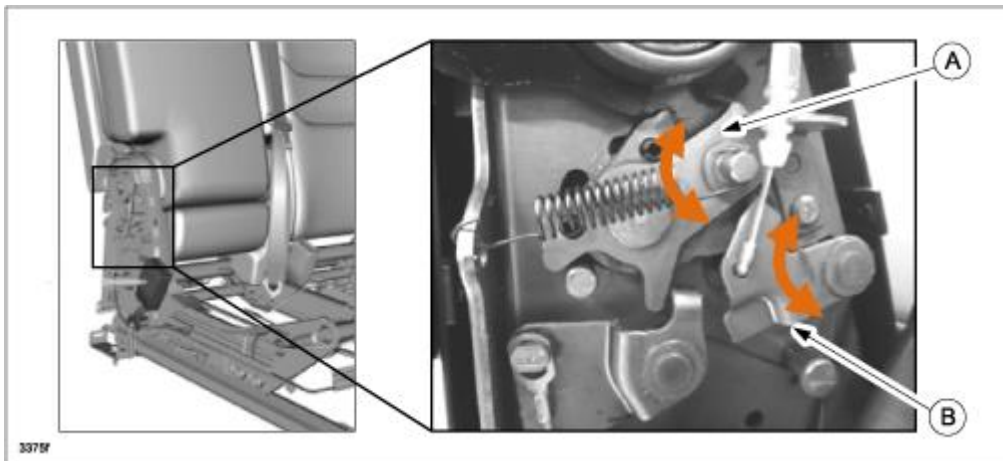

- If the links do not move, they may be binding with each other (C). Push link (B) with a screw driver (A) to release the binding. Verify the links move smoothly, then go to the next step.

**CONSUMER NOTICE:** The information and instructions in this bulletin are intended for use by skilled technicians. Mazda technicians utilize the proper tools/equipment and take training to correctly and safely maintain Mazda vehicles. These instructions should not be performed by "do-it-yourselfers." Customers should not assume this bulletin applies to their vehicle or that their vehicle will develop the described concern. To determine if the information applies, customers should contact their nearest authorized Mazda dealership. Mazda North American Operations reserves the right to alter the specifications and contents of this bulletin without obligation or advance notice. All rights reserved. No part of this bulletin may be reproduced in any form or by any means, electronic or mechanical---including photocopying and recording and the use of any kind of information storage and retrieval system ---without permission in writing.

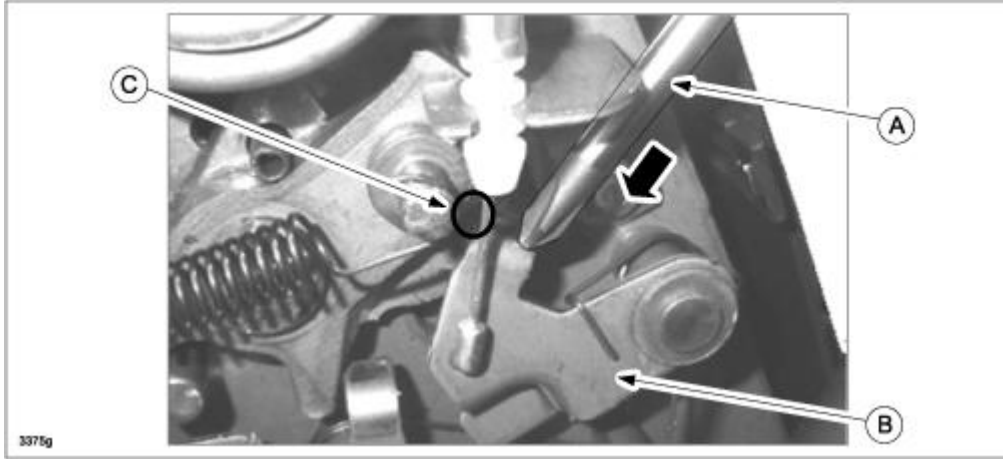

7. Using a screwdriver (B), remove the side cover (A) (driver-side/rear door-side second-row seat) according to the instructions on MGSS online (SECOND-ROW SEAT SIDE COVER REMOVAL/INSTALLATION → Driver-side second-row seat → Rear door-side second-row seat side cover). Replace the recliner lever knob (C) too.

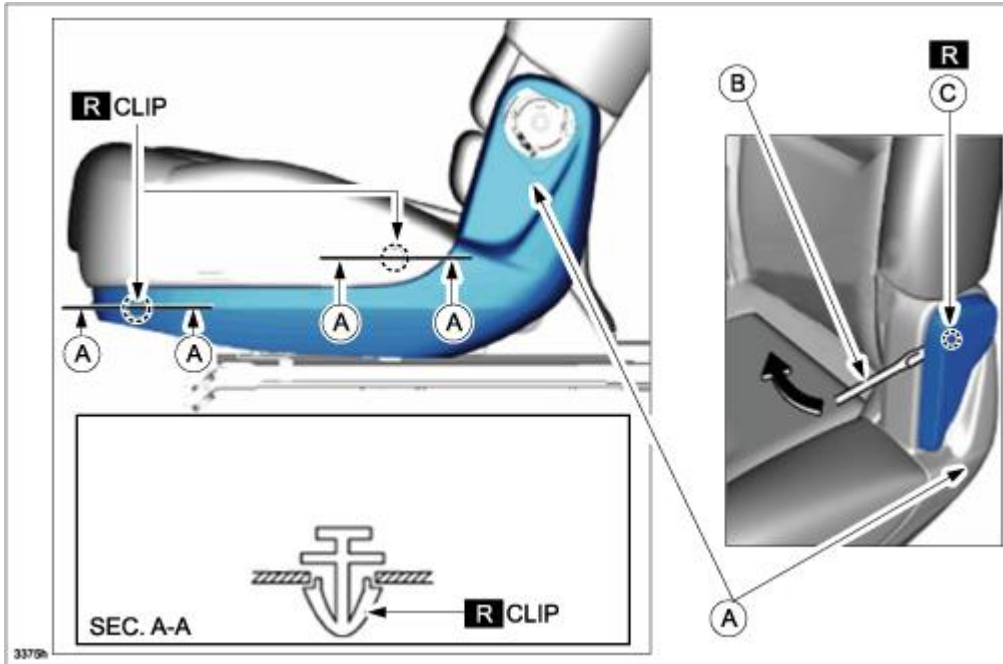

8. Inspect cable bracket (A) for bending.

**CONSUMER NOTICE:** The information and instructions in this bulletin are intended for use by skilled technicians. Mazda technicians utilize the proper tools/equipment and take training to correctly and safely maintain Mazda vehicles. These instructions should not be performed by "do-it-yourselfers." Customers should not assume this bulletin applies to their vehicle or that their vehicle will develop the described concern. To determine if the information applies, customers should contact their nearest authorized Mazda dealership. Mazda North American Operations reserves the right to alter the specifications and contents of this bulletin without obligation or advance notice. All rights reserved. No part of this bulletin may be reproduced in any form or by any means, electronic or mechanical---including photocopying and recording and the use of any kind of information storage and retrieval system ---without permission in writing.

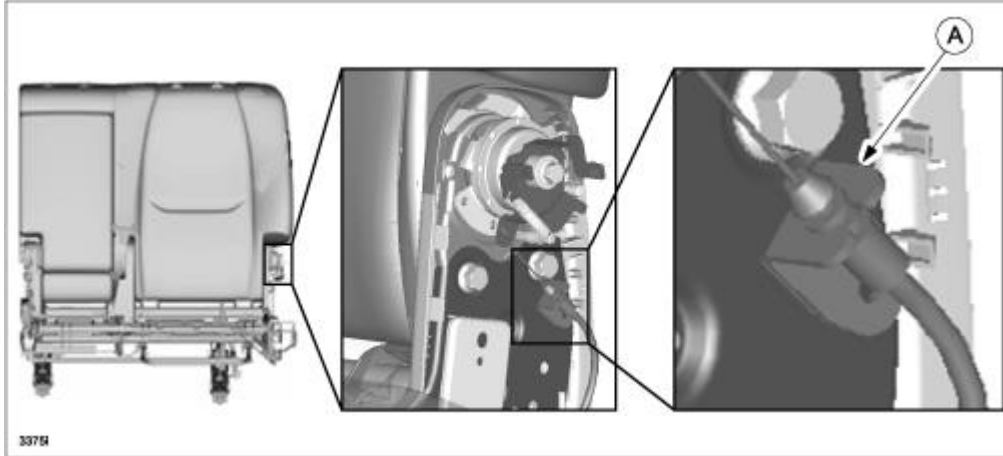

- If the cable bracket is bent, replace the second-row seat cushion frame assembly with a modified one according to the instructions on MGSS online (SECOND-ROW SEAT BACK COMPONENT REMOVAL/INSTALLATION) and (SECOND-ROW SEAT CUSHION REMOVAL/INSTALLATION).

**NOTE:** When replacing the frame, check the cable for damage and replace if necessary.

- If the cable bracket is not bent, go to the next step.

9. Inspect cable (A) for damage / coming out of bracket (B).

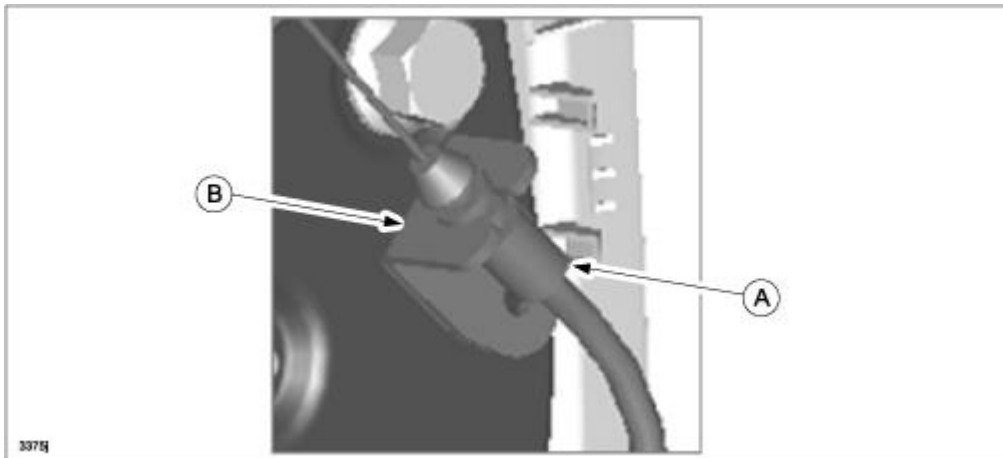

- If the cable is coming out of the bracket, check the white plastic part for damage.
- If the cable is damaged, replace it with a new one.
- If the cable is not damaged, install it back to the bracket.

**NOTE:** Use the same groove position to reinstall the cable.

**CONSUMER NOTICE:** The information and instructions in this bulletin are intended for use by skilled technicians. Mazda technicians utilize the proper tools/equipment and take training to correctly and safely maintain Mazda vehicles. These instructions should not be performed by "do-it-yourselfers." Customers should not assume this bulletin applies to their vehicle or that their vehicle will develop the described concern. To determine if the information applies, customers should contact their nearest authorized Mazda dealership. Mazda North American Operations reserves the right to alter the specifications and contents of this bulletin without obligation or advance notice. All rights reserved. No part of this bulletin may be reproduced in any form or by any means, electronic or mechanical---including photocopying and recording and the use of any kind of information storage and retrieval system ---without permission in writing.





**WALK-IN LEVER REMOVAL/INSTALLATION PROCEDURE:**

**Removal:**

1. Pull lever (A) and remove the cover (B) using a small size flat-blade screwdriver (C).

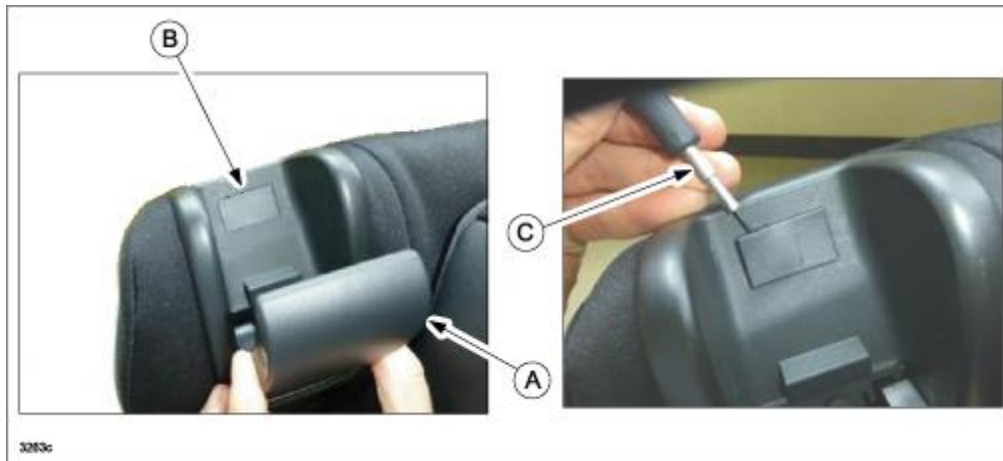

2. Remove two (2) screws (A).

**CONSUMER NOTICE:** The information and instructions in this bulletin are intended for use by skilled technicians. Mazda technicians utilize the proper tools/equipment and take training to correctly and safely maintain Mazda vehicles. These instructions should not be performed by "do-it-yourselfers." Customers should not assume this bulletin applies to their vehicle or that their vehicle will develop the described concern. To determine if the information applies, customers should contact their nearest authorized Mazda dealership. Mazda North American Operations reserves the right to alter the specifications and contents of this bulletin without obligation or advance notice. All rights reserved. No part of this bulletin may be reproduced in any form or by any means, electronic or mechanical---including photocopying and recording and the use of any kind of information storage and retrieval system ---without permission in writing.



3. Remove the lever assembly while disconnecting two (2) cables (A) on both sides of lever. Remove the cables through the gap (B).

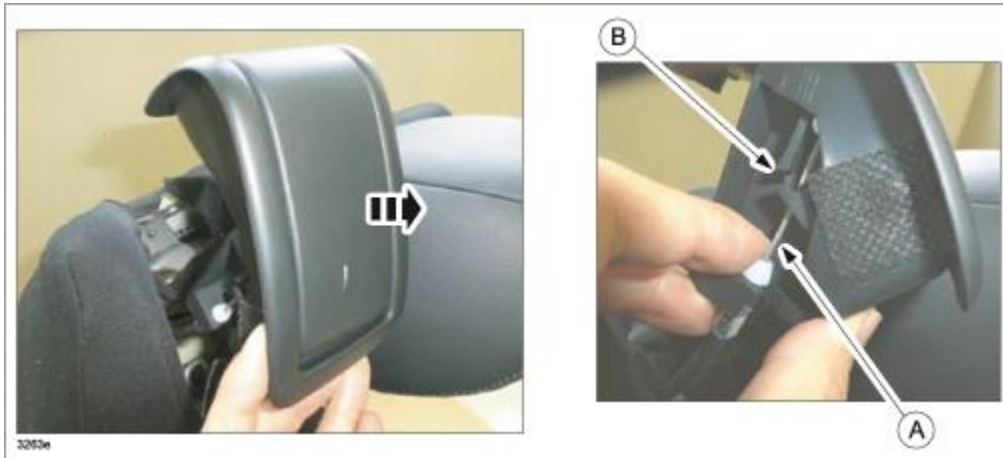

**CAUTION:** DO NOT lift the lever up by more than 110 mm (4.3 inches), otherwise it may be damaged.

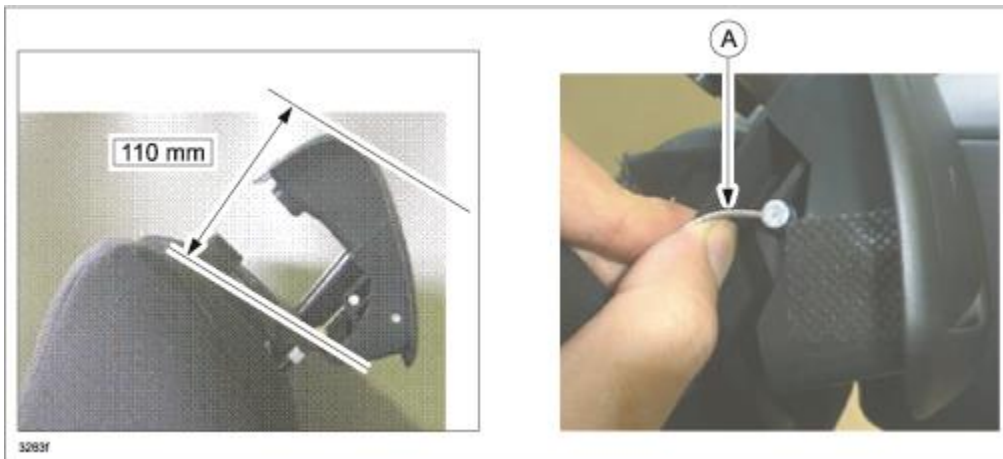

**CONSUMER NOTICE:** The information and instructions in this bulletin are intended for use by skilled technicians. Mazda technicians utilize the proper tools/equipment and take training to correctly and safely maintain Mazda vehicles. These instructions should not be performed by "do-it-yourselfers." Customers should not assume this bulletin applies to their vehicle or that their vehicle will develop the described concern. To determine if the information applies, customers should contact their nearest authorized Mazda dealership. Mazda North American Operations reserves the right to alter the specifications and contents of this bulletin without obligation or advance notice. All rights reserved. No part of this bulletin may be reproduced in any form or by any means, electronic or mechanical---including photocopying and recording and the use of any kind of information storage and retrieval system ---without permission in writing.



**Installation:**

1. Connect the two (2) cables to the new lever.
  - a. The two (2) cables can be installed to either side of the lever.
  - b. Push the plastic part (A) of the cable in the direction of the arrow shown below, until a click sound is heard.

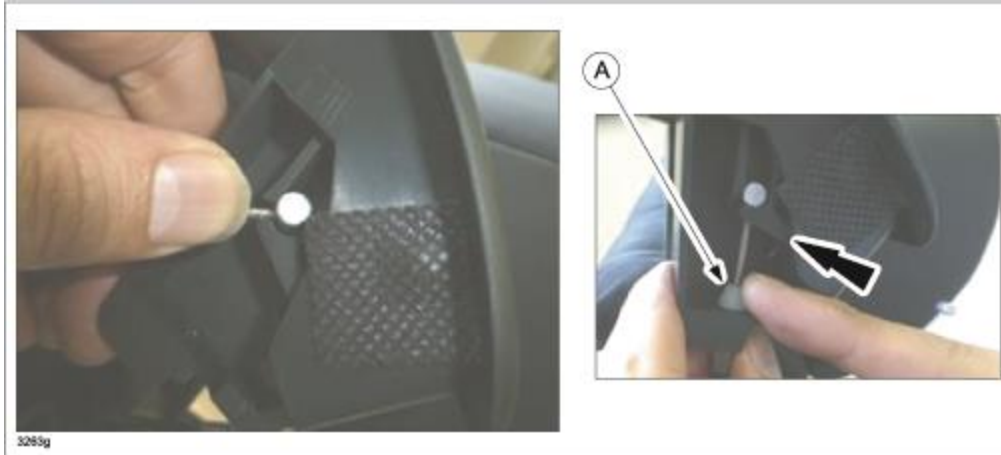

2. Engage the hook (A) at the front of the lever with the anchor (B) from the seat frame.



3. Push the lever assembly into the seat back, verifying that the front edge is securely engaged in the anchor.

**NOTE:** The example shown below (A) is NO GOOD. There should not be any clearance.

**CONSUMER NOTICE:** The information and instructions in this bulletin are intended for use by skilled technicians. Mazda technicians utilize the proper tools/equipment and take training to correctly and safely maintain Mazda vehicles. These instructions should not be performed by "do-it-yourselfers." Customers should not assume this bulletin applies to their vehicle or that their vehicle will develop the described concern. To determine if the information applies, customers should contact their nearest authorized Mazda dealership. Mazda North American Operations reserves the right to alter the specifications and contents of this bulletin without obligation or advance notice. All rights reserved. No part of this bulletin may be reproduced in any form or by any means, electronic or mechanical---including photocopying and recording and the use of any kind of information storage and retrieval system ---without permission in writing.

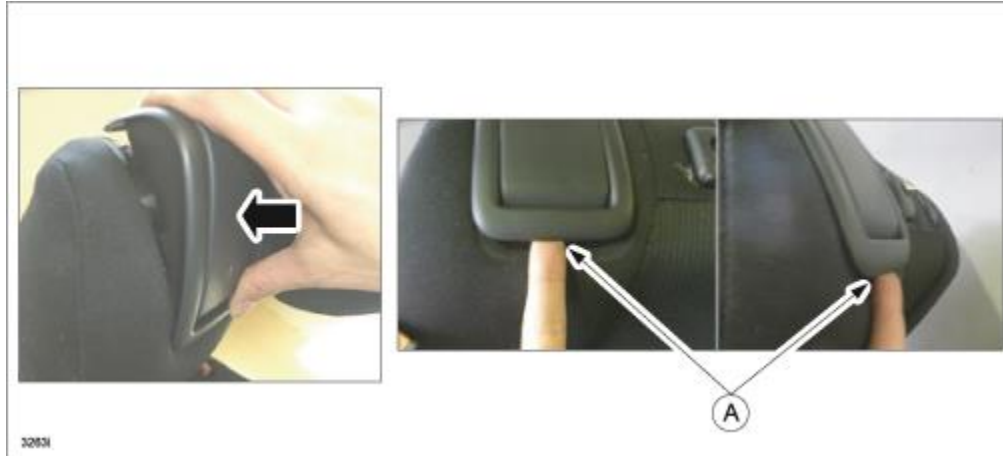

4. Tighten two (2) screws.



5. Install the cover (A) by pushing it until a click sound is heard.

**NOTE:** The cut (B) in the cover should face in the direction of the arrow, otherwise, the cap cannot be installed.

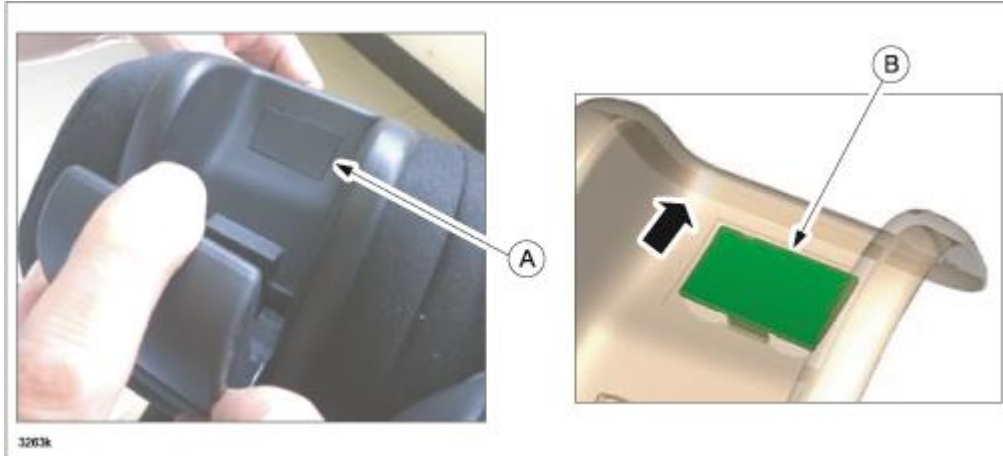

6. Verify the repair.

## PARTS INFORMATION

Part Number	Description	Qty.	Notes
TKY1-88-15Y	Walk-In Lever Unit	1	Interior color: TC5 (Brown)
TKY9-88-15Y	Walk-In Lever Unit	1	Interior color: TC2, 3, 4 (Beige)
TKY8-88-15Y	Walk-In Lever Unit	1	Interior color: TC0, 1 (Black)
TK48-88-263D	Second row seat cushion frame (LH)	1	US and Canada - Cloth seat
TK79-88-263D	Second row seat cushion frame (LH)	1	US and Canada - Leather seat
TK93-88-263D	Second row seat cushion frame (LH)	1	Mexico - Cloth seat
TK94-88-263D	Second row seat cushion frame (LH)	1	Mexico - Leather seat
TK48-88-585 02	Recliner lever Knob (LH)	1	Interior color: TC0, 1 (Black)
TK48-88-2H5 15	Recliner lever Knob (LH)	1	Interior color: TC5 (Brown)
TK48-88-2H5 2A	Recliner lever Knob (LH)	1	Interior color: TC2, 3, 4 (Beige)
KD45-88-585	Clip	2	---
TK48-88-489	Cable	1	---
H380-88-225	Bands	6	Bands are cut when removing cables

## PARTS LOCATION:

**CONSUMER NOTICE:** The information and instructions in this bulletin are intended for use by skilled technicians. Mazda technicians utilize the proper tools/equipment and take training to correctly and safely maintain Mazda vehicles. These instructions should not be performed by "do-it-yourselfers." Customers should not assume this bulletin applies to their vehicle or that their vehicle will develop the described concern. To determine if the information applies, customers should contact their nearest authorized Mazda dealership. Mazda North American Operations reserves the right to alter the specifications and contents of this bulletin without obligation or advance notice. All rights reserved. No part of this bulletin may be reproduced in any form or by any means, electronic or mechanical---including photocopying and recording and the use of any kind of information storage and retrieval system ---without permission in writing.

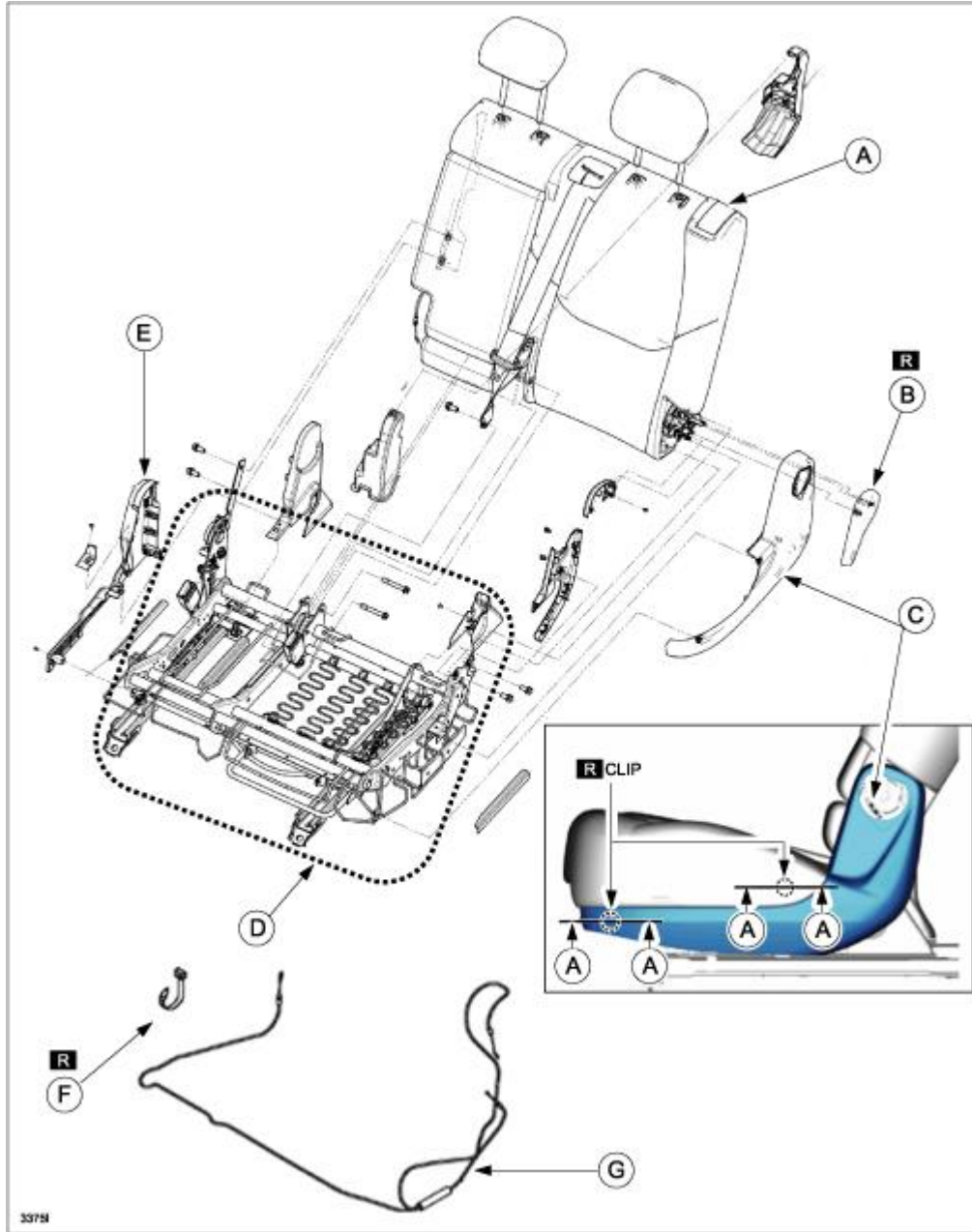

**CONSUMER NOTICE:** The information and instructions in this bulletin are intended for use by skilled technicians. Mazda technicians utilize the proper tools/equipment and take training to correctly and safely maintain Mazda vehicles. These instructions should not be performed by "do-it-yourselfers." Customers should not assume this bulletin applies to their vehicle or that their vehicle will develop the described concern. To determine if the information applies, customers should contact their nearest authorized Mazda dealership. Mazda North American Operations reserves the right to alter the specifications and contents of this bulletin without obligation or advance notice. All rights reserved. No part of this bulletin may be reproduced in any form or by any means, electronic or mechanical---including photocopying and recording and the use of any kind of information storage and retrieval system ---without permission in writing.

	<b>PART NAME</b>
A	Walk-In Lever
B	Recliner Lever Knob
C	Rear Door-Side, Second-Row, Seat Side Cover
D	Second-Row, Seat Cushion Frame
E	Rear Console-Side, Second-Row, Seat Side Cover
F	Band for Cable
G	Cable

**WARRANTY INFORMATION**

**NOTE:**

- This warranty information applies only to verified customer complaints on vehicles eligible for warranty repair.
- This repair will be covered under Mazda’s New Vehicle Limited Warranty term.
- Additional diagnostic time cannot be claimed for this repair.

Warranty Type	A
Symptom Code	64
Damage Code	9B
Part Number Main Cause	****-88-15Y*** / ****-88-10Y-**** (Enter the part number of the walk-in lever applicable to the vehicle in repair)
Quantity	1
Operation Number / Labor Hours:	Select and enter the appropriate operation number and hours from the following table according to the actual work performed.

**Labor and Operation Numbers and Hours:**

**CONSUMER NOTICE:** The information and instructions in this bulletin are intended for use by skilled technicians. Mazda technicians utilize the proper tools/equipment and take training to correctly and safely maintain Mazda vehicles. These instructions should not be performed by "do-it-yourselfers." Customers should not assume this bulletin applies to their vehicle or that their vehicle will develop the described concern. To determine if the information applies, customers should contact their nearest authorized Mazda dealership. Mazda North American Operations reserves the right to alter the specifications and contents of this bulletin without obligation or advance notice. All rights reserved. No part of this bulletin may be reproduced in any form or by any means, electronic or mechanical---including photocopying and recording and the use of any kind of information storage and retrieval system ---without permission in writing.

Operation Number	Hours	Operation: Walk-in lever, RR (Repair steps 1 - 2)	Operation: Internal mechanism of walk-in system, inspect (Repair steps 3 - 8)	Operation: Second row-seat frame, RR	Operation: Cable wire, RR
XXM89XRX	0.2	Performed	Did not perform	Did not perform	Did not perform
XXM89ARX	0.7	Performed	Performed	Did not perform	Did not perform
XXM89BRX	1.0	Performed	Performed	Did not perform	Performed
XXM89CRX	1.2	Performed	Performed	Performed	Performed or not

**CONSUMER NOTICE:** The information and instructions in this bulletin are intended for use by skilled technicians. Mazda technicians utilize the proper tools/equipment and take training to correctly and safely maintain Mazda vehicles. These instructions should not be performed by "do-it-yourselfers." Customers should not assume this bulletin applies to their vehicle or that their vehicle will develop the described concern. To determine if the information applies, customers should contact their nearest authorized Mazda dealership. Mazda North American Operations reserves the right to alter the specifications and contents of this bulletin without obligation or advance notice. All rights reserved. No part of this bulletin may be reproduced in any form or by any means, electronic or mechanical---including photocopying and recording and the use of any kind of information storage and retrieval system ---without permission in writing.