

Technical Service Bulletin

Mazda North American Operations
Irvine, CA 92618-2922



| | |
|---|--------------------------------|
| Subject: POOR AIR CONDITIONING PERFORMANCE AND OPERATION | Bulletin No.: 07-005/17 |
| | Last Issued: 05/12/2017 |

BULLETIN NOTES

This bulletin supersedes the previously issued bulletin(s) listed below. The changes are noted in Red text.

| | |
|----------------|-----------------|
| Previous TSBs: | Date(s) Issued: |
| 07-005/17 | 05/08/17 |

DESCRIPTION

APPLICABLE MODEL(S)/VINS

2016-2017 CX-9 vehicles with VINs lower than JM3TC*****135223 (produced before Jan. 6, 2017)

Some customers may complain that 1) the air conditioner is not cold enough or that 2) the cabin is cold, but the fan speed stays on high and there is noise coming from the blower motor.

The following may be the causes:

- 1)The A/C compressor ON/OFF control is not operating correctly, causing a problem with the air temperature control.
- 1)The air conditioner may not be cool enough due to inadequate amount of the refrigerant, due to leakage or overcharging.
- 2)The control of the amount of air blown is incorrect.

To eliminate these concerns, the front and rear climate control unit software has been modified to optimize the amount of air blown and the A/C compressor ON/OFF controls.

- The **rear climate control unit** software was modified on Dec. 1, 2016 (Beginning VIN: JM3TC**** **130572)
- The **front climate control unit** software was modified on Jan. 6, 2017 (Beginning VIN: JM3TC**** **135223)

Use the table below to determine if the customers vehicle is a Type A or a Type B vehicle, then follow the appropriate repair procedure below.

| Vehicle Type | Type A | Type B |
|--------------|--------|--------|
|--------------|--------|--------|

CONSUMER NOTICE: The information and instructions in this bulletin are intended for use by skilled technicians. Mazda technicians utilize the proper tools/equipment and take training to correctly and safely maintain Mazda vehicles. These instructions should not be performed by "do-it-yourselfers." Customers should not assume this bulletin applies to their vehicle or that their vehicle will develop the described concern. To determine if the information applies, customers should contact their nearest authorized Mazda dealership. Mazda North American Operations reserves the right to alter the specifications and contents of this bulletin without obligation or advance notice. All rights reserved. No part of this bulletin may be reproduced in any form or by any means, electronic or mechanical---including photocopying and recording and the use of any kind of information storage and retrieval system ---without permission in writing.

| | | |
|-------------------------------|--|--|
| VIN / Build Date Range | JM3TC**** **100001 - 130571 (Feb. 11, 2016 - Dec. 1, 2016) | JM3TC**** **130572 - 135222 (Feb. 11, 2016 - Jan. 6, 2017) |
|-------------------------------|--|--|

Customers having this concern should have their vehicle repaired using the following repair procedure.

REPAIR PROCEDURE

1. Verify the customer concern.

REPAIR PROCEDURES TO USE BY VEHICLE TYPE:

| Repair Procedure | Vehicle Type A | Vehicle Type B |
|---|----------------|----------------|
| Check refrigerant pressure. | YES | YES |
| Measure air conditioner output temperatures. | YES | YES |
| Repair refrigerant leak (IF ANY). | YES | YES |
| Refill with correct amount of refrigerant. | YES | YES |
| Replace front climate control unit with a modified one. | YES | YES |
| Replace rear climate control unit with a modified one. | YES | NO |

2. Inspect the refrigerant pressure according to the instructions on MGSS online (REFRIGERANT PRESSURE CHECK) and record the high and low pressure values.

3. Measure the air conditioner output temperature from the passenger's side center ventilator (A) and rear ventilator (B) outlets according to the instructions on MGSS online (REFRIGERANT SYSTEM PERFORMANCE TEST). Record the output temperature values with a dry-bulb thermometer (C) and the ambient temperature when it is measured.

CONSUMER NOTICE: The information and instructions in this bulletin are intended for use by skilled technicians. Mazda technicians utilize the proper tools/equipment and take training to correctly and safely maintain Mazda vehicles. These instructions should not be performed by "do-it-yourselfers." Customers should not assume this bulletin applies to their vehicle or that their vehicle will develop the described concern. To determine if the information applies, customers should contact their nearest authorized Mazda dealership. Mazda North American Operations reserves the right to alter the specifications and contents of this bulletin without obligation or advance notice. All rights reserved. No part of this bulletin may be reproduced in any form or by any means, electronic or mechanical---including photocopying and recording and the use of any kind of information storage and retrieval system ---without permission in writing.



4.If refrigerant leakage is a possibility, locate it using UV black light and repair it according to the instructions on MGSS online (REFRIGERANT CHARGING – Leak Test).

5.Recover refrigerant, evacuate the system and refill with correct amount of refrigerant (750g) according to the instructions on MGSS online (REFRIGERANT RECOVERY) and (REFRIGERANT CHARGING).

6.Replace the front climate control unit (A) with a modified one according to the instructions on MGSS online (FRONT CLIMATE CONTROL UNIT REMOVAL/INSTALLATION). Screws (B) and connector (C).

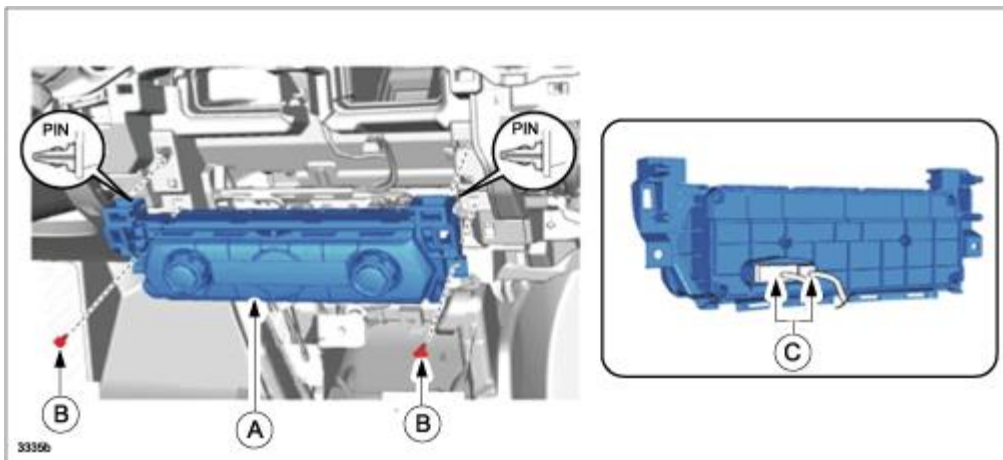

7.(FOR TYPE A VEHICLES ONLY) Replace the rear climate control unit (A) with a modified one according to the instructions on MGSS online (REAR CLIMATE CONTROL UNIT REMOVAL/INSTALLATION). Rear ventilator grille (B).

CONSUMER NOTICE: The information and instructions in this bulletin are intended for use by skilled technicians. Mazda technicians utilize the proper tools/equipment and take training to correctly and safely maintain Mazda vehicles. These instructions should not be performed by "do-it-yourselfers." Customers should not assume this bulletin applies to their vehicle or that their vehicle will develop the described concern. To determine if the information applies, customers should contact their nearest authorized Mazda dealership. Mazda North American Operations reserves the right to alter the specifications and contents of this bulletin without obligation or advance notice. All rights reserved. No part of this bulletin may be reproduced in any form or by any means, electronic or mechanical---including photocopying and recording and the use of any kind of information storage and retrieval system ---without permission in writing.

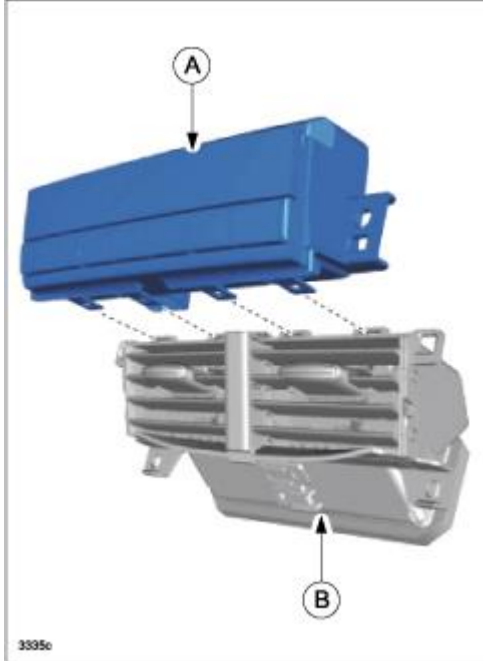

8. Verify the repair.

PARTS INFORMATION

| Parts Number | Description | Qty. | Notes |
|--------------|----------------------------|------|-------------------------|
| TK80-61-190F | Front Climate Control Unit | 1 | --- |
| TK80-61-325F | Rear Climate Control Unit | 1 | --- |
| 5555-CP-OIL | Compressor Oil (210ml) | 1 | Approx. 42ml per repair |
| 5555-FG-002 | A/C Refrigerant | 8 | (800g) |

WARRANTY INFORMATION

NOTE:

- This warranty information applies only to verified customer complaints on vehicles eligible for warranty repair.
- This repair will be covered under Mazda’s New Vehicle Limited Warranty term.
- Additional diagnostic time cannot be claimed for this repair.

| | |
|---------------|----|
| Warranty Type | A |
| Symptom Code | 59 |

CONSUMER NOTICE: The information and instructions in this bulletin are intended for use by skilled technicians. Mazda technicians utilize the proper tools/equipment and take training to correctly and safely maintain Mazda vehicles. These instructions should not be performed by "do-it-yourselfers." Customers should not assume this bulletin applies to their vehicle or that their vehicle will develop the described concern. To determine if the information applies, customers should contact their nearest authorized Mazda dealership. Mazda North American Operations reserves the right to alter the specifications and contents of this bulletin without obligation or advance notice. All rights reserved. No part of this bulletin may be reproduced in any form or by any means, electronic or mechanical---including photocopying and recording and the use of any kind of information storage and retrieval system ---without permission in writing.

| | |
|---------------------------------|--|
| Damage Code | 9W |
| Part Number Main Cause | TK80-61-190F |
| Quantity | 1 |
| Operation Number / Labor Hours: | <p style="text-align: center;">FOR VEHICLE TYPE A:</p> <p style="text-align: center;">Replace Both Front and Rear Climate Control Units. XXN3RXXR / 1.9 Hrs.</p> <p style="text-align: center;">(Includes Refrigerant Pressure Check, Refrigerant System Performance Test and Gas Charging)</p> <p style="text-align: center;">FOR VEHICLE TYPE B:</p> <p style="text-align: center;">Replace only Front Climate Control Unit. XXN3SARX /1.8 Hrs.</p> <p style="text-align: center;">(Includes Refrigerant Pressure Check, Refrigerant System Performance Test and Gas Charging)</p> <p>If refrigerant leak was found and repaired, claim the repair only on a separate problem number, the associated part along with the labor operation for that part as listed in Warranty Wizard. Freon, compressor oil, evacuation and charge operations are included in the TSB labor operations.</p> |

NOTE:

- Claim the compressor oil using 5555-CP-OIL, which will reimburse for 1/5 of the can (approx. 42ml).

Problem Cause / Remedy Text:

Enter the following test results when submitting the claim.

- Refrigerant pressure high and low
- Output temperature from front vent
- Output temperature from rear vent
- Ambient temperature when tested

CONSUMER NOTICE: The information and instructions in this bulletin are intended for use by skilled technicians. Mazda technicians utilize the proper tools/equipment and take training to correctly and safely maintain Mazda vehicles. These instructions should not be performed by "do-it-yourselfers." Customers should not assume this bulletin applies to their vehicle or that their vehicle will develop the described concern. To determine if the information applies, customers should contact their nearest authorized Mazda dealership. Mazda North American Operations reserves the right to alter the specifications and contents of this bulletin without obligation or advance notice. All rights reserved. No part of this bulletin may be reproduced in any form or by any means, electronic or mechanical---including photocopying and recording and the use of any kind of information storage and retrieval system ---without permission in writing.