

MODEL: Karma Revero

DATE: July 2017

TITLE: Baseline BL1021 Release

Revised August

PRIORITY: All Revero

APPLICABILITY: MY17 and MY18 Revero

MARKET REGION: North America

PURPOSE: This document will be used as a reference guide for technicians to update a vehicle to Baseline 1021

Flash reprogramming allows the control module software to be updated without replacement of the control module hardware. This flash calibration update for the Revero and specific control modules is released as field update procedure as described in the respective service bulletin.

Software and firmware updates will be scheduled as part of Karma Automotive continuous improvements process.

The Karma Sync tool will allow the technician to display the current software identification and cross reference them to any that will be included in the latest updates.

Central Infotainment Unit flashing will occur over the air, TSS is required to be notified prior to this step.

REQUIREMENT: There is a component of this Baseline release which will be performed Over the Air. this will require creating a technical services support (TSS) case as soon as the vehicle arrives at the dealer. Please schedule this baseline install and begin the action early in the workday to allow sufficient time to contact and activate this over the air update through the TSS group.

⚠ NOTICE! ⚠

The vehicle should have the High Voltage battery charged. If the State of Charge is 15% or less, when placed in Ready Mode, the vehicle generator may turn on at any time during the flash process. Therefore we recommend the state of charge is 25% or greater before beginning the flash procedure, or five (5) miles of EV range.

⚠ NOTICE! ⚠

Have a 12V power supply available to use on every Revero during flashing of modules, there are no exceptions to this. Vehicle 12V battery voltage must be maintained greater than 12.5V while flashing the control modules.

MODEL: Karma Revero

DATE: July 2017

TITLE: Baseline BL1021 Release

Revised August

WARNING!

DO NOT ALLOW LAPTOP TO GO INTO SLEEP OR SCREEN SAVER MODE DURING THIS PROCESS. TURN OFF SCREEN SAVER IF NECESSARY AND ENSURE THE LAPTOP STAYS AWAKE. THE LAPTOP MUST BE PLUGGED INTO A STABLE POWER SOURCE DURING THE PROCESS. IF THE VEHICLE GOES INTO SLEEP MODE WHILE AN ECU IS BEING PROGRAMMED; THE REPROGRAMMING MAY BE UNSUCCESSFUL AND MAY CAUSE DAMAGE TO THE ECU.

The following vehicles are subject to this bulletin.

Vehicle Identification Number	
50GK41SA3HA000012	50GK41SA0JA000023
50GK41SA7HA000014	50GK41SA2JA000024
50GK41SA0HA000016	50GK41SA4JA000025
50GK41SA4HA000018	50GK41SA6JA000026
50GK41SA6HA000019	50GK41SA9JA000019
50GK41SA2HA000020	50GK41SA5JA000020
50GK41SA4HA000021	50GK41SA8JA000027
50GK41SA6HA000022	50GK41SA2JA000007
50GK41SA8HA000023	50GK41SAXJA000028
50GK41SAXHA000024	50GK41SA1JA000029
50GK41SA4JA000011	50GK41SA8JA000030
50GK41SA6JA000012	50GK41SAXJA000031
50GK41SA8JA000013	50GK41SA1JA000032
50GK41SAXJA000014	50GK41SA3JA000033
50GK41SA1JA000015	50GK41SA5JA000034
50GK41SA3JA000016	50GK41SA7JA000035
50GK41SA5JA000017	50GK41SA9JA000036
50GK41SA7JA000021	50GK41SA2JA000010
50GK41SA9JA000022	50GK41SA0JA000040

Karma Automotive Bulletins and service documents are intended for use by experienced and trained Technicians. If you lack the skills, tools, equipment and a suitable workshop for any procedure described in this document, we suggest you leave such repairs to a Karma retailer and service provider. See your service provider for advice on whether your vehicle may benefit from the information contained within this document. The information contained in the Karma Bulletin is accurate at the date of publication. However, Karma Automotive regularly updates technical information. Please check with your Karma Automotive Retailer and Karma Automotive service provider that the bulletin you intend to use contains the latest available information.

MODEL: Karma Revero

DATE: July 2017

TITLE: Baseline BL1021 Release

Revised August

BL1021 updates provide the following:

Advanced Driver Assistance System (ADAS): Calibration function in Karma Sync available. The target required (special tool number is C161197900100) for use in calibration is available as well

ECM: Enhanced (OBD) diagnostics

Lane Departure Warning (LDW): Enhancements introduced

BECM (HV Battery): Functional enhancements introduced. Diagnostics action is improved and State of Charge reporting also enhanced

Central Infotainment Unit (CIU): Enhancements to the diagnostics strategy introduced. Multiple enhancements to the audio function enabled. After phone call ending, audio system reaction and performance is also enhanced. Settings menu behavior is improved

- **12V maintenance:** this function is also improved
- **Firmware Over-the-Air (FOTA):** Firmware over the air capabilities have been enhanced. including French text display
- **Navigation:** Multiple functional improvements added, route finding is enhanced
- **Touch panel interface:** Display, function, and response has been improved. HVAC- display function improved. Displayed message logic is improved. French text display is improved

Instrument panel (DIS): Improvements to the interface and multiple functional display enhancements

Hybrid Control Unit (HCU): Charging functionality improved. Diagnostics enhanced. Generator function in warm conditions also improved

HVAC: Improved cabin airflow action during charging. This is a change in air flow strategy to mitigate window condensation during charging

Rainlight Sensor (RLS): To prevent rapid brightness changes in the display panels, the rain light sensor performance has been refined

VCM-S: Enhancements to personalization and function for vehicle locking/ unlocking behavior. Easy Entry and Exit performance improvement

VCM-B: Improved diagnostics and system function

Karma Automotive Bulletins and service documents are intended for use by experienced and trained Technicians. If you lack the skills, tools, equipment and a suitable workshop for any procedure described in this document, we suggest you leave such repairs to a Karma retailer and service provider. See your service provider for advice on whether your vehicle may benefit from the information contained within this document. The information contained in the Karma Bulletin is accurate at the date of publication. However, Karma Automotive regularly updates technical information. Please check with your Karma Automotive Retailer and Karma Automotive service provider that the bulletin you intend to use contains the latest available information.

MODEL: Karma Revero

DATE: July 2017

TITLE: Baseline BL1021 Release

Revised August

Record the Software identifications displayed on Karma Sync workshop tester. This is seen when you select the ECU's to be flashed. **Note: the CIU software will be updated over the air with assistance from TSS for this release. The CIU software ID is verified from the TPI, not Karma Sync.**

Action	ECU	Target Software	Current Software
<input type="checkbox"/>	Power Inverter Module for Generator	0301-06-30	0301-06-29
<input checked="" type="checkbox"/>	Accessory Power Module	0311-01-02	0311-01-02
<input type="checkbox"/>	Advanced Driver Assistance System	0381-00-38	0381-00-28
<input checked="" type="checkbox"/>	Engine Control Module	0121-09-01	0121-09-01
<input type="checkbox"/>	Vehicle Control Module Security	0411-01-11	0411-01-07
<input type="checkbox"/>	Vehicle Control Module Body	0401-00-24	0401-00-22
<input type="checkbox"/>	Battery Energy Control Module	0156-04-39	0156-04-36
<input type="checkbox"/>	Hybrid Control Unit	0111-0C-54	0111-0C-49
<input type="checkbox"/>	Heat/Ventilation Air Conditioning	0162-02-42	0162-02-40
<input type="checkbox"/>	Memory Seat Module	0441-02-07	0441-02-06

The above is a screen shot from the Karma Sync showing the software IDs and current level identifications. Please note the Engine control module target name will be the same on this list. Identification of the Engine Control Module will be found in module identification- the “Calibration Data Module Identifier”, as shown below.

Control Module	Name	Value
Engine Control Module	Calibration Data Module Identifier	01270901
Engine Control Module	Diagnostic Data Identifier (2):Data Record:Diagnostic Data ID Digit 1 (System Code)	11
Engine Control Module	Diagnostic Data Identifier (2):Data Record:Diagnostic Data ID Digit 2 (Version Code)	0
Engine Control Module	ECU Diagnostic Address:Data Record:ECU Diagnostic Address	17
Engine Control Module	Karma FMSDS Item Number:Data Record:Hardware Part Number	01230300
Engine Control Module	Manufacturers Enable Counter (2):Data Record:Manufacturers Enable Counter	0
Engine Control Module	Software Module Identifier	01210901
Engine Control Module	Vehicle Identification Number	50GK41SA0JA000023

Karma Automotive Bulletins and service documents are intended for use by experienced and trained Technicians. If you lack the skills, tools, equipment and a suitable workshop for any procedure described in this document, we suggest you leave such repairs to a Karma retailer and service provider. See your service provider for advice on whether your vehicle may benefit from the information contained within this document. The information contained in the Karma Bulletin is accurate at the date of publication. However, Karma Automotive regularly updates technical information. Please check with your Karma Automotive Retailer and Karma Automotive service provider that the bulletin you intend to use contains the latest available information.



MODEL: Karma Revero

DATE: July 2017

TITLE: Baseline BL1021 Release

Revised August

The target software should be as indicated in the table below.

Record the software IDs displayed on the Karma Sync workshop tester. before you begin.

Control Module Name	Software Version ID after BL1021 update	Software ID as received before BL1021 Update (enter ID displayed on scan tool below)
Accessory Power Module	0311-01-02	
Advance Driver Assistance System (ADAS)	0381-00-38	
Battery Energy Control Module (BECM)	0156-04-39	
Engine Control Module (ECM) (Cal ID)	0127-09-02	
Heat/Ventilation Air Conditioning (HVAC)	162-02-42	
Hybrid Control Unit (HCU)	0111-0C-54	
Memory Seat Module (MSM)	0441-02-07	
Power Inverter Module for Generator	0301-06-30	
Vehicle Control Module - Security (VCM-S)	0411-01-11	
Vehicle Control Module - Body (VCM-B)	0401-00-24	
Central Infotainment Unit (CIU)	17.11.16.2	

NOTE: The CIU software will be updated over the air with assistance from TSS for this release. The software version ID is found in the TPI, go to; Settings > Vehicle > About

MODEL: Karma Revero

DATE: July 2017

TITLE: Baseline BL1021 Release

Revised August

Using the vehicle settings, set the Accessory Delay to fifteen time (15 minutes) available for this update in the My Karma settings. Ensure the Accessory Delay is set back to the customer desired setting

1. Launch the Karma Sync application or close and relaunch if already open
2. Upon launch of the scan tool you may be prompted to enter user credentials
3. When a software update is available an update dialog box should appear with the new software package (fig.1).

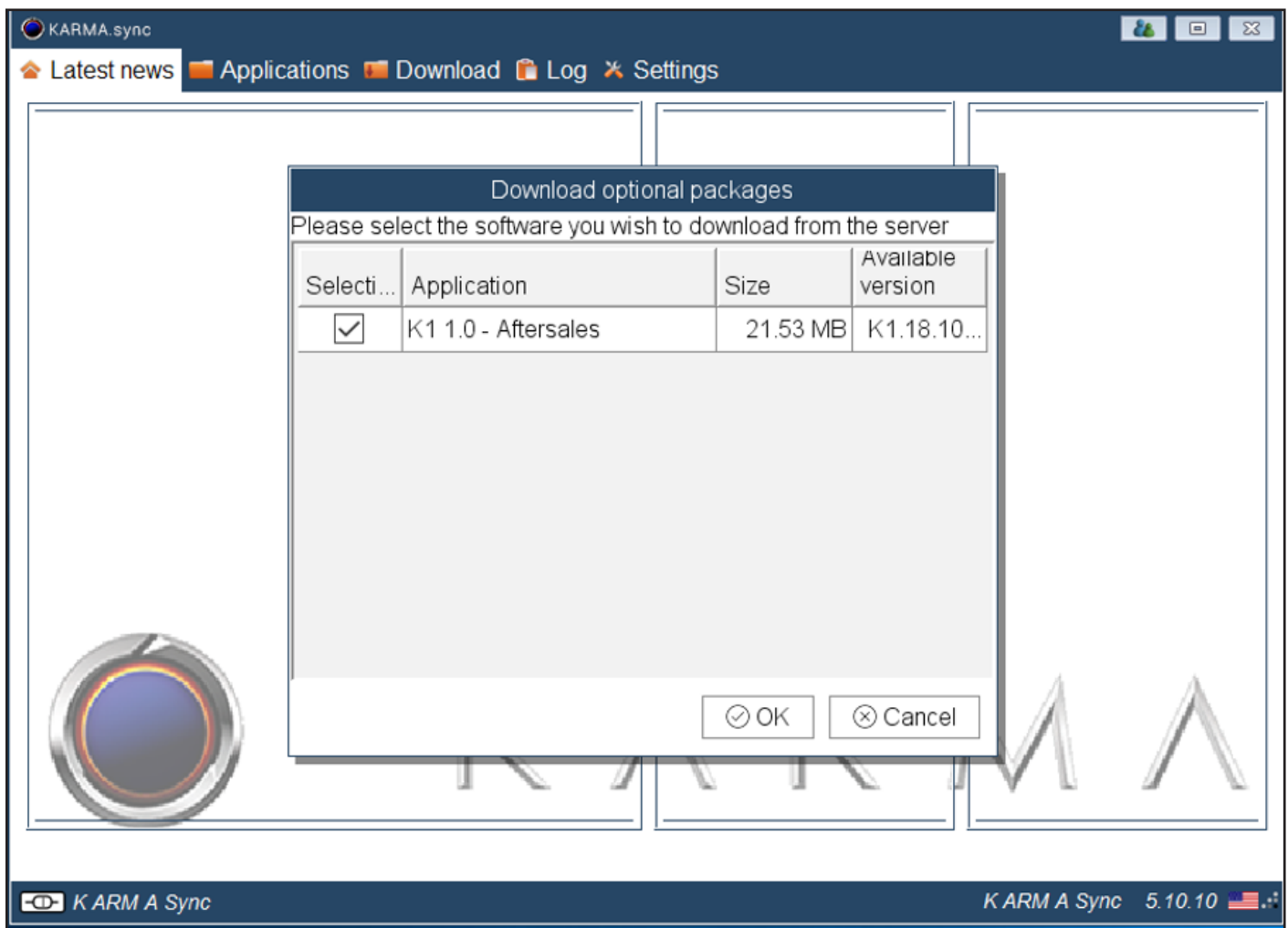

fig.1

4. Click "Ok" to install. (fig. 1)

Karma Automotive Bulletins and service documents are intended for use by experienced and trained Technicians. If you lack the skills, tools, equipment and a suitable workshop for any procedure described in this document, we suggest you leave such repairs to a Karma retailer and service provider. See your service provider for advice on whether your vehicle may benefit from the information contained within this document. The information contained in the Karma Bulletin is accurate at the date of publication. However, Karma Automotive regularly updates technical information. Please check with your Karma Automotive Retailer and Karma Automotive service provider that the bulletin you intend to use contains the latest available information.

MODEL: Karma Revero

DATE: July 2017

TITLE: Baseline BL1021 Release

Revised August

The package will then download (fig.2a).

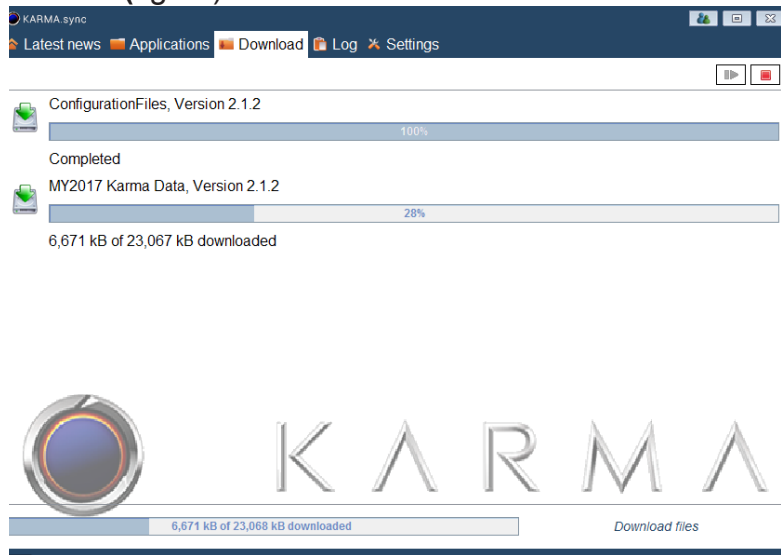

fig.2a

5. When download is complete, follow the on screen prompt, to allow the Software to update on the next restart (fig.2b). Doing this restart is a complete closing of Karma SYNC and relaunching as the to restart the program.

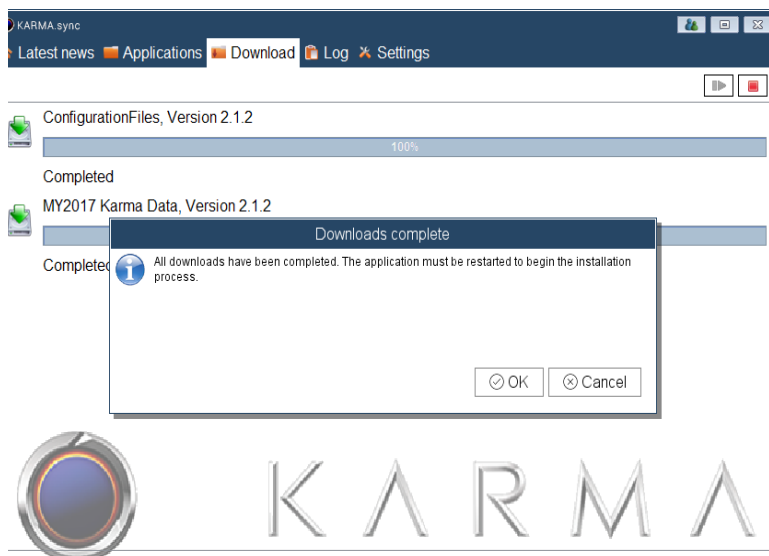

fig.2b

Karma Automotive Bulletins and service documents are intended for use by experienced and trained Technicians. If you lack the skills, tools, equipment and a suitable workshop for any procedure described in this document, we suggest you leave such repairs to a Karma retailer and service provider. See your service provider for advice on whether your vehicle may benefit from the information contained within this document. The information contained in the Karma Bulletin is accurate at the date of publication. However, Karma Automotive regularly updates technical information. Please check with your Karma Automotive Retailer and Karma Automotive service provider that the bulletin you intend to use contains the latest available information.

MODEL: Karma Revero

DATE: July 2017

TITLE: Baseline BL1021 Release

Revised August

Restart Scan Tool: The dialog box should open automatically-

If the dialog box does not open automatically to download the new software proceed to add software as shown The tool bar will have a Karma Sync icon, hover over it (fig. 3a), right-click, proceed to “add software” as in (fig. 3b). Once complete proceed with the remainder of this bulletin.

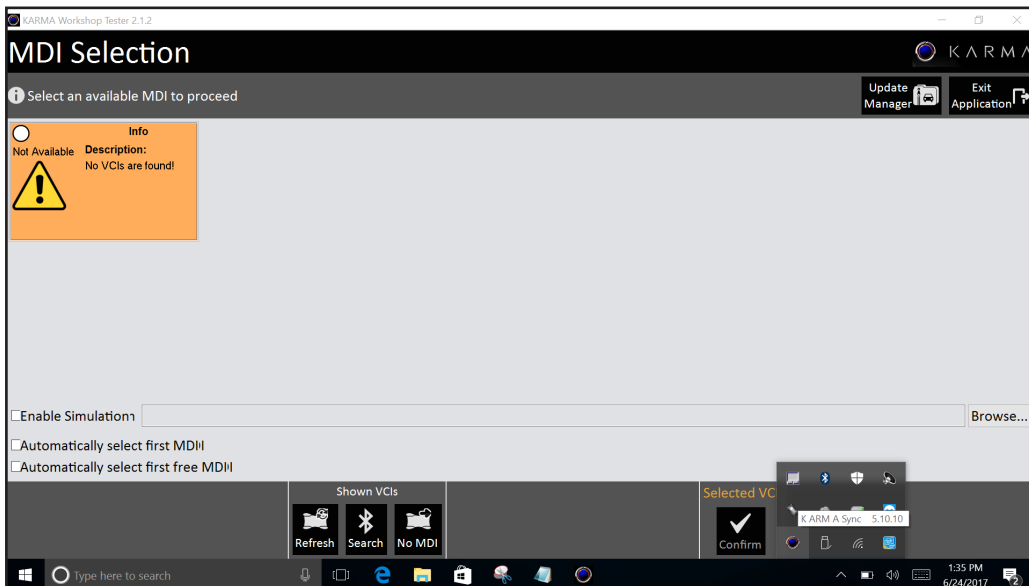

fig.3a

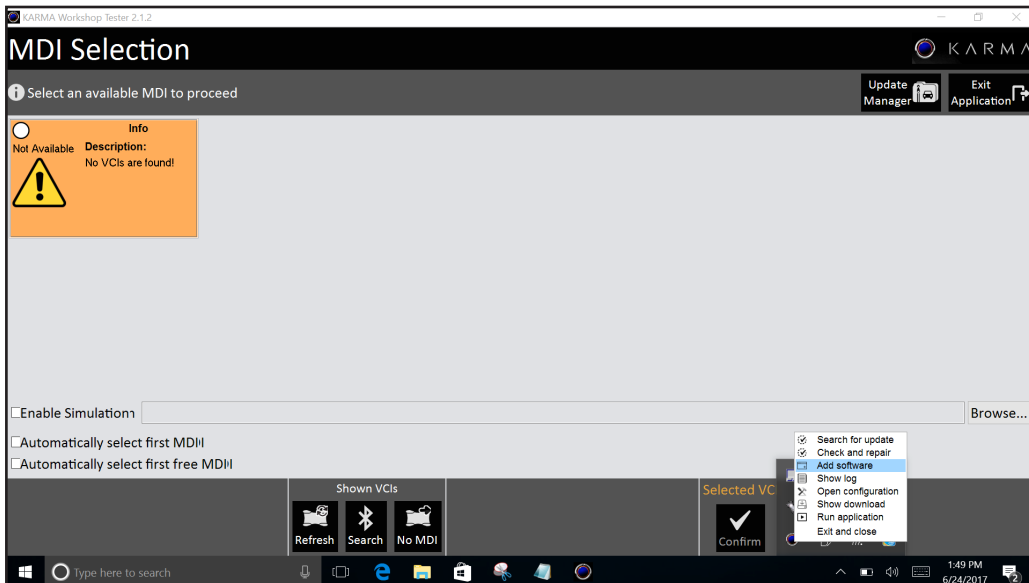

fig.3b

Karma Automotive Bulletins and service documents are intended for use by experienced and trained Technicians. If you lack the skills, tools, equipment and a suitable workshop for any procedure described in this document, we suggest you leave such repairs to a Karma retailer and service provider. See your service provider for advice on whether your vehicle may benefit from the information contained within this document. The information contained in the Karma Bulletin is accurate at the date of publication. However, Karma Automotive regularly updates technical information. Please check with your Karma Automotive Retailer and Karma Automotive service provider that the bulletin you intend to use contains the latest available information.

MODEL: Karma Revero

DATE: July 2017

TITLE: Baseline BL1021 Release

Revised August

6. Open the Karma Sync application again.
The “Confirm Deliverable Update - K1-18-1021.RC1” box should appear, click “Yes” (fig.4a)

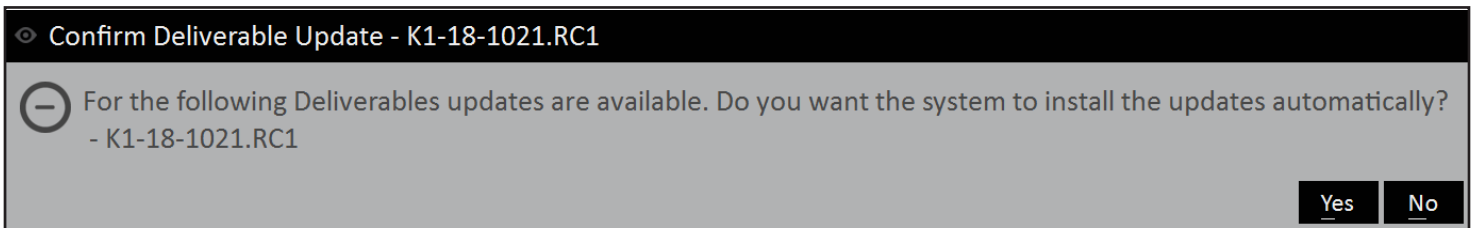

fig.4a

A progress screen will pop up after (fig.4b)



fig.4b

MODEL: Karma Revero

DATE: July 2017

TITLE: Baseline BL1021 Release

Revised August

7. Verify the package installed by clicking on update manager (fig.4c)

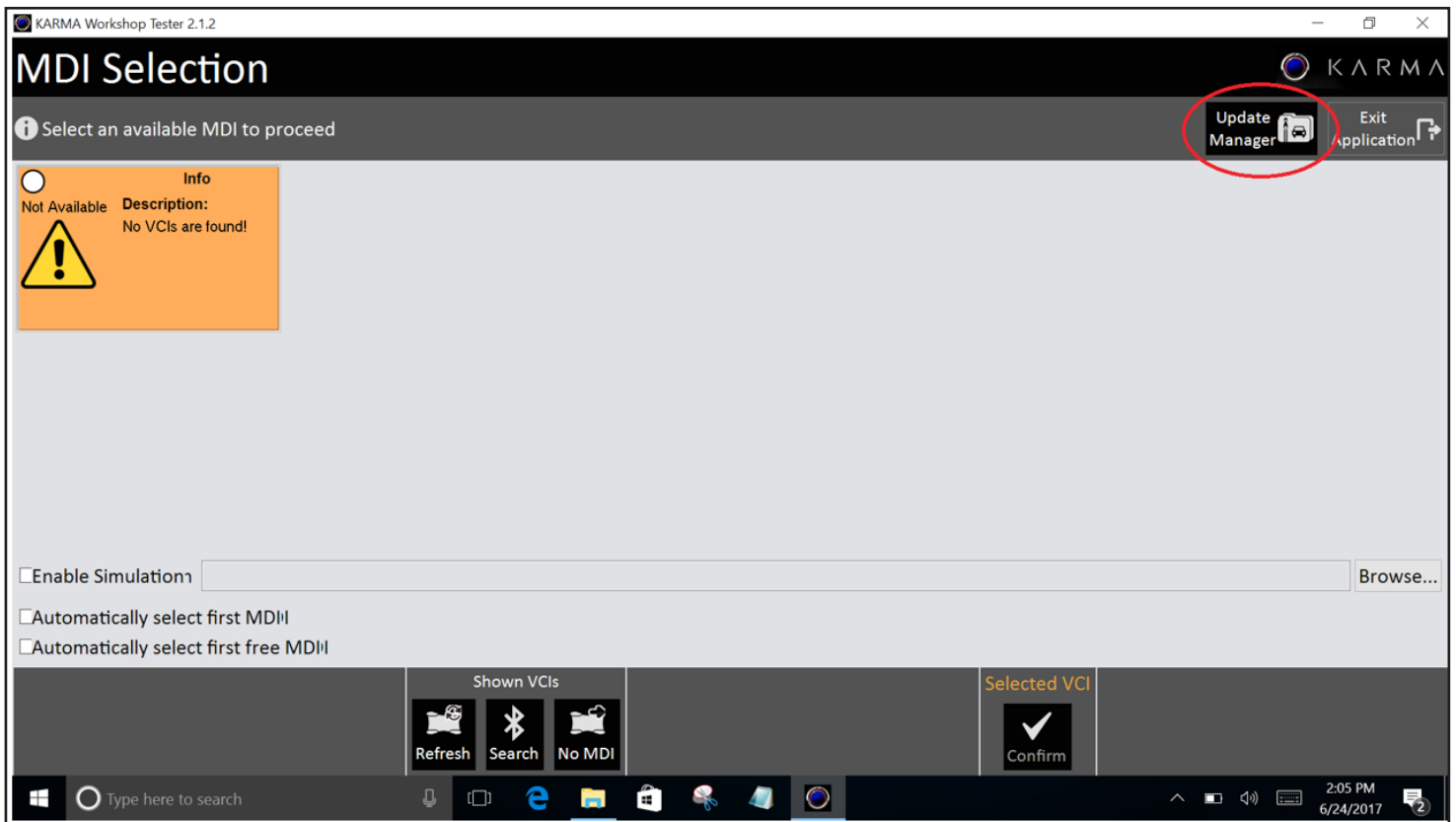

fig.4c

Karma Automotive Bulletins and service documents are intended for use by experienced and trained Technicians. If you lack the skills, tools, equipment and a suitable workshop for any procedure described in this document, we suggest you leave such repairs to a Karma retailer and service provider. See your service provider for advice on whether your vehicle may benefit from the information contained within this document. The information contained in the Karma Bulletin is accurate at the date of publication. However, Karma Automotive regularly updates technical information. Please check with your Karma Automotive Retailer and Karma Automotive service provider that the bulletin you intend to use contains the latest available information.

MODEL: Karma Revero

DATE: July 2017

TITLE: Baseline BL1021 Release

Revised August

8. Verify the package is installed successfully by verifying that “K1-18-1021.RC1” is displayed in the Update Manager (fig.5)

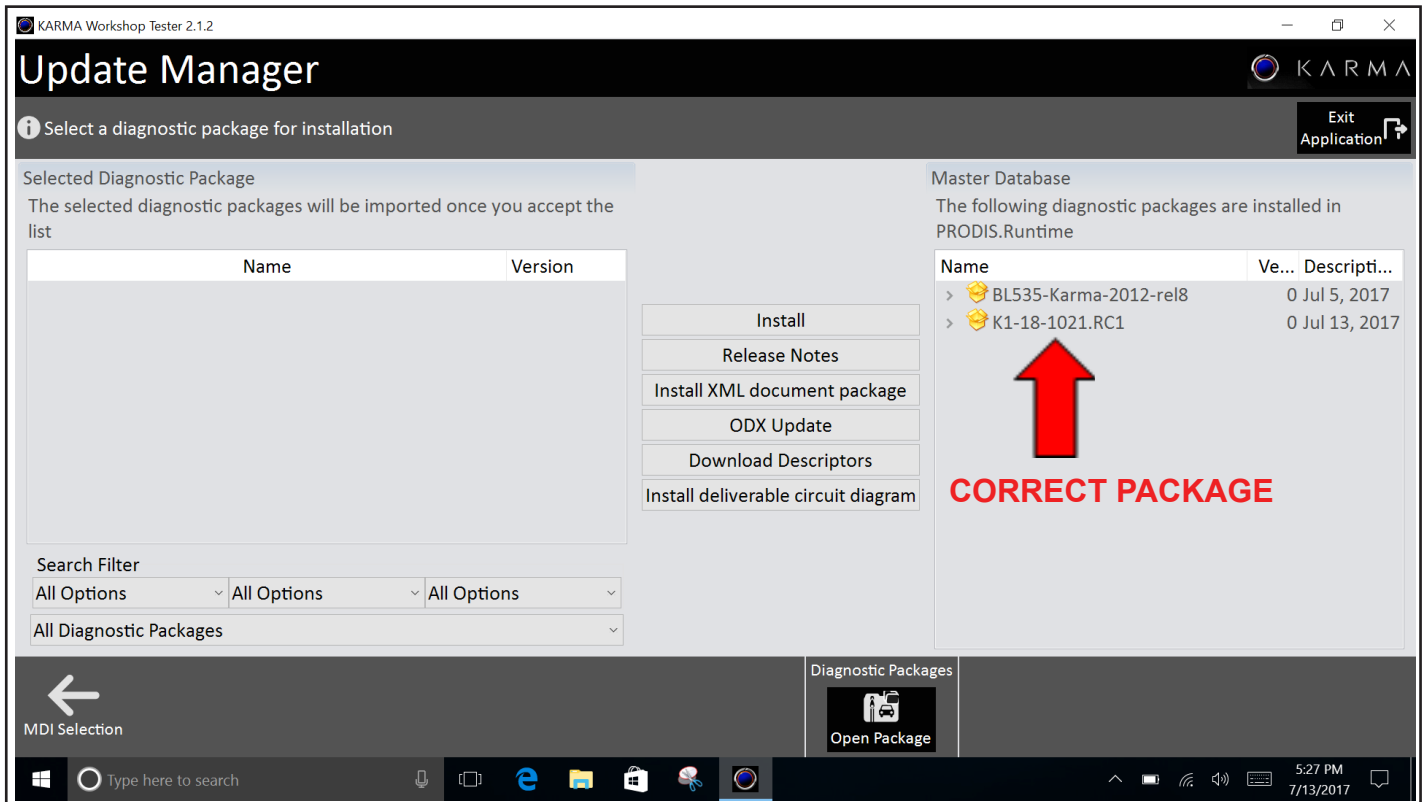

fig.5

Karma Automotive Bulletins and service documents are intended for use by experienced and trained Technicians. If you lack the skills, tools, equipment and a suitable workshop for any procedure described in this document, we suggest you leave such repairs to a Karma retailer and service provider. See your service provider for advice on whether your vehicle may benefit from the information contained within this document. The information contained in the Karma Bulletin is accurate at the date of publication. However, Karma Automotive regularly updates technical information. Please check with your Karma Automotive Retailer and Karma Automotive service provider that the bulletin you intend to use contains the latest available information.

MODEL: Karma Revero

DATE: July 2017

TITLE: Baseline BL1021 Release

Revised August

- Place vehicle in Ready Mode
- 1. Enter the Vehicle Diagnosis menu (fig.6a)

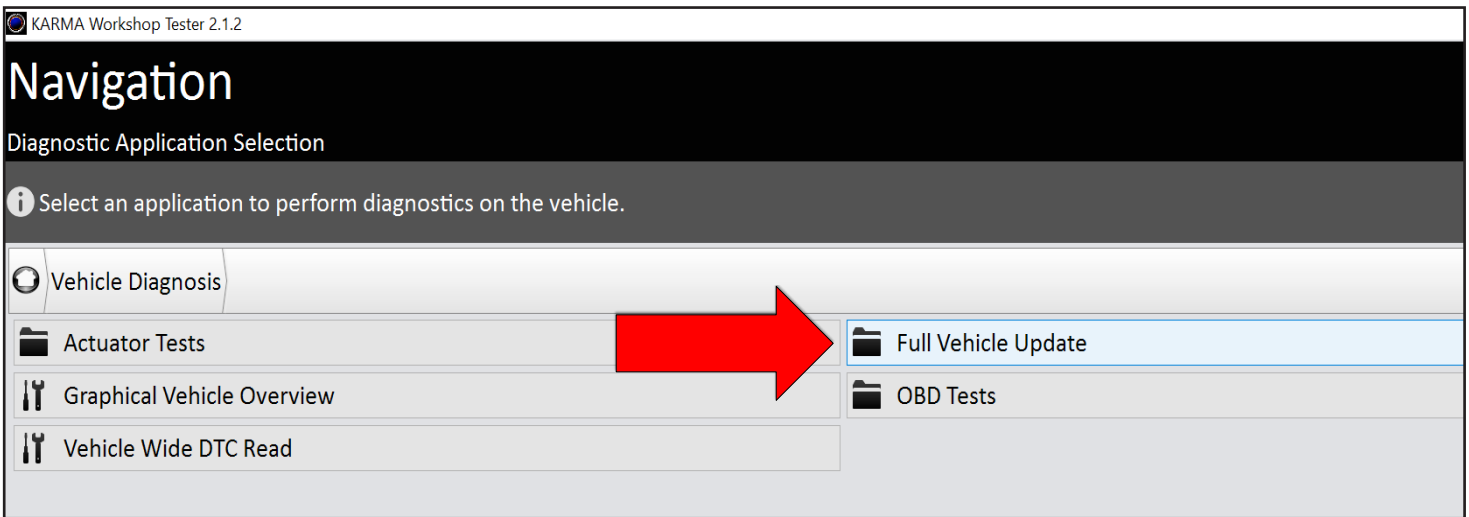

fig.6a

- 2. Proceed to Full Vehicle Update
- Click on "K1-18-1021.RC1" (fig. 6b)

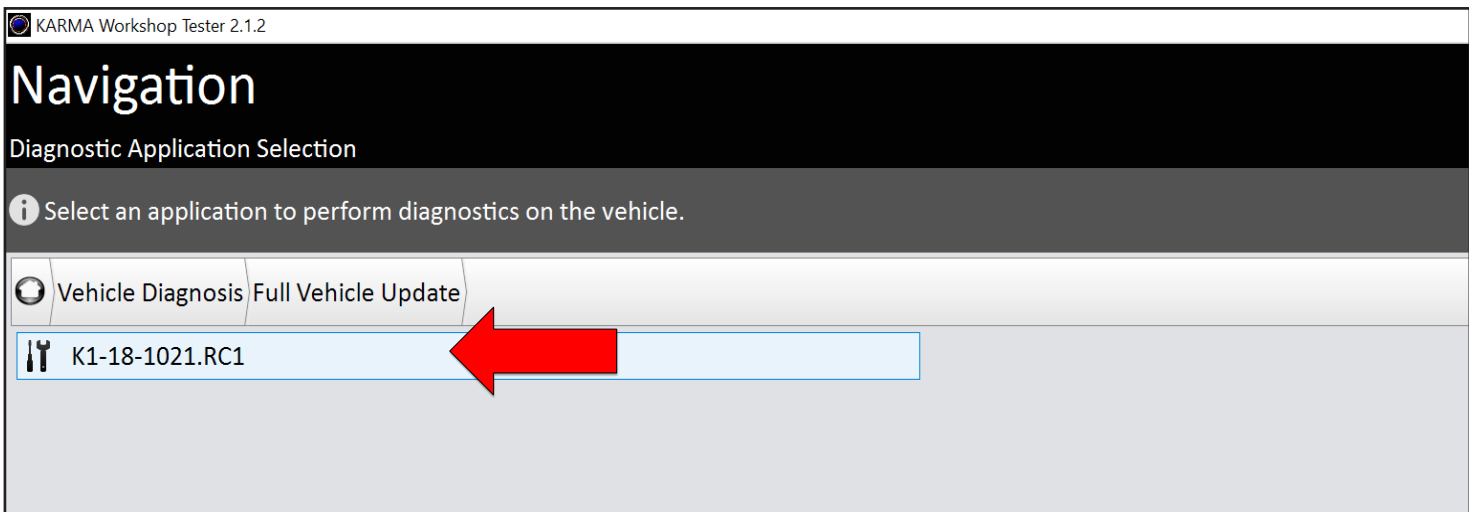

fig.6b

Karma Automotive Bulletins and service documents are intended for use by experienced and trained Technicians. If you lack the skills, tools, equipment and a suitable workshop for any procedure described in this document, we suggest you leave such repairs to a Karma retailer and service provider. See your service provider for advice on whether your vehicle may benefit from the information contained within this document. The information contained in the Karma Bulletin is accurate at the date of publication. However, Karma Automotive regularly updates technical information. Please check with your Karma Automotive Retailer and Karma Automotive service provider that the bulletin you intend to use contains the latest available information.

MODEL: Karma Revero

DATE: July 2017

TITLE: Baseline BL1021 Release

Revised August

3. The flash information will be populated

-If a pop up opens stating the “OBCM failed to communicate;” disregard this message

Click **DESELECT ALL** (fig. 7a)

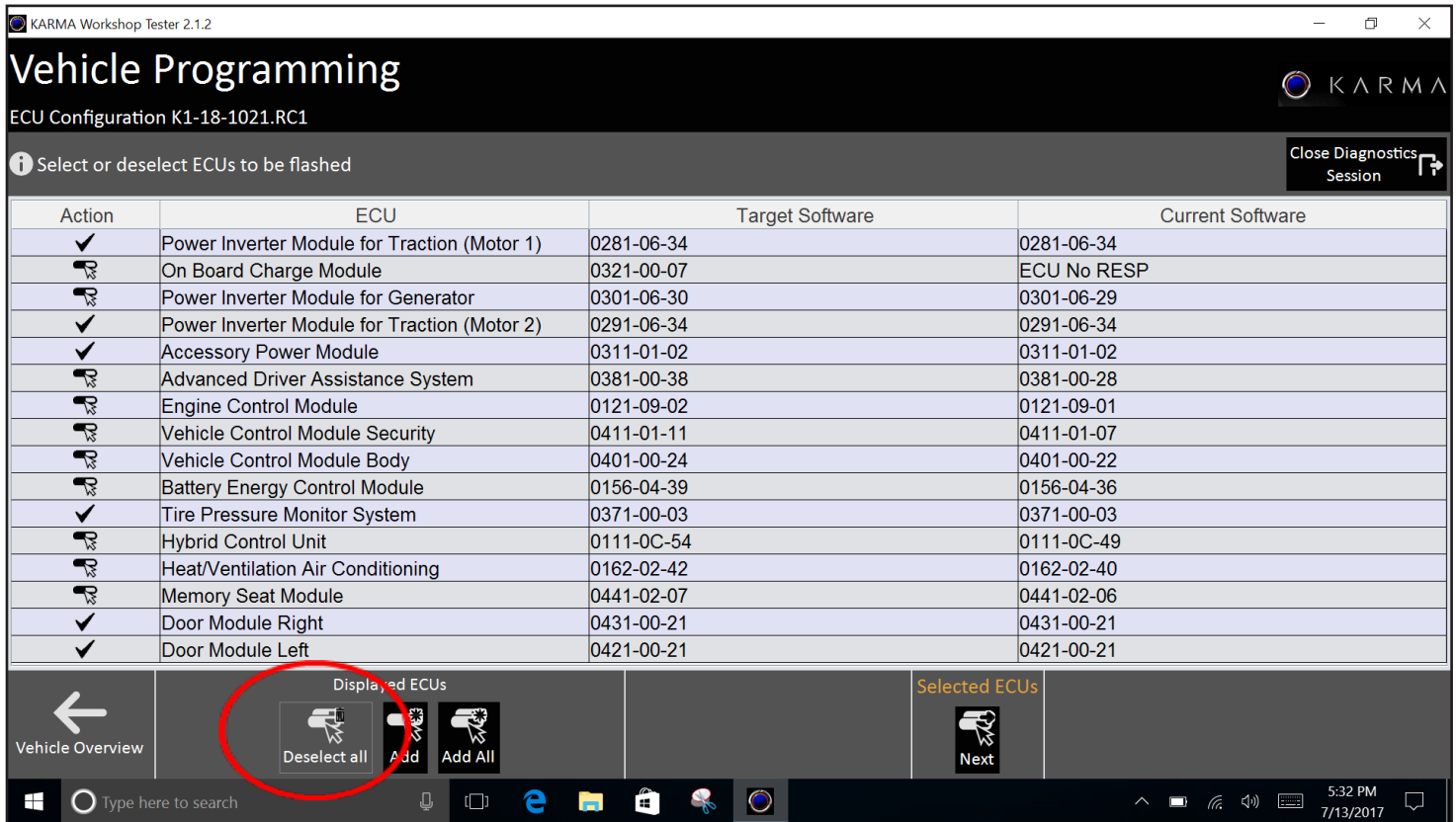

fig.7a

Karma Automotive Bulletins and service documents are intended for use by experienced and trained Technicians. If you lack the skills, tools, equipment and a suitable workshop for any procedure described in this document, we suggest you leave such repairs to a Karma retailer and service provider. See your service provider for advice on whether your vehicle may benefit from the information contained within this document. The information contained in the Karma Bulletin is accurate at the date of publication. However, Karma Automotive regularly updates technical information. Please check with your Karma Automotive Retailer and Karma Automotive service provider that the bulletin you intend to use contains the latest available information.

MODEL: Karma Revero

DATE: July 2017

TITLE: Baseline BL1021 Release

Revised August

4. Click and highlight Engine Control Module; perform the following steps
 - a. Click "Add" button
 - b. Click "Next" (as shown below in fig.7b)

KARMA Workshop Tester 2.1.2

Vehicle Programming

ECU Configuration K1-18-1021.RC1

Select or deselect ECUs to be flashed

Action	ECU	Target Software	Current Software
<input type="checkbox"/>	Power Inverter Module for Traction (Motor 1)	0281-06-34	0281-06-34
<input type="checkbox"/>	On Board Charge Module	0321-00-07	ECU No RESP
<input type="checkbox"/>	Power Inverter Module for Generator	0301-06-30	0301-06-29
<input type="checkbox"/>	Power Inverter Module for Traction (Motor 2)	0291-06-34	0291-06-34
<input type="checkbox"/>	Accessory Power Module	0311-01-02	0311-01-02
<input type="checkbox"/>	Advanced Driver Assistance System	0381-00-38	0381-00-28
<input checked="" type="checkbox"/>	Engine Control Module	0121-09-02	0121-09-01
<input type="checkbox"/>	Vehicle Control Module Security	0411-01-11	0411-01-07
<input type="checkbox"/>	Vehicle Control Module Body	0401-00-24	0401-00-22
<input type="checkbox"/>	Battery Energy Control Module	0156-04-39	0156-04-36
<input type="checkbox"/>	Tire Pressure Monitor System	0371-00-03	0371-00-03
<input type="checkbox"/>	Hybrid Control Unit	0111-0C-54	0111-0C-49
<input type="checkbox"/>	Heat/Ventilation Air Conditioning	0162-02-42	0162-02-40
<input type="checkbox"/>	Memory Seat Module	0441-02-07	0441-02-06
<input type="checkbox"/>	Door Module Right	0431-00-21	0431-00-21
<input type="checkbox"/>	Door Module Left	0421-00-21	0421-00-21

Close Diagnostics Session

Vehicle Overview

Displayed ECUs

Deselect all Add Add All

Selected ECUs

Next

fig.7b

Karma Automotive Bulletins and service documents are intended for use by experienced and trained Technicians. If you lack the skills, tools, equipment and a suitable workshop for any procedure described in this document, we suggest you leave such repairs to a Karma retailer and service provider. See your service provider for advice on whether your vehicle may benefit from the information contained within this document. The information contained in the Karma Bulletin is accurate at the date of publication. However, Karma Automotive regularly updates technical information. Please check with your Karma Automotive Retailer and Karma Automotive service provider that the bulletin you intend to use contains the latest available information.

MODEL: Karma Revero

DATE: July 2017

TITLE: Baseline BL1021 Release

Revised August

5. Follow the prompts and ensure that a suitable 12V power supply is connected to the vehicle. and click continue as per (fig. 8a).

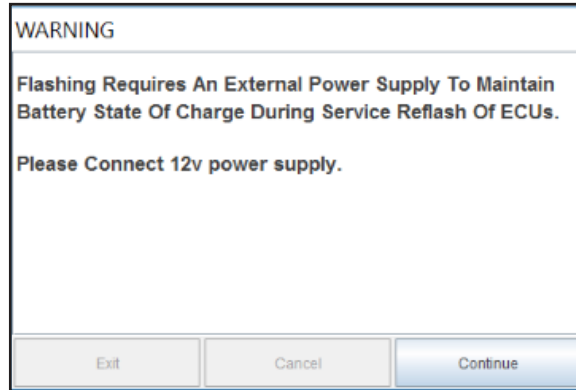

fig.8a

Below is an example of a suitable and recommended power supply (fig.8b)



fig.8b

Karma Automotive Bulletins and service documents are intended for use by experienced and trained Technicians. If you lack the skills, tools, equipment and a suitable workshop for any procedure described in this document, we suggest you leave such repairs to a Karma retailer and service provider. See your service provider for advice on whether your vehicle may benefit from the information contained within this document. The information contained in the Karma Bulletin is accurate at the date of publication. However, Karma Automotive regularly updates technical information. Please check with your Karma Automotive Retailer and Karma Automotive service provider that the bulletin you intend to use contains the latest available information.

MODEL: Karma Revero

DATE: July 2017

TITLE: Baseline BL1021 Release

Revised August

6. When the prompt is displayed the car has already been shut down for you, cycle back to Accessory Mode only! (fig.9a)

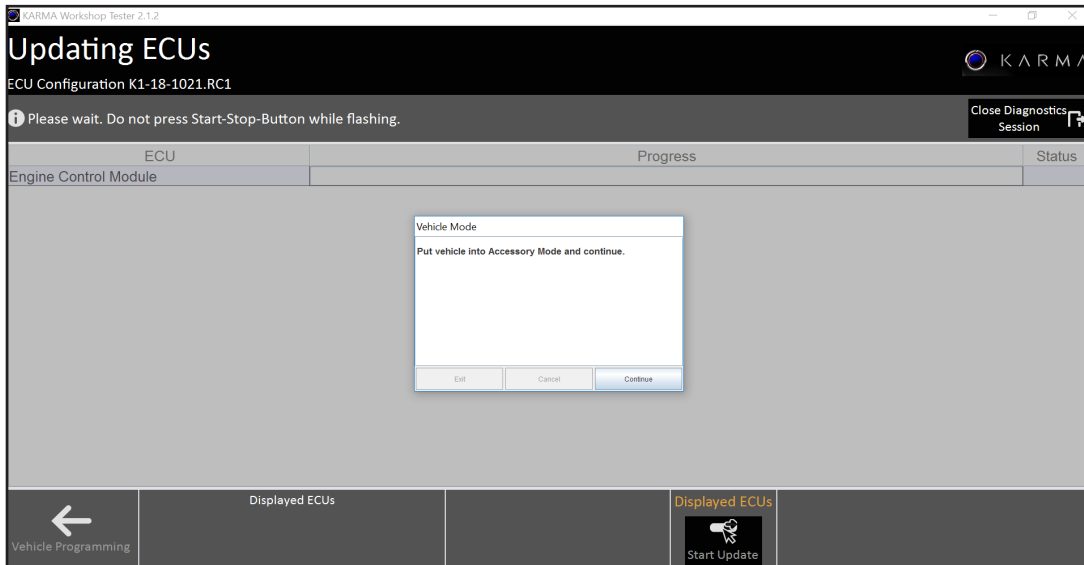

fig.9a

Click “Start Update”, the update will then begin. (fig.9b)

Do not interrupt the update until you see a green check mark or a red “x”.

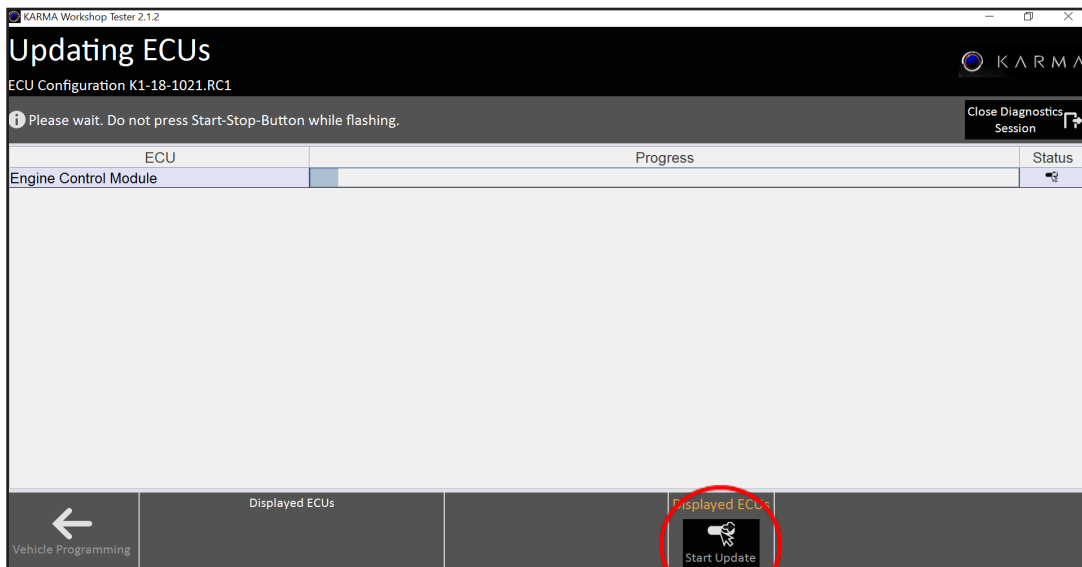

fig.9b

Karma Automotive Bulletins and service documents are intended for use by experienced and trained Technicians. If you lack the skills, tools, equipment and a suitable workshop for any procedure described in this document, we suggest you leave such repairs to a Karma retailer and service provider. See your service provider for advice on whether your vehicle may benefit from the information contained within this document. The information contained in the Karma Bulletin is accurate at the date of publication. However, Karma Automotive regularly updates technical information. Please check with your Karma Automotive Retailer and Karma Automotive service provider that the bulletin you intend to use contains the latest available information.

MODEL: Karma Revero

DATE: July 2017

TITLE: Baseline BL1021 Release

Revised August

The “Update Complete” message will appear at the top left of the screen at the end of the update the status box will also display a green check mark (fig.9c). If the update is incomplete the status box will display a red “x”. A reattempt of the update may be necessary.

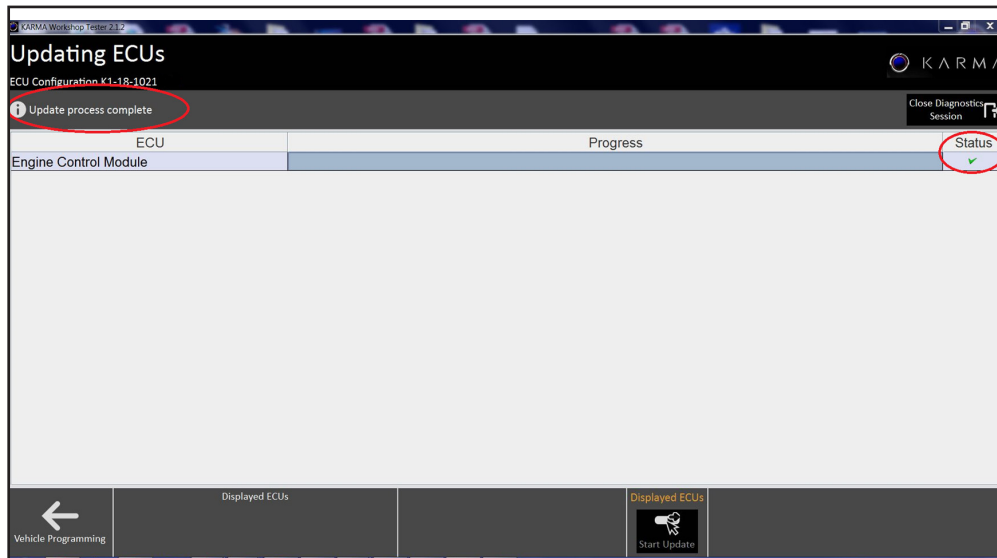

fig.9c

7. When update complete the vehicle will power off by itself.
 Once the update is complete, the vehicle mode dialog will appear. (fig.10)
 Turn the car back on in Accessory Mode

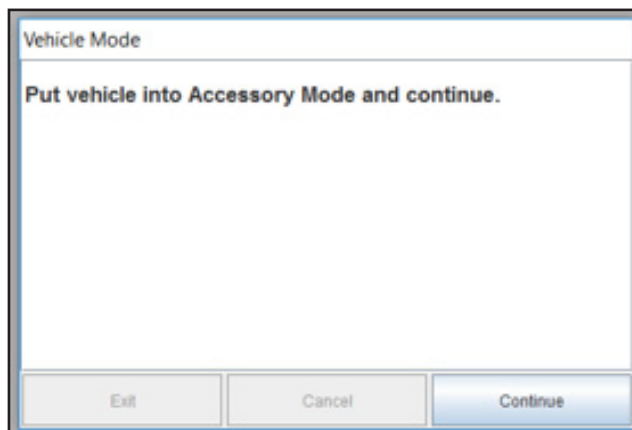

fig.10

Karma Automotive Bulletins and service documents are intended for use by experienced and trained Technicians. If you lack the skills, tools, equipment and a suitable workshop for any procedure described in this document, we suggest you leave such repairs to a Karma retailer and service provider. See your service provider for advice on whether your vehicle may benefit from the information contained within this document. The information contained in the Karma Bulletin is accurate at the date of publication. However, Karma Automotive regularly updates technical information. Please check with your Karma Automotive Retailer and Karma Automotive service provider that the bulletin you intend to use contains the latest available information.

MODEL: Karma Revero

DATE: July 2017

Revised August

TITLE: Baseline BL1021 Release

- After the update is complete back out and go to main menu.
Click on module diagnosis>Powertrain>Engine Control Module>Part Identification (fig.11)

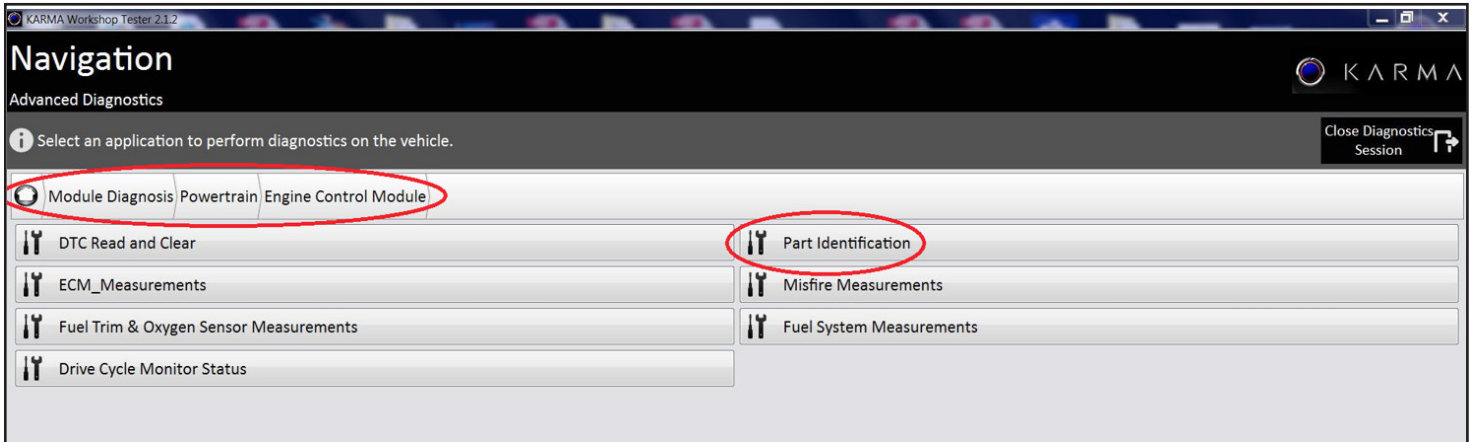

fig.11

- Read the “Calibration Data Module Identifier” and verify that the correct version is installed as shown below: 01270902 (fig. 12).

Control Module	Name	Value
Engine Control Module	Calibration Data Module Identifier	01270902
Engine Control Module	Diagnostic Data Identifier (2):Data Record:Diagnostic Data ID Digit 1 (System Code)	11
Engine Control Module	Diagnostic Data Identifier (2):Data Record:Diagnostic Data ID Digit 2 (Version Code)	0
Engine Control Module	ECU Diagnostic Address:Data Record:ECU Diagnostic Address	17
Engine Control Module	Karma FMSDS Item Number:Data Record:Hardware Part Number	01230300
Engine Control Module	Manufacturers Enable Counter (2):Data Record:Manufacturers Enable Counter	0
Engine Control Module	Software Module Identifier	01210901
Engine Control Module	Vehicle Identification Number	50GK41SA0JA000023

fig.12

Karma Automotive Bulletins and service documents are intended for use by experienced and trained Technicians. If you lack the skills, tools, equipment and a suitable workshop for any procedure described in this document, we suggest you leave such repairs to a Karma retailer and service provider. See your service provider for advice on whether your vehicle may benefit from the information contained within this document. The information contained in the Karma Bulletin is accurate at the date of publication. However, Karma Automotive regularly updates technical information. Please check with your Karma Automotive Retailer and Karma Automotive service provider that the bulletin you intend to use contains the latest available information.

MODEL: Karma Revero

DATE: July 2017

TITLE: Baseline BL1021 Release

Revised August

10. Return to the vehicle diagnosis menu and select full vehicle update as in (fig.13a) and select K1-18-1021.RC1 as shown below (fig.13b).

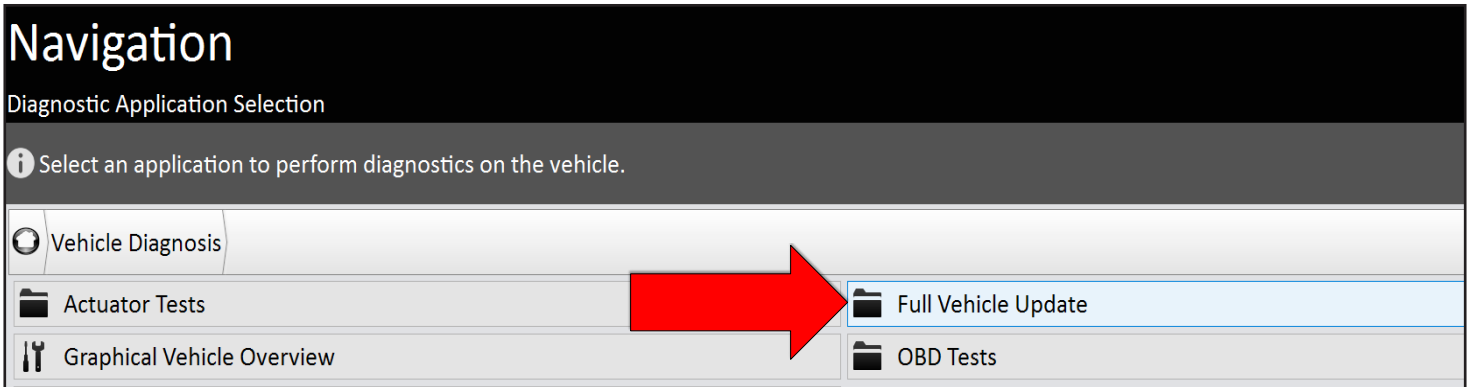

fig.13a

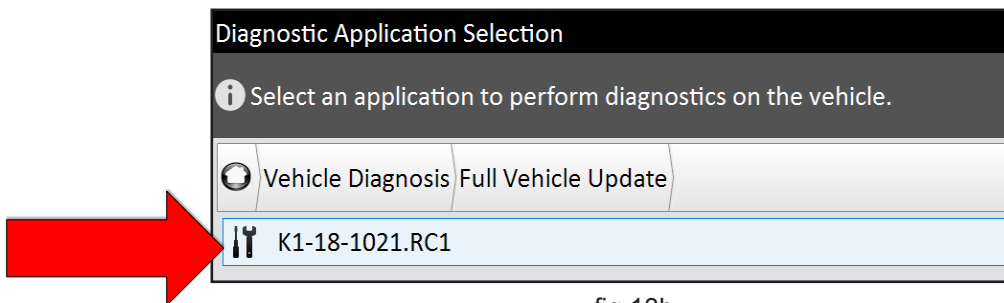

fig.13b

11. Follow the prompts and make sure that a suitable 12V power supply is connected to the vehicle. Click continue (fig.13c)

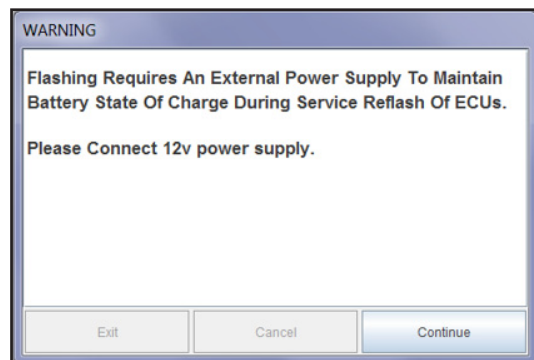

fig.13c

Karma Automotive Bulletins and service documents are intended for use by experienced and trained Technicians. If you lack the skills, tools, equipment and a suitable workshop for any procedure described in this document, we suggest you leave such repairs to a Karma retailer and service provider. See your service provider for advice on whether your vehicle may benefit from the information contained within this document. The information contained in the Karma Bulletin is accurate at the date of publication. However, Karma Automotive regularly updates technical information. Please check with your Karma Automotive Retailer and Karma Automotive service provider that the bulletin you intend to use contains the latest available information.

MODEL: Karma Revero

DATE: July 2017

Revised August

TITLE: Baseline BL1021 Release

12. The flash information will be populated, as before (fig.14)
 - If a pop up opens stating the "OBCM failed to communicate;" disregard this message
 Proceed to click "next" and follow the prompts.

Vehicle Programming
 ECU Configuration K1-18-1021.RC1

Select or deselect ECUs to be flashed

Action	ECU	Target Software	Current Software
✓	Power Inverter Module for Traction (Motor 1)	0281-06-34	0281-06-34
✗	On Board Charge Module	0321-00-07	ECU No RESP
✗	Power Inverter Module for Generator	0301-06-30	0301-06-29
✓	Power Inverter Module for Traction (Motor 2)	0291-06-34	0291-06-34
✓	Accessory Power Module	0311-01-02	0311-01-02
✗	Advanced Driver Assistance System	0381-00-38	0381-00-28
✗	Engine Control Module	0121-09-02	0121-09-01
✗	Vehicle Control Module Security	0411-01-11	0411-01-07
✗	Vehicle Control Module Body	0401-00-24	0401-00-22
✗	Battery Energy Control Module	0156-04-39	0156-04-36
✓	Tire Pressure Monitor System	0371-00-03	0371-00-03
✗	Hybrid Control Unit	0111-0C-54	0111-0C-49
✗	Heat/Ventilation Air Conditioning	0162-02-42	0162-02-40
✗	Memory Seat Module	0441-02-07	0441-02-06
✓	Door Module Right	0431-00-21	0431-00-21
✓	Door Module Left	0421-00-21	0421-00-21

Buttons: Vehicle Overview, Deselect all, Add, Add All, Selected ECUs, Next

fig.14

13. Click **START UPDATE**. The modules which will update are displayed, the module order will will reorganize and ADAS will move to the top of the list once programming starts (fig.15a).

Updating ECUs
 ECU Configuration K1-18-1021.RC1

Please wait. Do not press Start-Stop-Button while flashing.

ECU	Progress	Status
Advanced Driver Assistance System		✗
On Board Charge Module		
Power Inverter Module for Generator		
Engine Control Module		
Vehicle Control Module Body		
Battery Energy Control Module		
Heat/Ventilation Air Conditioning		
Memory Seat Module		
Hybrid Control Unit		
Vehicle Control Module Security		

Buttons: Vehicle Programming, Displayed ECUs, Start Update

fig.15a

Karma Automotive Bulletins and service documents are intended for use by experienced and trained Technicians. If you lack the skills, tools, equipment and a suitable workshop for any procedure described in this document, we suggest you leave such repairs to a Karma retailer and service provider. See your service provider for advice on whether your vehicle may benefit from the information contained within this document. The information contained in the Karma Bulletin is accurate at the date of publication. However, Karma Automotive regularly updates technical information. Please check with your Karma Automotive Retailer and Karma Automotive service provider that the bulletin you intend to use contains the latest available information.

MODEL: Karma Revero

DATE: July 2017

TITLE: Baseline BL1021 Release

Revised August

As instructed place vehicle in Ready Mode (fig.15b)

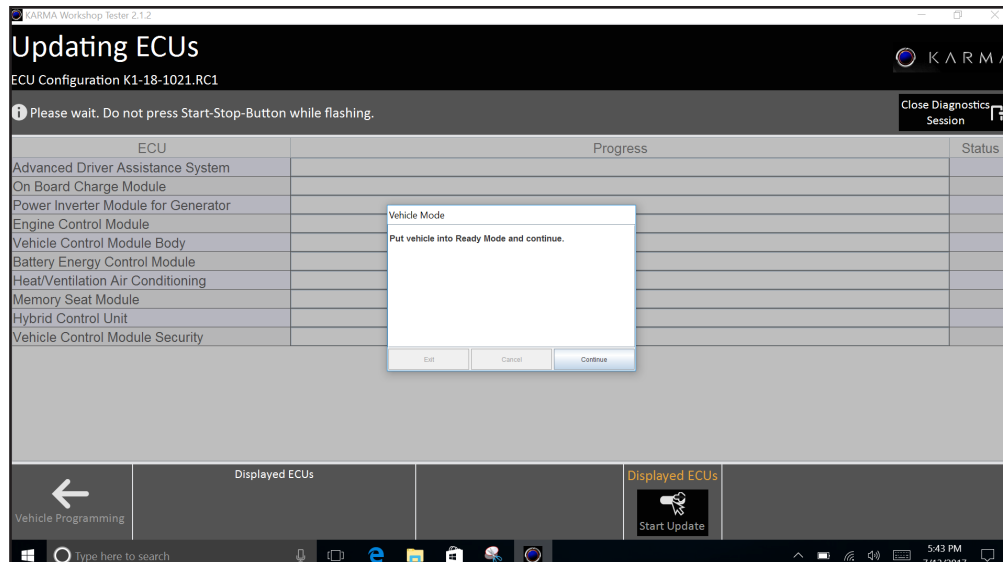

fig.15b

14. Follow the prompts and place the vehicle into accessory mode (fig.16). It is normal for the vehicle to appear to be 'stuck on' during this step of the programming.

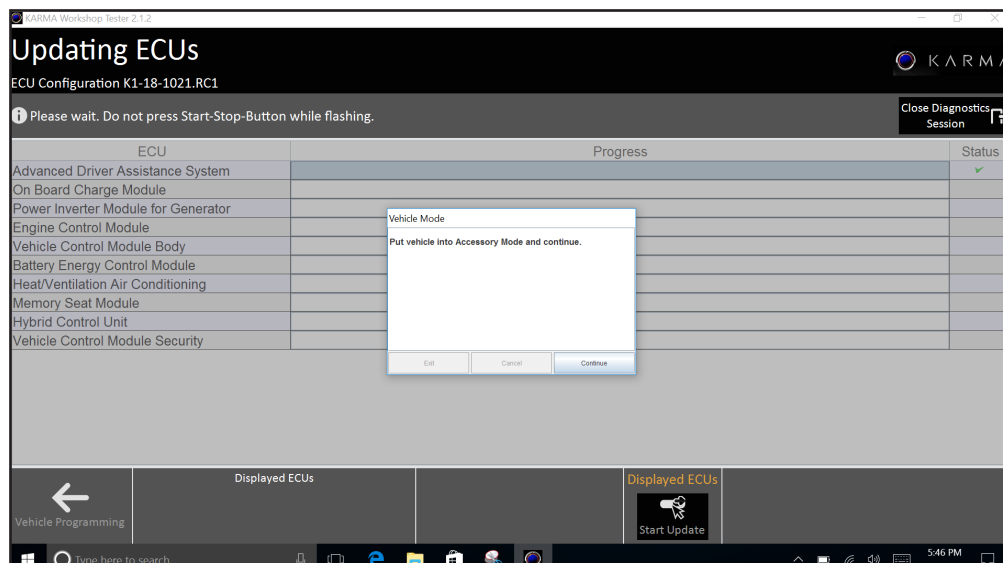

fig.16

Karma Automotive Bulletins and service documents are intended for use by experienced and trained Technicians. If you lack the skills, tools, equipment and a suitable workshop for any procedure described in this document, we suggest you leave such repairs to a Karma retailer and service provider. See your service provider for advice on whether your vehicle may benefit from the information contained within this document. The information contained in the Karma Bulletin is accurate at the date of publication. However, Karma Automotive regularly updates technical information. Please check with your Karma Automotive Retailer and Karma Automotive service provider that the bulletin you intend to use contains the latest available information.

MODEL: Karma Revero

DATE: July 2017

TITLE: Baseline BL1021 Release

Revised August

During the ADAS flash the request to enter Accessory Mode is performed by the vehicle. This may take up to two minutes to complete the ADAS flash. Note: Inspection of the vehicle will show the DIS appearing as Ready mode but the power mode button on the dash is YELLOW, because it is in Accessory Mode. The button state is the tell tale (fig. 17). When complete the Sync tool will proceed follow any prompts provided CAREFULLY.



fig. 17

Karma Automotive Bulletins and service documents are intended for use by experienced and trained Technicians. If you lack the skills, tools, equipment and a suitable workshop for any procedure described in this document, we suggest you leave such repairs to a Karma retailer and service provider. See your service provider for advice on whether your vehicle may benefit from the information contained within this document. The information contained in the Karma Bulletin is accurate at the date of publication. However, Karma Automotive regularly updates technical information. Please check with your Karma Automotive Retailer and Karma Automotive service provider that the bulletin you intend to use contains the latest available information.

MODEL: Karma Revero

DATE: July 2017

TITLE: Baseline BL1021 Release

Revised August

The OBCM will not update and the ECM will show a red “X” as well this is expected in this bulletin at this step (fig. 18a). When complete all modules should appear as below (fig.18b).

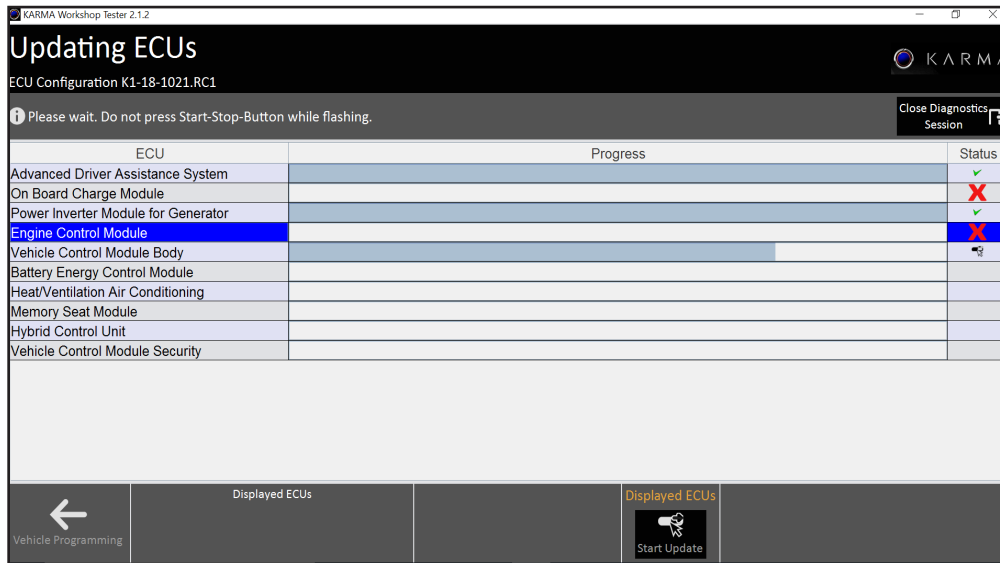

fig.18a

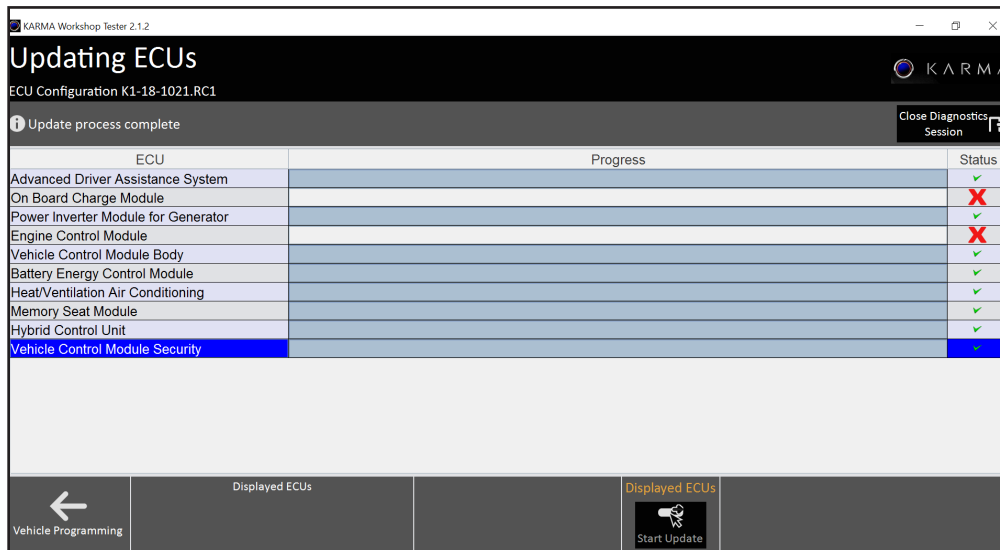

fig.18b

Karma Automotive Bulletins and service documents are intended for use by experienced and trained Technicians. If you lack the skills, tools, equipment and a suitable workshop for any procedure described in this document, we suggest you leave such repairs to a Karma retailer and service provider. See your service provider for advice on whether your vehicle may benefit from the information contained within this document. The information contained in the Karma Bulletin is accurate at the date of publication. However, Karma Automotive regularly updates technical information. Please check with your Karma Automotive Retailer and Karma Automotive service provider that the bulletin you intend to use contains the latest available information.

MODEL: Karma Revero

DATE: July 2017

TITLE: Baseline BL1021 Release

Revised August

15. Follow the prompt to complete the process (fig 19).

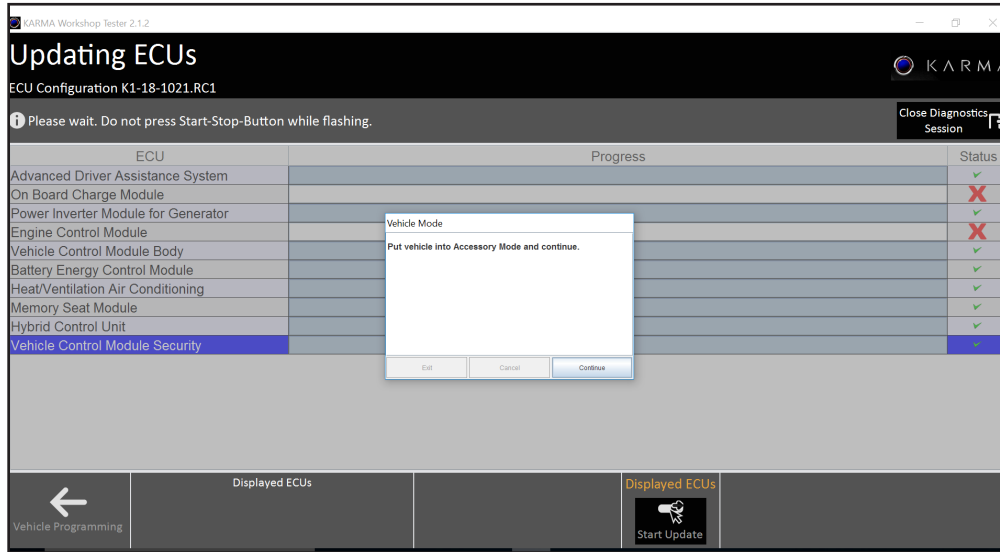

fig.19

16. ADAS post flash procedure will require the vehicle to be placed in Ready Mode (fig. 20). Cycle the mode button to Ready mode.

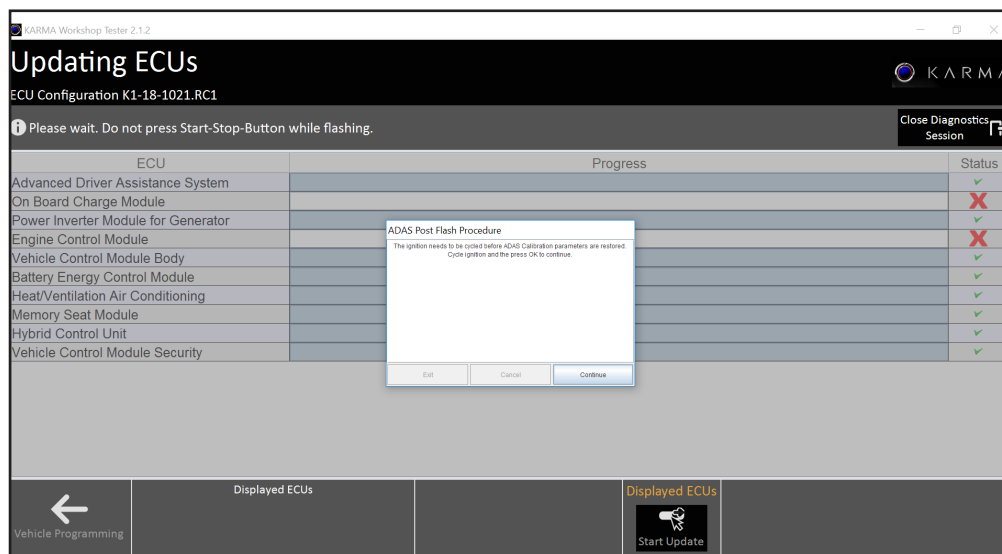

fig.20

Karma Automotive Bulletins and service documents are intended for use by experienced and trained Technicians. If you lack the skills, tools, equipment and a suitable workshop for any procedure described in this document, we suggest you leave such repairs to a Karma retailer and service provider. See your service provider for advice on whether your vehicle may benefit from the information contained within this document. The information contained in the Karma Bulletin is accurate at the date of publication. However, Karma Automotive regularly updates technical information. Please check with your Karma Automotive Retailer and Karma Automotive service provider that the bulletin you intend to use contains the latest available information.

MODEL: Karma Revero

DATE: July 2017

TITLE: Baseline BL1021 Release

Revised August

to repeat, the OBCM will not update and the ECM will show a red “X” as well this is expected in this bulletin at this step (p.23, fig. 18a). When complete all modules should appear as below (p.23, fig.18b). However:

⚠ NOTICE! ⚠

If any other modules fail to update during this procedure, select that module again and update.

The flash information will be populated, as before (fig.20a) - If a pop up opens stating the “OBCM failed to communicate;” disregard this message. Select the modules requiring the update and proceed to click “next” and follow the prompts again if needed.

Vehicle Programming			
ECU Configuration K1-18-1021.RC1			
Select or deselect ECUs to be flashed			
Action	ECU	Target Software	Current Software
✓	Power Inverter Module for Traction (Motor 1)	0281-06-34	0281-06-34
✗	On Board Charge Module	0321-00-07	ECU No RESP
✗	Power Inverter Module for Generator	0301-06-30	0301-06-29
✓	Power Inverter Module for Traction (Motor 2)	0291-06-34	0291-06-34
✓	Accessory Power Module	0311-01-02	0311-01-02
✗	Advanced Driver Assistance System	0381-00-38	0381-00-28
✗	Engine Control Module	0121-09-02	0121-09-01
✗	Vehicle Control Module Security	0411-01-11	0411-01-07
✗	Vehicle Control Module Body	0401-00-24	0401-00-22
✗	Battery Energy Control Module	0156-04-39	0156-04-36
✓	Tire Pressure Monitor System	0371-00-03	0371-00-03
✗	Hybrid Control Unit	0111-0C-54	0111-0C-49
✗	Heat/Ventilation Air Conditioning	0162-02-42	0162-02-40
✗	Memory Seat Module	0441-02-07	0441-02-06
✓	Door Module Right	0431-00-21	0431-00-21
✓	Door Module Left	0421-00-21	0421-00-21

← Vehicle Overview

Displayed ECUs

✗ Deselect all
✚ Add
✚ Add All

Selected ECUs

✚ Next

fig.20a

Karma Automotive Bulletins and service documents are intended for use by experienced and trained Technicians. If you lack the skills, tools, equipment and a suitable workshop for any procedure described in this document, we suggest you leave such repairs to a Karma retailer and service provider. See your service provider for advice on whether your vehicle may benefit from the information contained within this document. The information contained in the Karma Bulletin is accurate at the date of publication. However, Karma Automotive regularly updates technical information. Please check with your Karma Automotive Retailer and Karma Automotive service provider that the bulletin you intend to use contains the latest available information.

MODEL: Karma Revero

DATE: July 2017

TITLE: Baseline BL1021 Release

Revised August

17. The update is complete with Karma Sync. Any codes need to be cleared in READY state. Ignore the pop-up of cycling state to ACCESSORY in Karma SYNC. Proceed to clear any DTC's present in the system. (fig.21a, b,c)

-If nothing is able to clear allow the vehicle to sleep for 10 minutes and make another attempt.

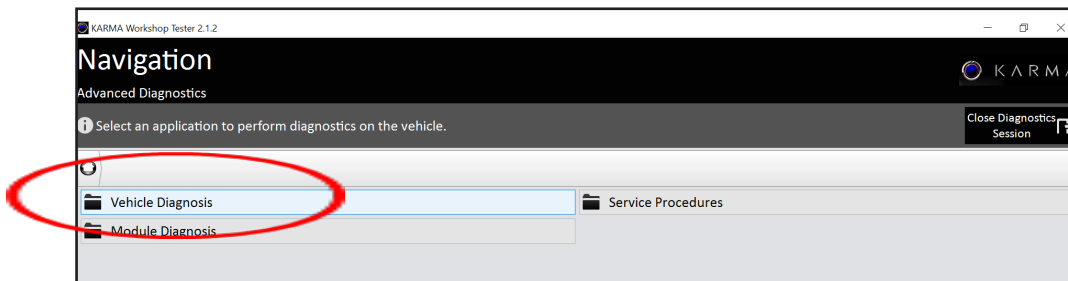

fig.21a

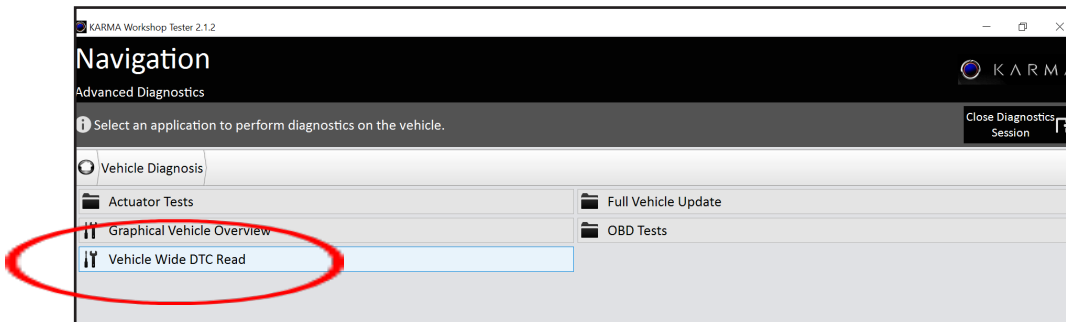

fig.21b

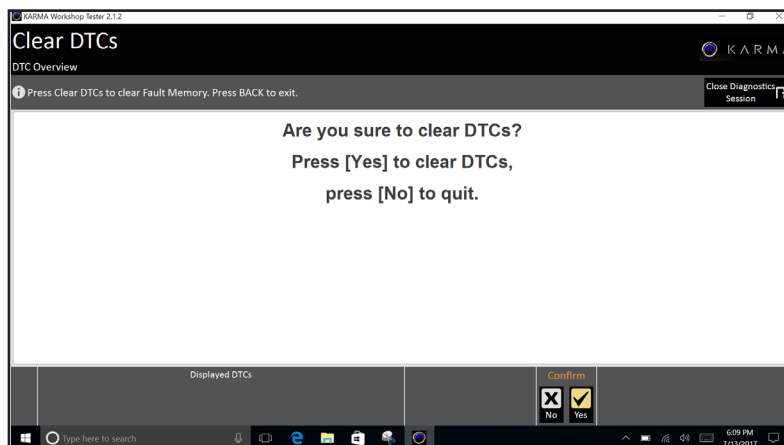

fig.21c

Karma Automotive Bulletins and service documents are intended for use by experienced and trained Technicians. If you lack the skills, tools, equipment and a suitable workshop for any procedure described in this document, we suggest you leave such repairs to a Karma retailer and service provider. See your service provider for advice on whether your vehicle may benefit from the information contained within this document. The information contained in the Karma Bulletin is accurate at the date of publication. However, Karma Automotive regularly updates technical information. Please check with your Karma Automotive Retailer and Karma Automotive service provider that the bulletin you intend to use contains the latest available information.

MODEL: Karma Revero

DATE: July 2017

TITLE: Baseline BL1021 Release

Revised August

Note: Remove the Karma Sync Equipment. Before the CIU is updated ensure nothing is plugged into the OBD II port. This includes the WDI - remove this, otherwise the TPI will cycle on and off, this is expected behavior. However, this will interrupt the update. The Karma Sync is also not needed for this over the air (OTA) update.

18. Central Infotainment Unit flashing will occur over the air, TSS is required to be notified prior to this step. TSS will instruct you to place the vehicle in Ready Mode while the update packet is downloaded to the vehicle- the download requires no other action on the technician's part, only to leave the vehicle in a secure and safe location in your work area for approximately thirty (30) minutes.

19. Keep the door latched (closed position) the update will not show up on TPI until power button is powered off with door still latched. This is when you can verify the TPI for update available messaging screen. If the download completed, the vehicle will prompt to accept the update (Fig. 22) Accept this and allow the vehicle to update. Note that changing the door latch state will interrupt the accessory delay and shut down the TPI. If the TPI shuts down at power off, the update available screen will not display.

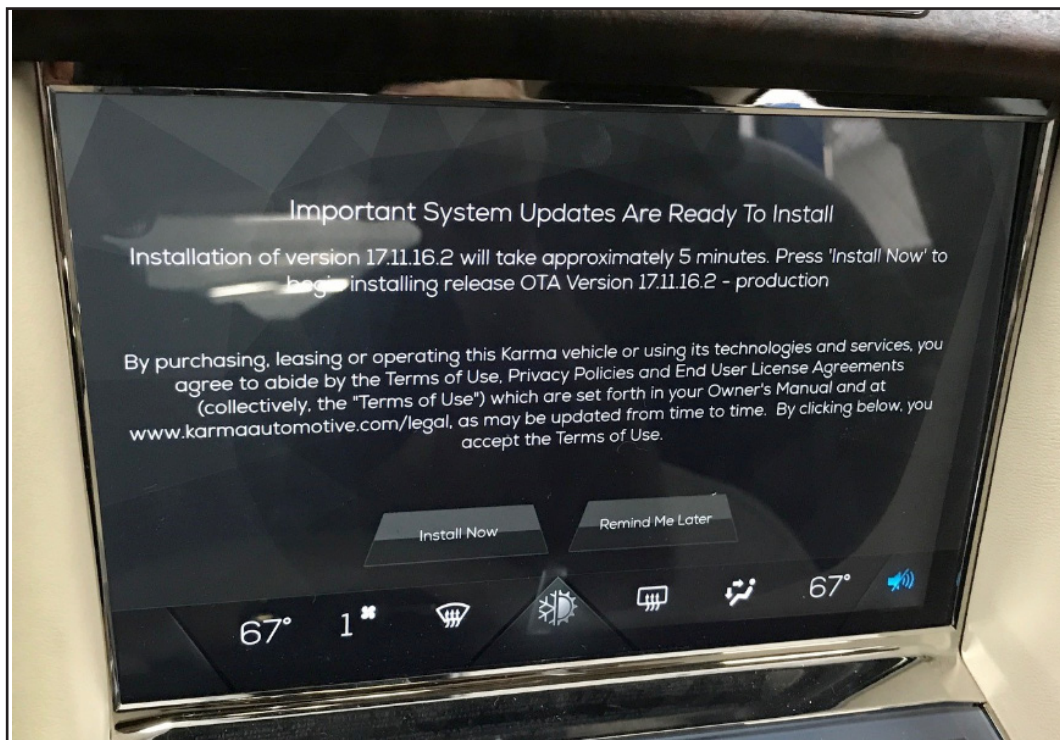

fig. 22

Karma Automotive Bulletins and service documents are intended for use by experienced and trained Technicians. If you lack the skills, tools, equipment and a suitable workshop for any procedure described in this document, we suggest you leave such repairs to a Karma retailer and service provider. See your service provider for advice on whether your vehicle may benefit from the information contained within this document. The information contained in the Karma Bulletin is accurate at the date of publication. However, Karma Automotive regularly updates technical information. Please check with your Karma Automotive Retailer and Karma Automotive service provider that the bulletin you intend to use contains the latest available information.

MODEL: Karma Revero

DATE: July 2017

Revised August

TITLE: Baseline BL1021 Release

Below are the screens of the TPI read out as the CIU is updating (Fig.23 a,b,c,d,e) When this is completed updating, the screen may go blank or black or cycle on and off, normal function will resume upon cycling the mode button.

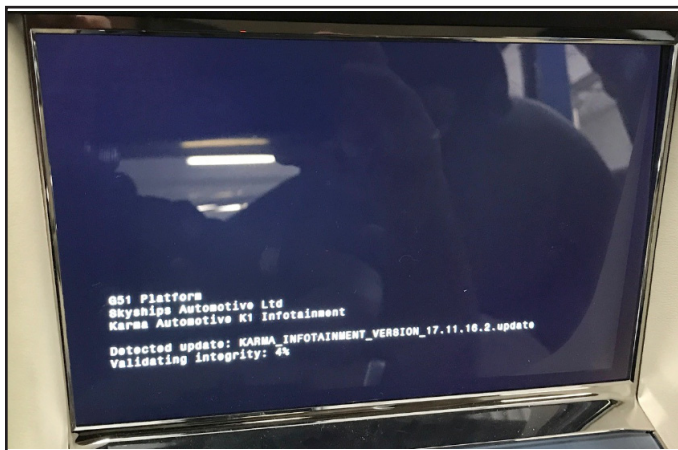

fig. 23a



fig. 23b



fig. 23c



fig. 23d

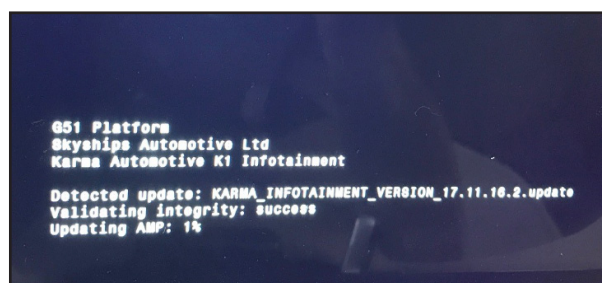

fig. 23e

Karma Automotive Bulletins and service documents are intended for use by experienced and trained Technicians. If you lack the skills, tools, equipment and a suitable workshop for any procedure described in this document, we suggest you leave such repairs to a Karma retailer and service provider. See your service provider for advice on whether your vehicle may benefit from the information contained within this document. The information contained in the Karma Bulletin is accurate at the date of publication. However, Karma Automotive regularly updates technical information. Please check with your Karma Automotive Retailer and Karma Automotive service provider that the bulletin you intend to use contains the latest available information.

MODEL: Karma Revero

DATE: July 2017

TITLE: Baseline BL1021 Release

Revised August

This is the image of the DIS during the update (fig. 24)



fig. 24

20. Verify the CIU software ID in the TPI after the vehicle has been placed in ready mode. go to Setting > About, the version should be displayed above the Terms and Conditions bar (fig 25.)

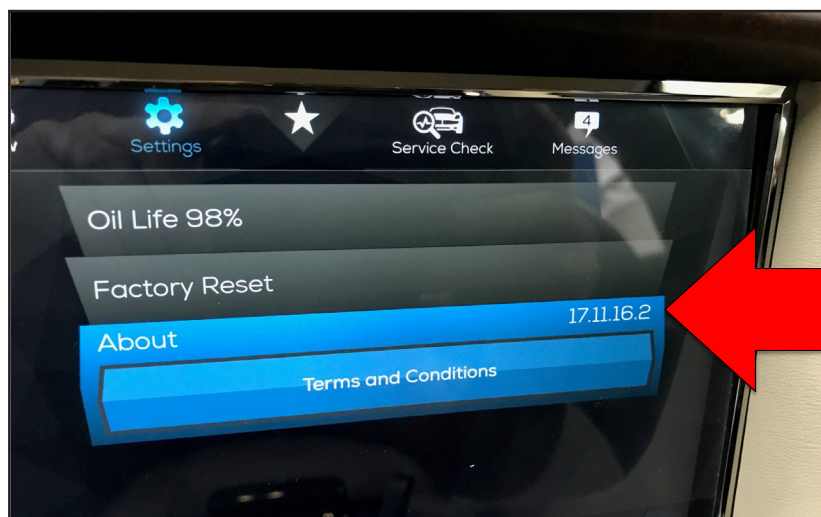

fig. 25

Test drive the vehicle and ensure everything is functioning correctly and address any DTC's before returning vehicle to the customer. The CIU Software ID should be as displayed- 17.11.16.2.

Karma Automotive Bulletins and service documents are intended for use by experienced and trained Technicians. If you lack the skills, tools, equipment and a suitable workshop for any procedure described in this document, we suggest you leave such repairs to a Karma retailer and service provider. See your service provider for advice on whether your vehicle may benefit from the information contained within this document. The information contained in the Karma Bulletin is accurate at the date of publication. However, Karma Automotive regularly updates technical information. Please check with your Karma Automotive Retailer and Karma Automotive service provider that the bulletin you intend to use contains the latest available information.

MODEL: Karma Revero

DATE: July 2017

TITLE: Baseline BL1021 Release

Revised August

A 12V reset does not need to be performed unless directed by TSS.

As a reminder, to perform a 12 volt hard reset:

1. Open the fuse box under the hood (PDC) and remove fuse 10 (fig.22a, SPBC - solar panel boost controller)
2. Disconnect the main 12V ground disconnect (fig.22b)
3. Reconnect in reverse

NOTE: Do not install the solar fuse before connecting the main 12V ground as this will cause under voltage to the control units and may cause new concerns.

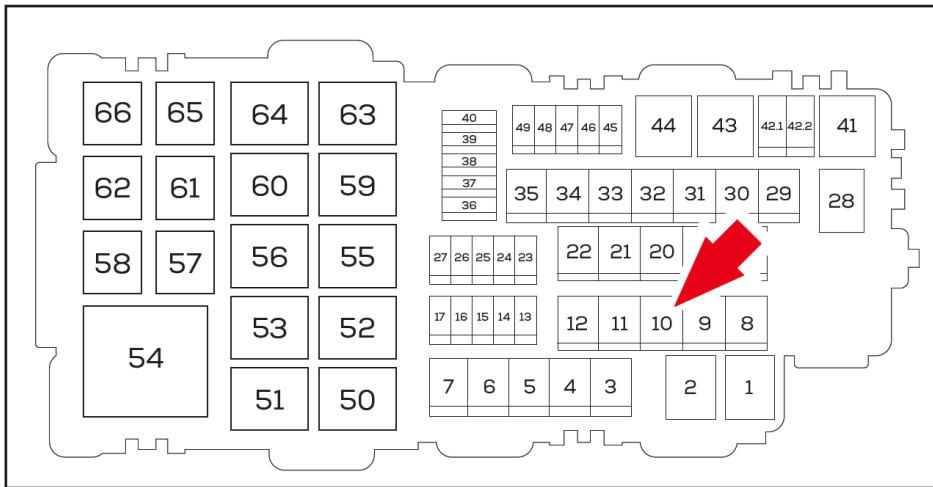

fig.22a

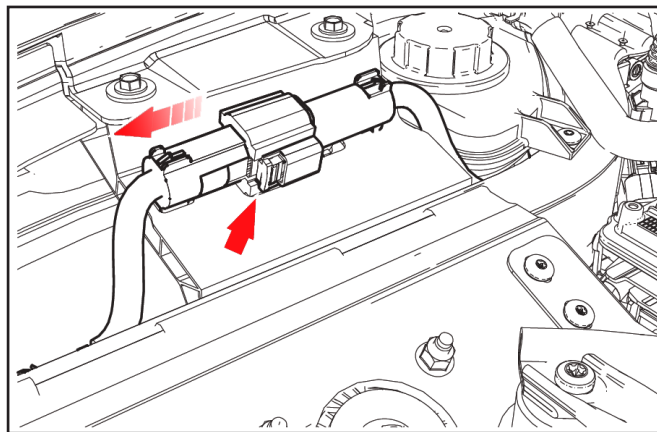

fig.22b

Karma Automotive Bulletins and service documents are intended for use by experienced and trained Technicians. If you lack the skills, tools, equipment and a suitable workshop for any procedure described in this document, we suggest you leave such repairs to a Karma retailer and service provider. See your service provider for advice on whether your vehicle may benefit from the information contained within this document. The information contained in the Karma Bulletin is accurate at the date of publication. However, Karma Automotive regularly updates technical information. Please check with your Karma Automotive Retailer and Karma Automotive service provider that the bulletin you intend to use contains the latest available information.



Service Bulletin

TB-17-00-11

MODEL: Karma Revero

DATE: July 2017

Revised August

TITLE: Baseline BL1021 Release

PARTS REQUIRED:

PART NUMBER	DESCRIPTION
N/A	N/A

SHOP SUPPLIES:

DESCRIPTION
N/A

SPECIAL TOOLS:

DESCRIPTION
N/A

CAUSAL PART:

PART NUMBER	DESCRIPTION
C161113201001	Engine Control Module

LABOR CODES:

CODE	DESCRIPTION	TIME	DEFECT CODE
00-99-24-35	BL1021 Software Install	1.0	00-99-20-98

SUBLET:

CODE	DESCRIPTION	AMOUNT
N/A		

WARRANTY DISPOSITION: This repair is covered under the New Vehicle Limited Warranty, in effect for five (5) years from the in-service date with no mileage limitation.

Karma Automotive Bulletins and service documents are intended for use by experienced and trained Technicians. If you lack the skills, tools, equipment and a suitable workshop for any procedure described in this document, we suggest you leave such repairs to a Karma retailer and service provider. See your service provider for advice on whether your vehicle may benefit from the information contained within this document. The information contained in the Karma Bulletin is accurate at the date of publication. However, Karma Automotive regularly updates technical information. Please check with your Karma Automotive Retailer and Karma Automotive service provider that the bulletin you intend to use contains the latest available information.