



RECREATIONAL VEHICLE SERVICE CAMPAIGN

June 21, 2017

Service Advisory: 17-286

SERVICE CAMPAIGN

«Owner_name»
«Street»
«City», «State» «Zip»
«Country»

VIN: «VIN»

Dear «Owner_name»:

Keystone RV Company is conducting a service campaign on certain 2017-2018 Impact Fifth Wheels. We apologize for any inconvenience this action may cause you; however your continued satisfaction is of the utmost importance to us.

Reason for this campaign

It has been determined that on some 2017-2018 Impact models the air conditioner was wired incorrectly preventing the compressor from running.

What we will do

Keystone has notified our dealers regarding this situation. The remedy is to correct the wiring on the A/C control box. The service required for this corrective action will be provided at no charge to you.

What we need you to do

At your earliest convenience, please make an appointment to have your RV serviced by your dealership. The labor time to perform this campaign is approximately ½ hour. Please ask your dealer if you wish to know how much additional time will be needed to schedule and process your RV for this repair.

If you have questions

Your dealer is best equipped to obtain parts and provide service to ensure your RV is corrected as promptly as possible. If your dealer is unable to assist or if you take your RV to your dealer on the agreed service date, and the dealer does not remedy the condition within a reasonable amount of time, or without charge to you, please contact Keystone Customer Service by calling 1-866-425-4369.

Thank you for your attention and cooperation in this matter.

Sincerely,

KEYSTONE RV COMPANY

Rick Deisler
Vice President Service Operations

PO Box 2000 Goshen, IN 46527-2000
Phone: (574) 535-2100 – Fax: (574) 535-2199
www.keystonerv.com

SERVICE ADVISORY # 17-286

Impact Rear A/C Wiring

It has been determined that on some 2017-2018 Impact models the air conditioner was wired incorrectly preventing the compressor from running. This advisory explains how to correct the problem if it exists.

- Models Included:** 2017 Impact: 311, 3219, 341, 351, 361
2018 Impact: 311, 3219, 341, 351, 361
- Serial Number Ranges:** 2017: HF815588 – HF815800
2018: JF815000 – JF815055
- Parts Required:** 12-gauge electrical spade connector purchased locally
- Tools Required:** - Wire crimps/cutter

Note – Check serial number on Key Express to verify the campaign is open.

REPAIR INSTRUCTIONS

Step 1

Locate the rear A/C control box, Figure 1. The wiring must be corrected as follows.

Step 2

The following two actions will need to be taken:

1. Remove **blue** wire from terminal “Y” and attach it to the white wire on the “B-” using a 12-gauge spade connector.
2. Move **white** wire from terminal “W” to “Y”. There will be nothing attached to the “W” terminal. See Figure 2.

Steps 4-7 explain in detail the proper way to accomplish these three actions.

Step 4

Disconnect 110V and 12-volt power to the unit.

Step 5

Remove the white wire on terminal “B-” and the blue wire on terminal “Y”. Cut the existing spade connectors off each wire and attach them together using a 12-gauge spade connector. Install new connector on terminal “B-”.

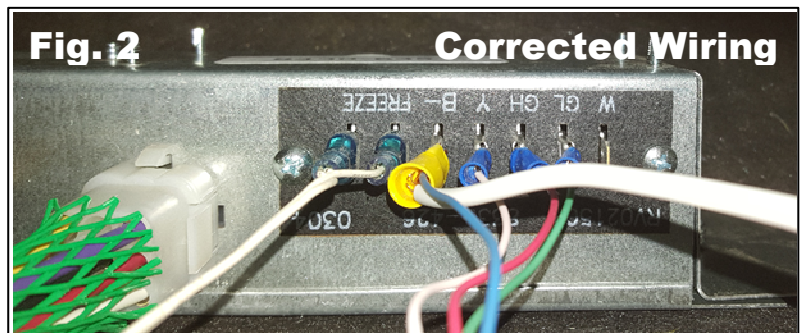
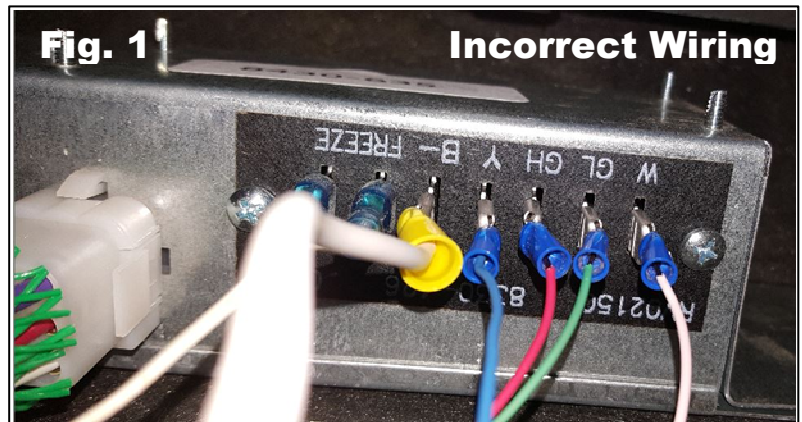

Step 6

Remove the white wire attached to terminal “W” and move it to the “Y” terminal. See wiring diagram in Figure 3.

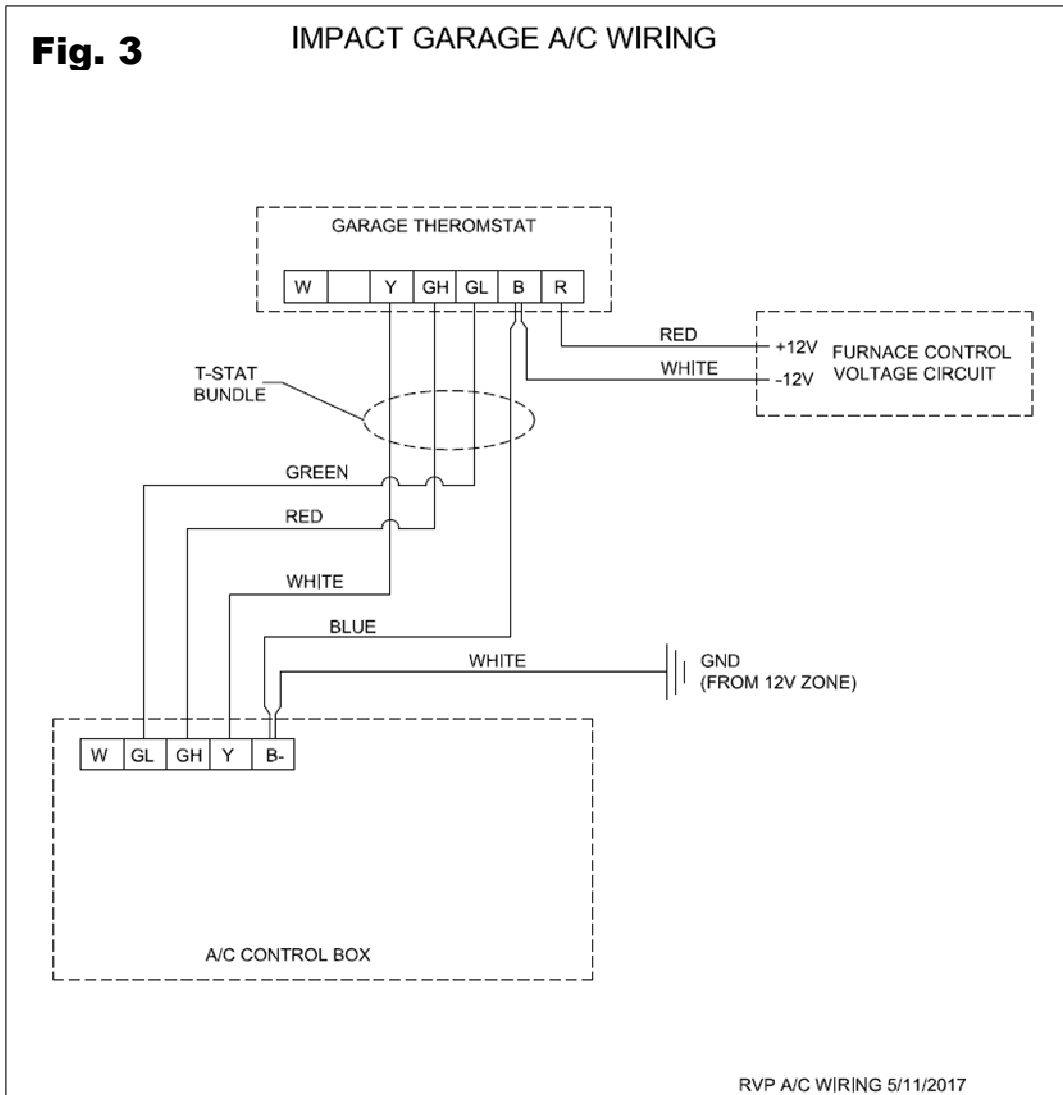

Step 7

Proceed to the warranty reimbursement section.

WARRANTY REIMBURSEMENT

Submit the claim on Key Express using **Flat Rate Code # 7128642A** with **Service Advisory # 17-286** noted in the customer complaint section. The amount of time authorized for repair is **0.5 hour**.

If you have questions, please contact Customer Service: **(866) 273-1452**



RECREATIONAL VEHICLE SERVICE CAMPAIGN

June 21, 2017

SERVICE ADVISORY 17-286

«Dealer_name»
ATTN: Service Manager
«Street»
«Street_2»
«City», «State» «Zip»
«Country»

Dear «Dealer_name»,

Reason for this campaign It has been determined that on some 2017-2018 Impact models the air conditioner was wired incorrectly preventing the compressor from running.

The campaign population includes:

2017-2018 Impact Fifth Wheels, Models 311, 3219, 341, 351, 361
Serial Number Ranges: 2017: HF815588 – HF815800
2018: JF815000 – JF815055

Our records indicate unit(s) sold or in your present lot inventory fall within this range, which will require inspection. **Important:** Please complete the service campaign on these units before retail delivery. Our records indicate the following unit serial number(s) are presently in your inventory or have been sold:

«VIN1» «VIN2» «VIN3» «VIN4»
«VIN5» «VIN6»

-- Serial numbers with '*' have been retail sold --

We apologize for any inconvenience this situation may cause and greatly appreciate your cooperation. Should you have any questions or concerns regarding this correspondence or the enclosed Service Advisory, please contact us at: **(866) 273-1452**

Sincerely,

KEYSTONE RV COMPANY

Rick Deisler
Vice President Service Operations

PO Box 2000 Goshen, IN 46527-2000
Phone: (574) 535-2100 – Fax: (574) 535-2199
www.keystonerv.com