

LTB00827NAS7

TECHNICAL BULLETIN

01 MAY 2017



© Jaguar Land Rover North America, LLC

NOTE: The information in Technical Bulletins is intended for use by trained, professional Technicians with the knowledge, tools, and equipment required to do the job properly and safely. It informs these Technicians of conditions that may occur on some vehicles, or provides information that could assist in proper vehicle service. The procedures should not be performed by 'do-it-yourselfers'. If you are not a Retailer, do not assume that a condition described affects your vehicle. Contact an authorized Land Rover service facility to determine whether this bulletin applies to a specific vehicle.

INFORMATION

This reissue replaces all previous versions. Please destroy all previous versions.

Changes are highlighted in blue

SECTION:

501-29

SUBJECT/CONCERN:

Ticking Noise From 'B' Pillar Area

AFFECTED VEHICLE RANGE:

MODEL:	MODEL YEAR:	VIN:	ASSEMBLY PLANT:
Discovery Sport (LC)	2015 Onwards	500429 Onwards	Halewood

MARKETS:

NORTH AMERICA

CONDITION SUMMARY:

SITUATION:

A ticking noise may be evident from the 'B' pillar area.

CAUSE:

This may be caused by the 'B' pillar panel clearance being incorrect.

ACTION:

Should a customer express this concern, follow the necessary Service Instruction(s) below.

PARTS:

PART NUMBER	DESCRIPTION	QUANTITY:
LR066989	Panoramic roof clips	7
LR078366	Rear headliner clips	1
LR006101	Overhead console clips	2
LR013135	Lantern clips	6
LR036129	Metal clips	4
LR031782	'C' pillar metal clips	10
LR043932	Blind rivet - 6.5 X 23.7	6

WARRANTY:

NOTE:

An allowance equivalent approximately \$37.50 USD has been allocated for locally sourcing of paint and materials; claim using ZZZ001.

NOTES:

- Repair procedures are under constant review, and therefore times are subject to change; those quoted here must be taken as guidance only. Always refer to TOPIx to obtain the latest repair time.

- DDW requires the use of causal part numbers. Labor only claims must show the causal part number with a quantity of zero.

DESCRIPTION	SRO	TIME (HOURS)	CONDITION CODE	CAUSAL PART
Repair for 'B' pillar panel rework - Left	76.11.61	0.1	12	LR061697
Repair for 'B' pillar panel rework - Right	76.11.62	0.1	12	LR061697
Repair for 'B' pillar panel rework - Pair	76.11.63	0.2	12	LR061697
Repair for Cant Rail panel 'creak' noise - Left	76.11.46	0.3	12	LR061697
Repair for Cant Rail panel 'creak' noise - Right	76.11.47	0.3	12	LR061697
Repair for Cant Rail panel 'creak' noise - Pair	76.11.48	0.4	12	LR061697
Repair for noises from door apertures - Pair	76.10.89.24	0.8	12	LR061697
Repair for noises from door apertures - Left	76.10.89.23	0.4	12	LR061697
Repair for noises from door apertures - Right	76.10.89.21	0.4	12	LR061697
Repair for 'A' Pillar front header panel	77.28.31	0.2	12	LR061697
Repair for 'B' pillar spot weld - Left	76.11.64	0.1	12	LR061697
Repair for 'B' pillar spot weld - Right	76.11.65	0.1	12	LR061697
Repair for 'B' pillar spot weld - Pair	76.11.66	0.2	12	LR061697

DESCRIPTION	SRO	TIME (HOURS)	CONDITION CODE	CAUSAL PART
Repair for seatbelt anchor - Pair	76.11.67	0.5	12	LR061697
Repair for seatbelt anchor - Left	76.10.89.15	0.3	12	LR061697
Repair for seatbelt anchor - Right	76.11.89.07	0.3	12	LR061697
Repair for 'B' pillar upper panel 'creak' - Pair - Paint time included	76.10.89.25	5.3	12	LR061697
'B' pillar - LH - Complete - Touch-up (Brush)	79.N.TA7	0.1	12	LR061697
'B' pillar - RH - Complete - Touch-up (Brush)	79.N.UA7	0.1	12	LR061697
Aperture - Door - Rear - LH - Complete - Touch-up (Brush)	79.N.FA7	0.1	12	LR061697
Aperture - Door - Rear - RH - Complete - Touch-up (Brush)	79.N.GA7	0.1	12	LR061697
Aperture - Door - Front - LH - Complete - Touch-up (Brush)	79.N.CA7	0.1	12	LR061697
Aperture - Door - Front - RH - Complete - Touch-up (Brush)	79.N.DA7	0.1	12	LR061697
Carry out road test	10.41.17	0.3	12	LR061697

NOTE:

Normal Warranty procedures apply.

SERVICE INFORMATION:

NOTE:

To provide clear and accurate information in the following service information / repair procedures, this technical bulletin should be viewed in color.

-
- 1 To help with the identification and isolation of suspect squeaks and rattles, first remove from the vehicle, all items that are not supplied as built. For example, CDs, keys, bags, coins, etc. Empty all compartments such as glovebox, glasses case, door pockets, etc. Make sure all vehicle accessories are secure, for example, lifting jack, wrench, etc.

 - 2 The noise is more evident at warmer ambient temperatures. The car should be tested when the engine is warm. It may also be ideal to run the heaters on a high heat setting for a short period of time to increase the interior ambient temperature of the structure.

 - 3 A Customer may express a concern that there is a 'ticking' noise from the 'B' pillar area. While this is the Customer's perceived symptom, sound can travel throughout the vehicle structure from its point of origin, and appear to originate elsewhere. This bulletin contains known symptoms that have been described as 'B' pillar ticking.
-

4

NOTE:

Examples of road surfaces.



E205567

It may prove beneficial to travel at different speeds over each road surface. For example, one pass at 20 km/h (12 mph) and another at 10 km/h (6 mph). These conditions may need to be varied until the Customer symptom can be heard.

-
- 5 There are various sounds generated within the 'B' pillar system, varying in intensity. Reduce the internal passenger compartment noise to assist in locating any generated sounds. This can be done by reducing the heater blowers to the lowest level, or switching them off, as well as the radio. Closing the windows will also reduce the internal passenger compartment noise. Other noises caused by weather, temperature and road surface should also be taken into consideration.

6

WARNING:

Adhere to safe driving practices at all times.

Ask the Customer for details of their concern, taking notes of the conditions. How long does the issue take to occur on any given journey? This should indicate the minimum time required for validation. Where possible, upon the Customer's arrival to the Retailer, perform a road test with the Customer present in the vehicle. This may provide more suitable test conditions and will help to verify the Customer's concern. Record the sound where possible and try to determine the location of the sound.

-
- 7 Refer to Squeaks and Rattles (see TOPIx workshop manual section 501-00: Diagnosis and Testing - Squeaks and Rattles) for other areas of concern.

8 WARNING:

Adhere to safe driving practices at all times.

Hand the vehicle over to the body shop. Perform a road test with the body shop Technician in the vehicle to demonstrate the Customer concern.

-
- 9 Repeat the road test if required and remove appropriate interior trim if this is necessary to assist in locating the noise.
-
- 10 It is important to perform the service instruction below in the order shown, from the beginning until the issue is resolved.

REPAIR FOR 'B' PILLAR PANEL

NOTES:

- Repeat this step on both sides of the vehicle if required.
- Left-side shown; right-side similar.

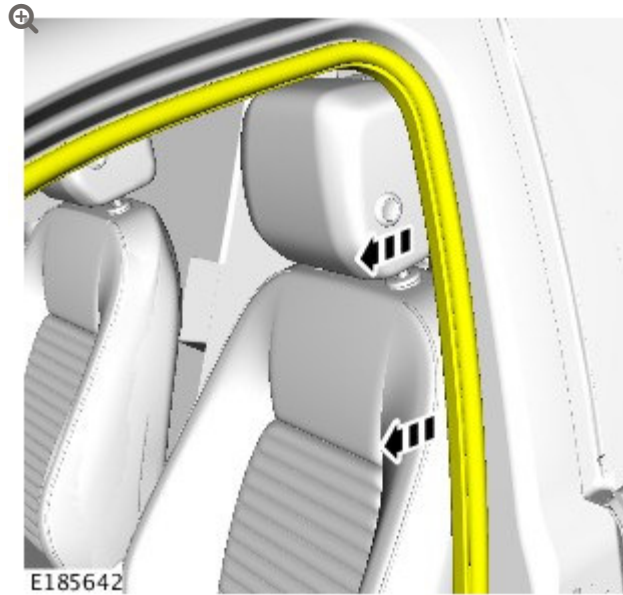

Move aside the front door aperture seal from the door aperture.

2**CAUTIONS:**

- Make sure the surrounding area is protected to avoid damaging the vehicle.
- Make sure to use a blunt and protected suitable tool to prevent damage to the vehicle.
- Any body panels which have been modified/altered must be returned to their original manufacturing condition.

NOTES:

- Repeat this step on both sides of the vehicle if required.
- Left-side shown; right-side similar.
- If necessary, refer to Body Repairs (see TOPIx workshop manual section 501-25A: Description and Operation - Body repairs) for further information on body panel repairs.

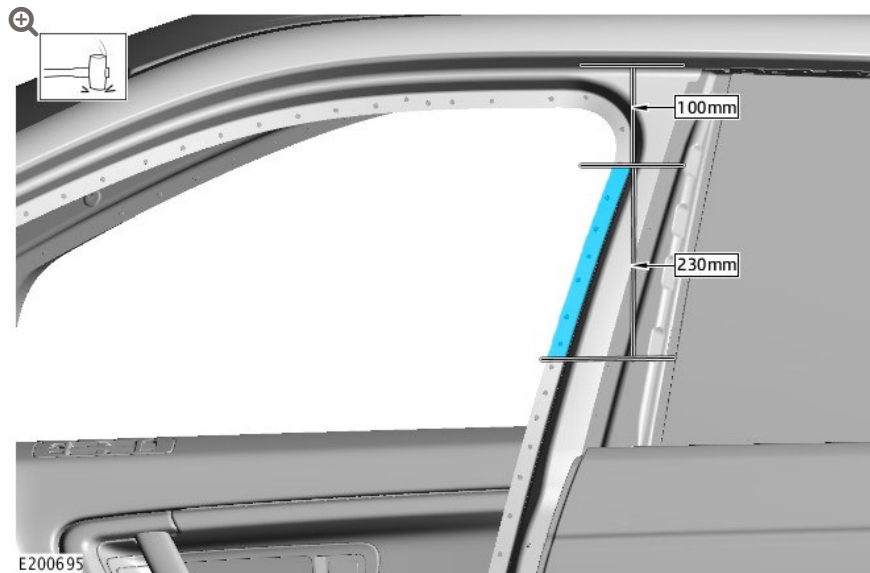

Using a suitable tool, strike the panel with as much force as can safely be applied inwards over the highlighted area shown.

- Repeat along the highlighted area shown.
 - This will eliminate the noise from this area.

3

CAUTION:

Make sure a locally sourced zinc-rich primer is applied to any bare metal surfaces.

Rectify any paint defects if required.

4

NOTES:

- Repeat this step on both sides of the vehicle if required.
- Left-side shown; right-side similar.

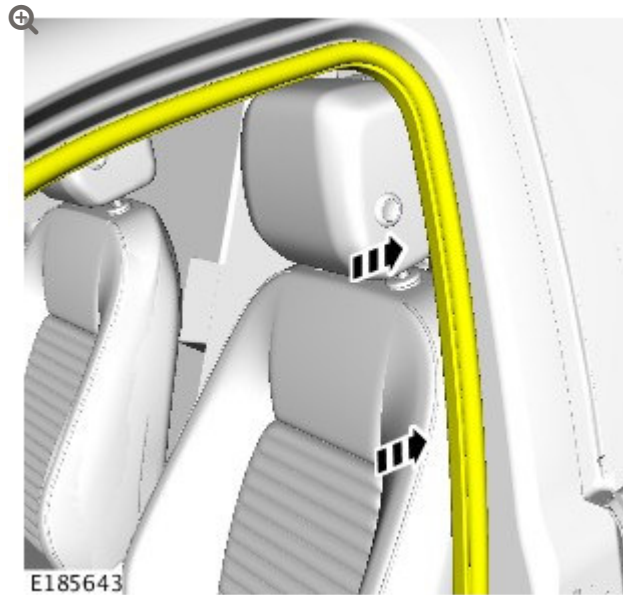

Install the front door aperture seal to the door aperture.

5 Road test the vehicle.

- If the noise **cannot** be heard, return the vehicle to the Customer. Confirm with the Customer that the originally reported noise has been rectified, a further road test with the Customer may be required.
- If the noise **can** still be heard continue to the **Repair for Cant Rail Panel 'Creak' Noise** service instruction.

REPAIR FOR CANT RAIL PANEL 'CREAK' NOISE

CAUTION:

A suitable chisel with a blade width of no more than 12mm and a maximum thickness of 5mm must be used to complete this service instruction.

1

NOTES:

- Repeat this step on both sides of the vehicle if required.
- Left-side shown; right-side similar.

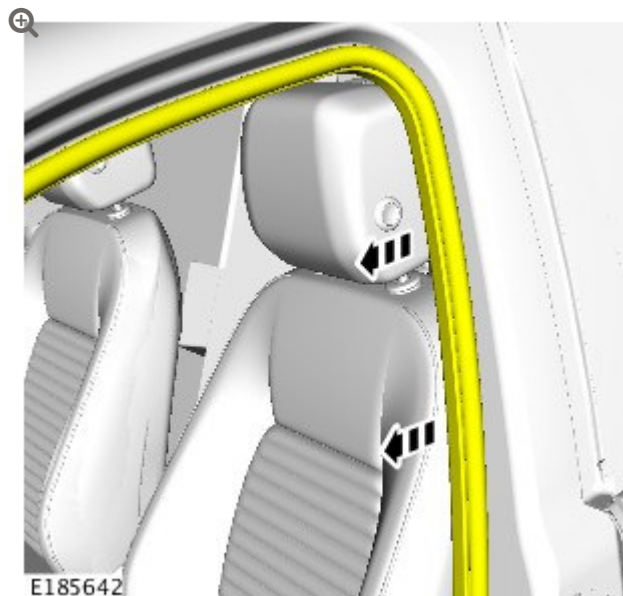

Move aside the front door aperture seal from the door aperture.

2

NOTES:

- If necessary, refer to Body Repairs (see TOPIx workshop manual section 501-25A: Description and Operation - Body repairs) for further information on body panel repairs.
- Left-side shown; right-side similar.

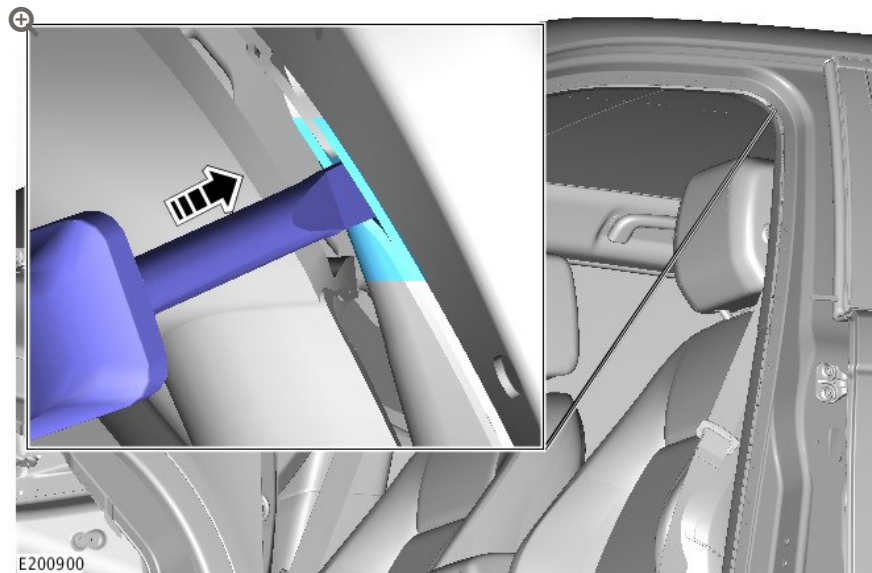

Using a suitable hammer, insert the suitable chisel between the inner 'B' pillar and the cant rail to a maximum depth of 20mm.

- This will cause the inner 'B' pillar panel and the cant rail to separate.
 - This will eliminate the noise from this area.

3

CAUTION:

Any body panels which have been modified/alterd must be returned to their original manufacturing condition.

NOTE:

Left-side shown; right-side similar.

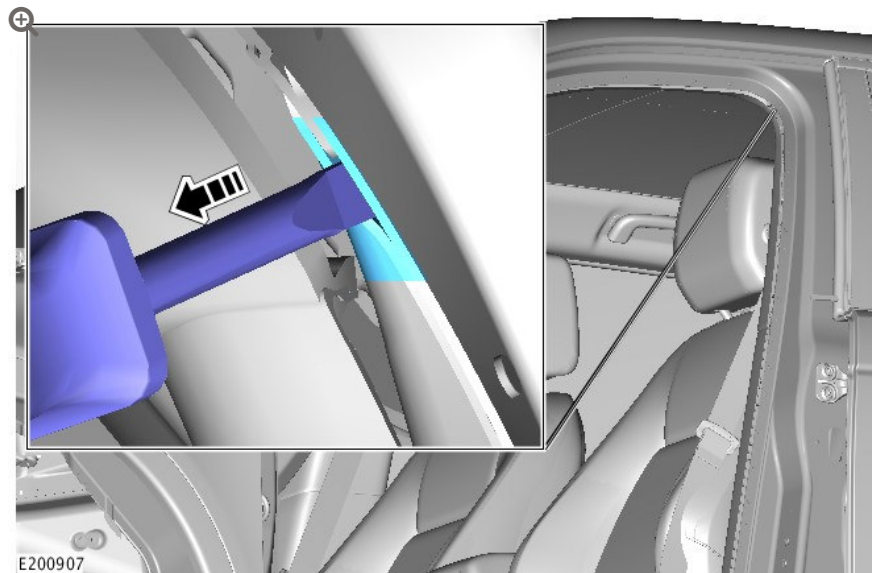

Remove the suitable chisel.

4

CAUTION:

Make sure a locally sourced zinc-rich primer is applied to any bare metal surfaces.

Rectify any paint defects if required.

5

NOTES:

- Repeat this step on both sides of the vehicle if required.
- Left-side shown; right-side similar.

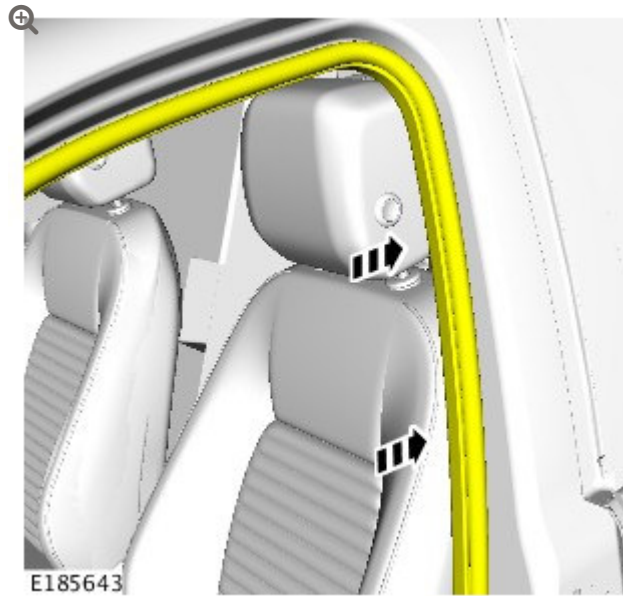

Install the front door aperture seal to the door aperture.

-
- 6 Road test the vehicle.
- If the noise **cannot** be heard, return the vehicle to the Customer. Confirm with the Customer that the originally reported noise has been rectified, a further road test with the Customer may be required.
 - If the noise **can** still be heard continue to the **Repair for Noises from Door Apertures** service instruction.

REPAIR FOR NOISES FROM DOOR APERTURES

¹ **NOTES:**

- Repeat this step on both sides of the vehicle if required.
- Left-side shown; right-side similar.

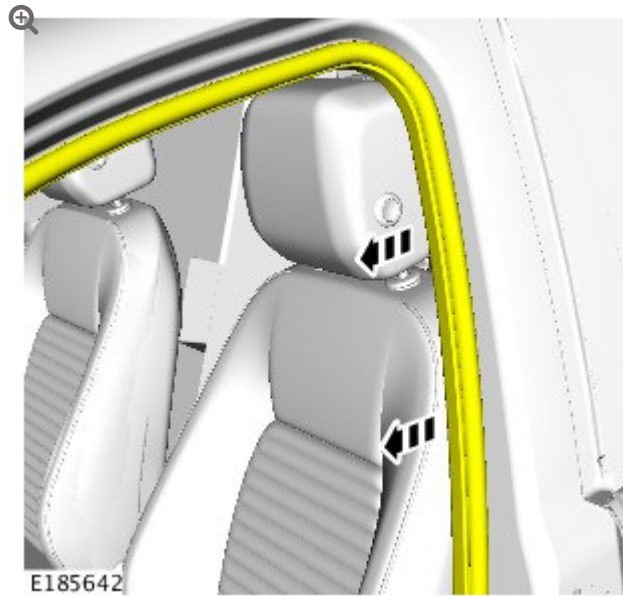

Move aside the front door aperture seal from the door aperture.

2

NOTES:

- Repeat this step on both sides of the vehicle if required.
- Left-side shown; right-side similar.



Move aside the rear door aperture seal from the door aperture.

3

CAUTION:

Using any other type of suitable tool may cause damage to the vehicle.

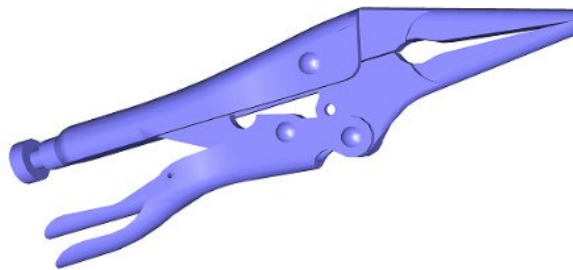

E206085

Only use the type of suitable tool shown when completing step 4.

4

CAUTIONS:

- Make sure no damage is caused to the vehicle.
- Make sure the surrounding area and the suitable tool are protected to avoid damaging the vehicle.
- Any body panels which have been modified/alterd must be returned to their original manufacturing condition.

NOTES:

- Repeat this step on both sides of the vehicle if required.
- Left-side shown; right-side similar.
- If necessary, refer to Body Repairs (see TOPIx workshop manual section 501-25A: Description and Operation - Body repairs) for further information on body panel repairs.

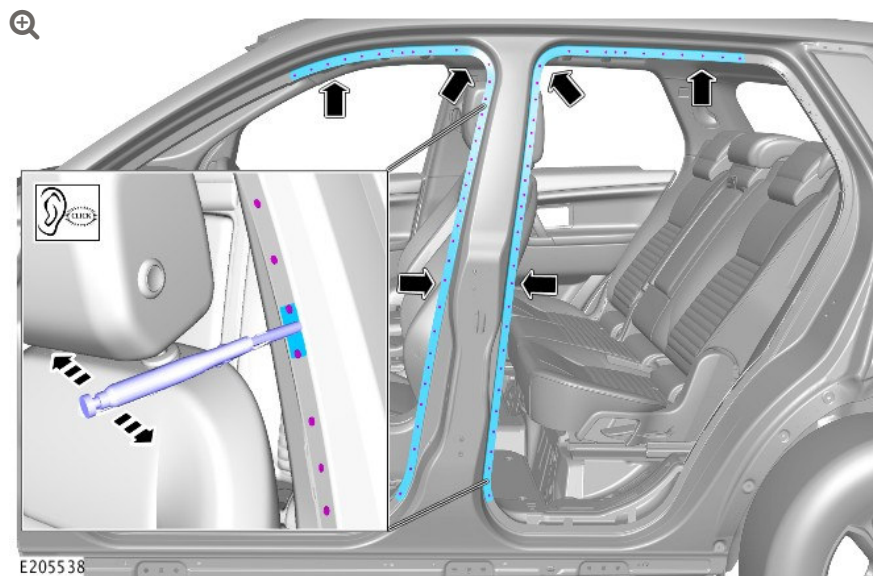

Move the panels, around the door apertures, first inwards and then outwards, as shown until any audible click can no longer be heard.

- Complete this step to the areas highlighted.
- This will eliminate the noise from this area.

5

CAUTION:

Make sure a locally sourced zinc-rich primer is applied to any bare metal surfaces.

Rectify any paint defects if required.

6

NOTES:

- Repeat this step on both sides of the vehicle if required.
- Left-side shown; right-side similar.



Install the rear door aperture seal to the door aperture.

7

NOTES:

- Repeat this step on both sides of the vehicle if required.
- Left-side shown; right-side similar.

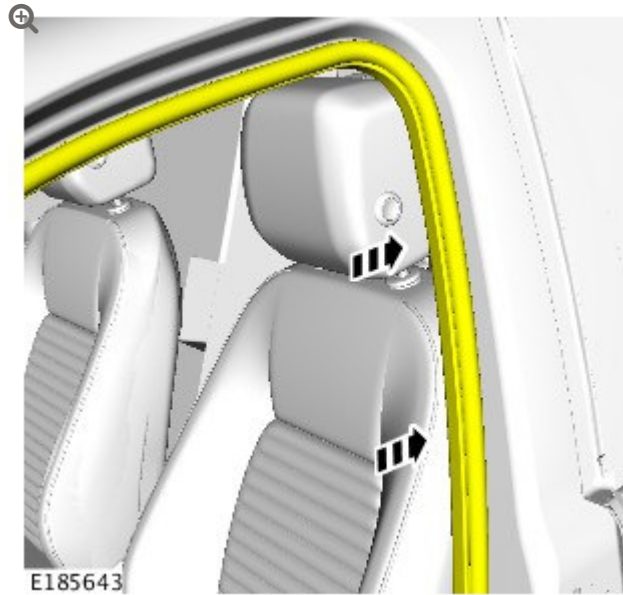

Install the front door aperture seal to the door aperture.

8 Road test the vehicle.

- If the noise **cannot** be heard, return the vehicle to the Customer. Confirm with the Customer that the originally reported noise has been rectified, a further road test with the Customer may be required.
- If the noise **can** still be heard continue to the **Repair for 'A' Pillar Front Header Panel** service instruction.

REPAIR FOR 'A' PILLAR FRONT HEADER PANEL

1 **NOTE:**

Right-side shown; left-side similar.

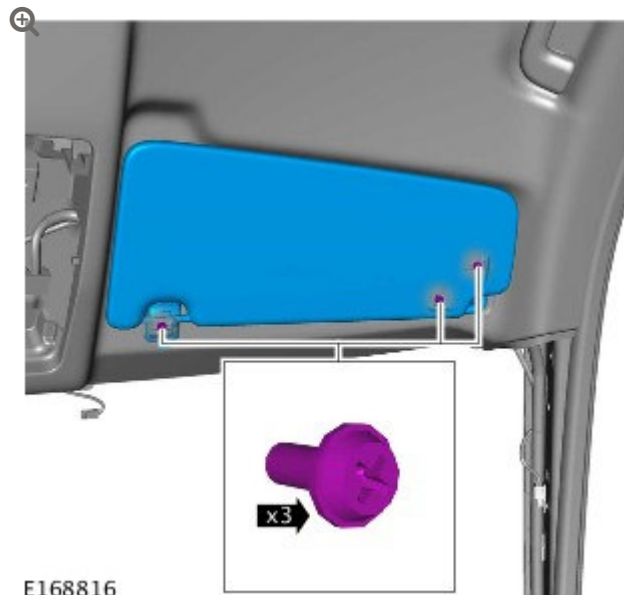

Remove the 3 bolts and remove the sun visor.

2 **CAUTION:**

Do not use a punch which has a point as this will damage the vehicle.

NOTE:

Right-side shown; left-side similar.

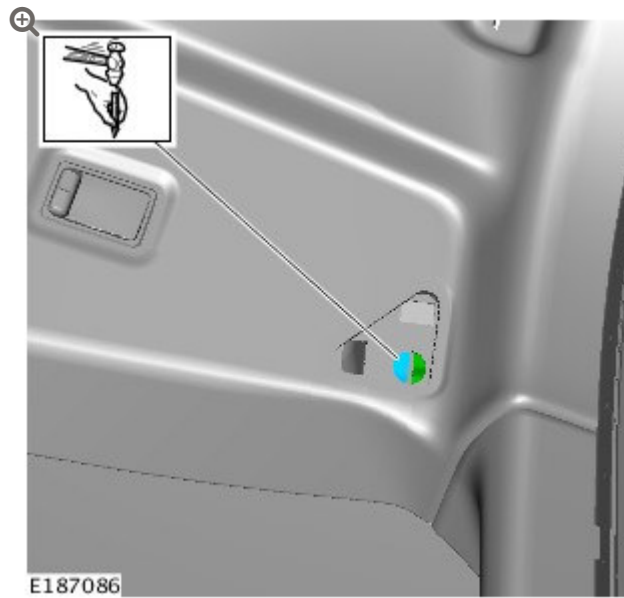

Insert a parallel pin punch with a minimum diameter of 16mm, through the sun visor bracket aperture.

- 1 Use a hammer to strike the punch in an upward motion several times to allow the panels to be distorted away from the sun visor bracket aperture.
 - This will eliminate the noise from this area.

3

NOTE:

Right-side shown; left-side similar.

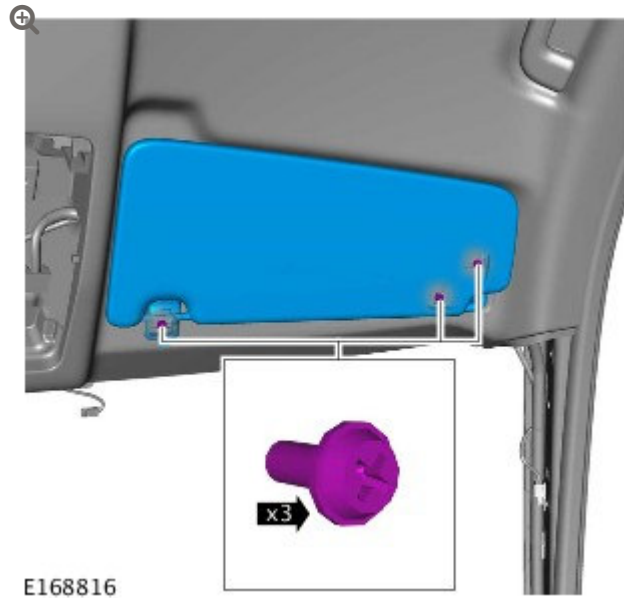

Install the sun visor and tighten the 3 bolts.

- Torque: **9Nm**.

↳ Road test the vehicle.

- If the noise **cannot** be heard, return the vehicle to the Customer. Confirm with the Customer that the originally reported noise has been rectified, a further road test with the Customer may be required.
- If the noise **can** still be heard continue to the **Repair for 'B' Pillar Spot Weld** service instruction.

REPAIR FOR 'B' PILLAR SPOT WELD

¹ **NOTES:**

- Repeat this step on both sides of the vehicle if required.
- Left-side shown; right-side similar.

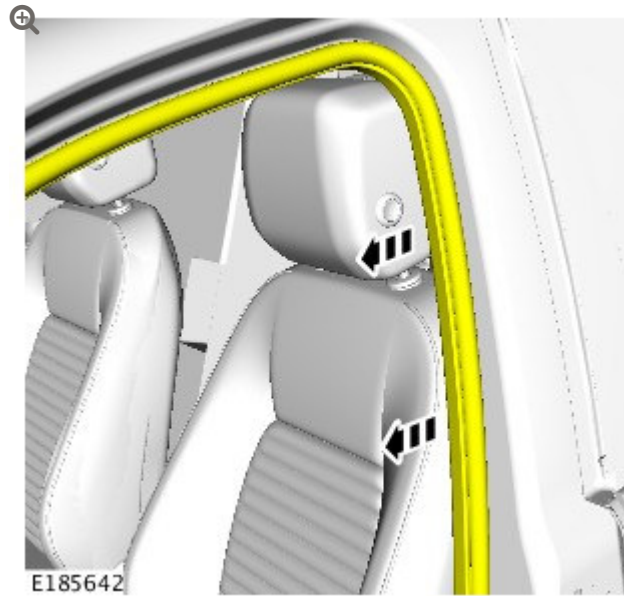

Move aside the front door aperture seal from the door aperture.

2

CAUTIONS:

- Use suitable welding blankets to protect the vehicle from any damage before continuing with this service instruction.
- Any body panels which have been modified/altered must be returned to their original manufacturing condition.

NOTES:

- Spot welding is the only approved method for this repair.

- Paint the area that has been spot welded.
- Repeat this step on both sides of the vehicle if required.
- The measurement shown may vary slightly from vehicle to vehicle.
- Left-side shown; right-side similar.
- If necessary, refer to Body Repairs (see TOPIx workshop manual section 501-25A: Description and Operation - Body repairs) for further information on body panel repairs.

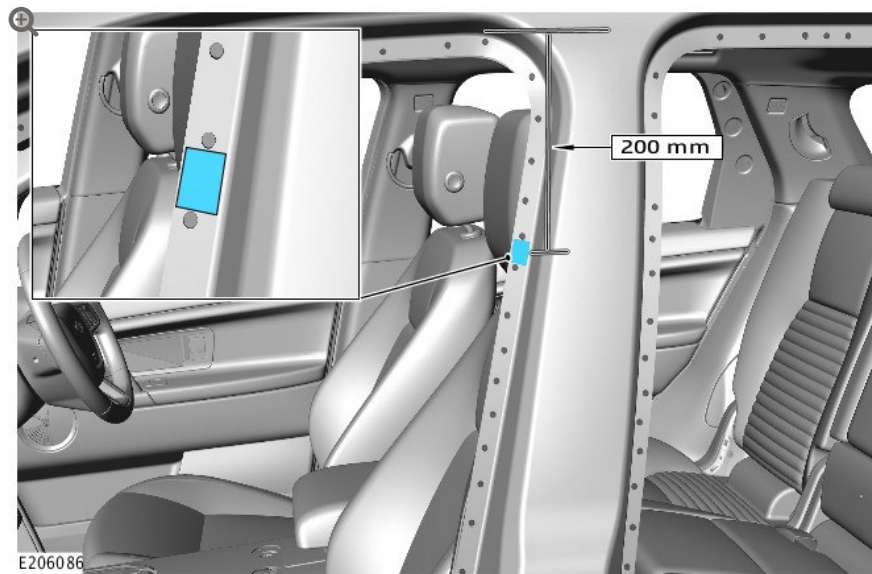

Place a single spot weld within the highlighted area shown.

- This will eliminate the noise from this area.

3

CAUTION:

Make sure a locally sourced zinc-rich primer is applied to any bare metal surfaces.

Rectify any paint defects if required.

4

NOTES:

- Repeat this step on both sides of the vehicle if required.
- Left-side shown; right-side similar.

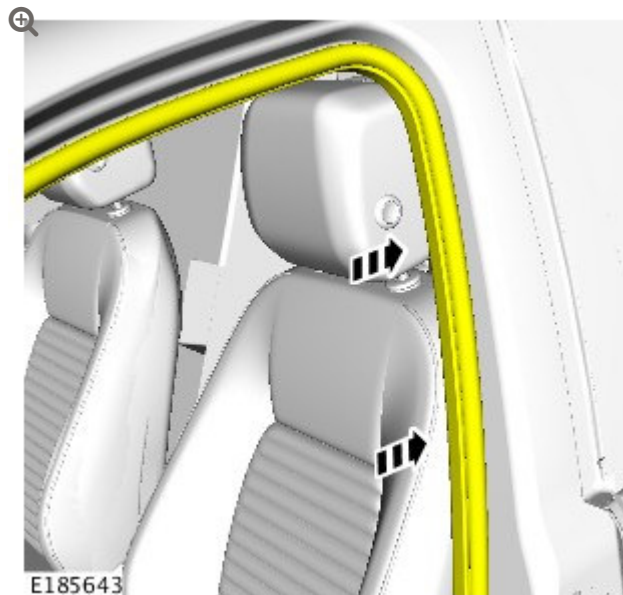

Install the front door aperture seal to the door aperture.

5 Road test the vehicle.

- If the noise **cannot** be heard, return the vehicle to the Customer. Confirm with the Customer that the originally reported noise has been rectified, a further road test with the Customer may be required.
- If the noise **can** still be heard continue to the 'Repair for Seatbelt Anchor' service instruction.

REPAIR FOR SEATBELT ANCHOR

1

NOTE:

This service instruction is only applicable vehicles up to VIN 638999. Do not complete this service instruction on vehicles from VIN 639000.

Remove the 'B' pillar upper trim (see TOPIx Workshop Manual section 501-05: Interior Trim and Ornamentation - 'B' pillar Upper Trim Panel).

2

CAUTION:

Any body panels which have been modified/altered must be returned to their original manufacturing condition.

NOTES:

- Do not drill to a depth of more than 6mm as this can damage the outer body.
- Make sure the seatbelt retractor bolt is in place and has been torque checked to 40Nm before fitting rivets
- Right-side shown; left-side similar.

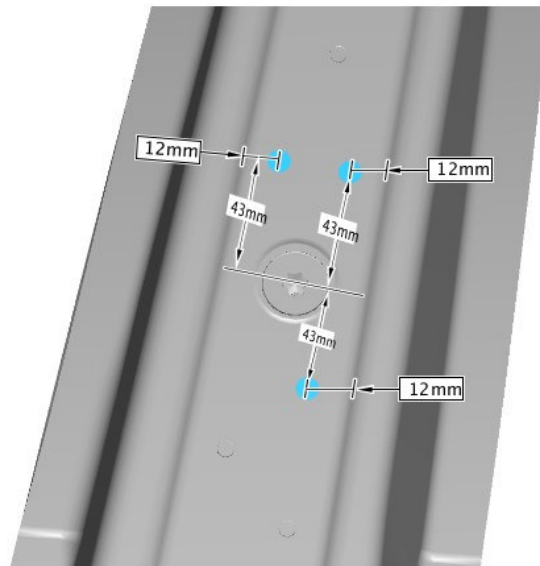

E197160

Drill 3 6.5mm diameter holes in the areas shown to a depth of 6mm.

- This will eliminate the noise from this area.

3

CAUTION:

Make sure a locally sourced zinc-rich primer is applied to any bare metal surfaces.

Rectify any paint defects if required.

4

Install the new rivets.

5

Install the 'B' pillar upper trim (see TOPIx Workshop Manual section 501-05: Interior Trim and Ornamentation - 'B' pillar Upper Trim Panel).

6

Road test the vehicle.

- If the 'ticking' noise **cannot** be heard, return the vehicle to the Customer. Confirm with the Customer that the originally reported noise has

been rectified, a further road test with the Customer may be required.

- If the 'ticking' noise **can** still be heard continue to the **Repair for 'B' pillar Upper Panel 'Creak' Noise** service instruction.

REPAIR FOR 'B' PILLAR UPPER PANEL 'CREAK' NOISE

CAUTIONS:

- Make sure a locally sourced zinc-rich primer is applied to any bare metal surfaces.
- Any body panels which have been modified/altered must be returned to their original manufacturing condition.

NOTES:

- Any joints sealed during vehicle manufacturing must be sealed as part of the repair.
- If necessary, refer to Body Repairs (see TOPIx workshop manual section 501-25A: Description and Operation - Body repairs) for further information on body panel repairs.

-
- 1 Before commencing this procedure, make sure that you are aware of all Health and Safety requirements. For additional information, refer to: (See TOPIx Workshop Manual section 100-00: General Information - Health and Safety Precautions).
-

2

CAUTIONS:

- Use suitable welding blankets to protect the vehicle from any damage before continuing with this bulletin.
- Make sure no damage is caused to any part of the vehicle.

Remove the side air curtain module (see TOPIx Workshop Manual section 501-20: Supplemental Restraint System - Side Air Curtain Module).

3

NOTE:

Left-side shown; right-side similar.



Identify the 3 spot welds to be drilled.

4

CAUTION:

Make sure no damage is caused to any part of the vehicle.

NOTES:

- Repeat this step on both sides of the vehicle.
- Left-side shown; right-side similar.

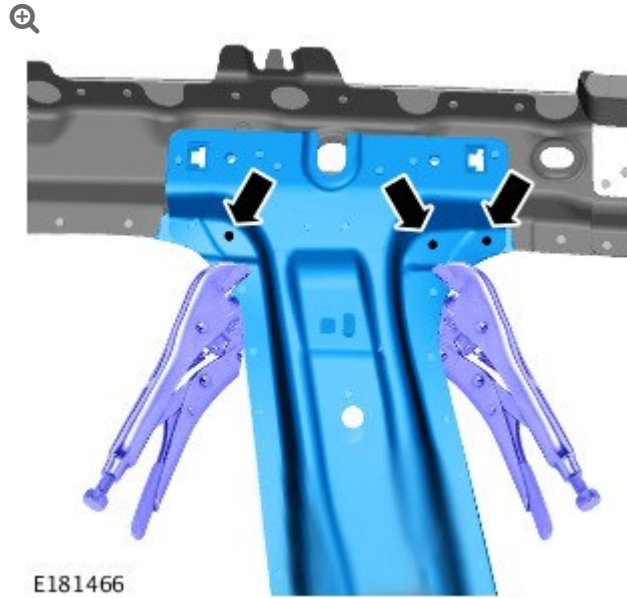

Make sure that when installing the suitable tools to clamp the 'B' pillar the spot welds that are to be drilled remain visible.

5**CAUTION:**

Make sure no damage is caused to any part of the vehicle.

NOTES:

- Repeat this step on both sides of the vehicle.
- Left-side shown; right-side similar.

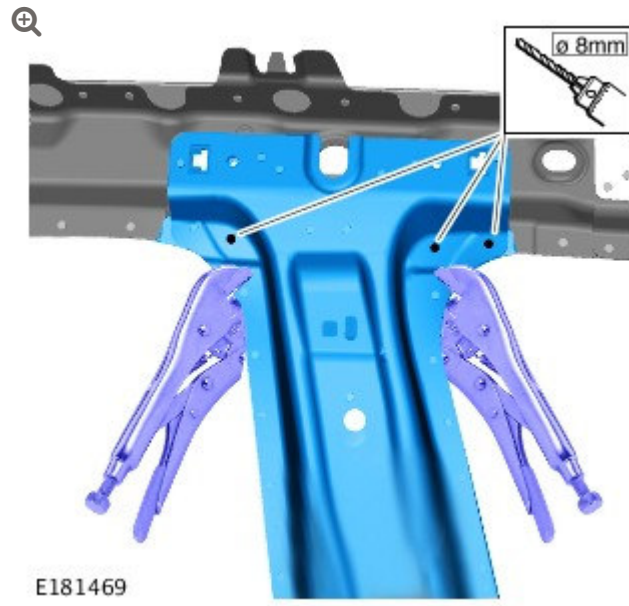

Drill the 3 spot welds to the correct depth of 2.5mm.

6

CAUTION:

Make sure no damage is caused to any part of the vehicle.

NOTES:

- Repeat this step on both sides of the vehicle.
- Right-side shown; left-side similar.
- Make sure corrosion protection is applied to all areas affected by the repair.

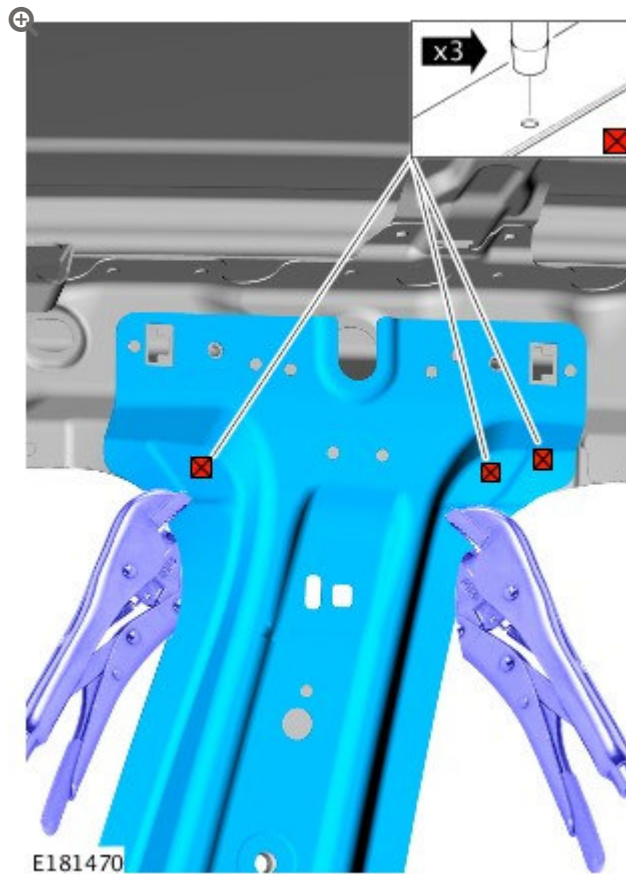

Metal Inert Gas (MIG) weld the 3 drilled holes.

7

CAUTION:

Make sure no damage is caused to any part of the vehicle.

NOTES:

- Repeat this step on both sides of the vehicle.
- Right-side shown; left-side similar.
- Make sure corrosion protection is applied to all areas affected by the repair.

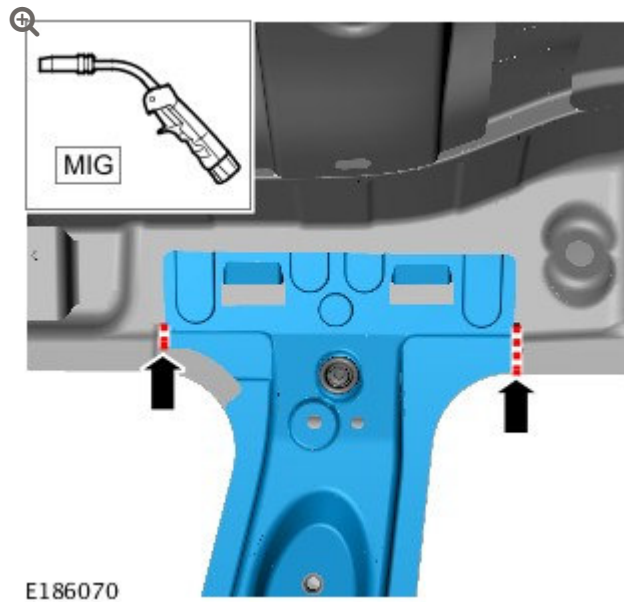

MIG seam weld the 'B' pillar in the area shown. This will eliminate the noise from this area.

- Make sure the area between the 'B' pillar and the inner 'B' pillar is completely MIG welded in the area shown.

8

CAUTION:

Make sure no damage is caused to any part of the vehicle while grinding.

NOTES:

- Repeat this step on both sides of the vehicle.
- Right-side shown; left-side similar.
- Make sure corrosion protection is applied to all areas affected by the repair.

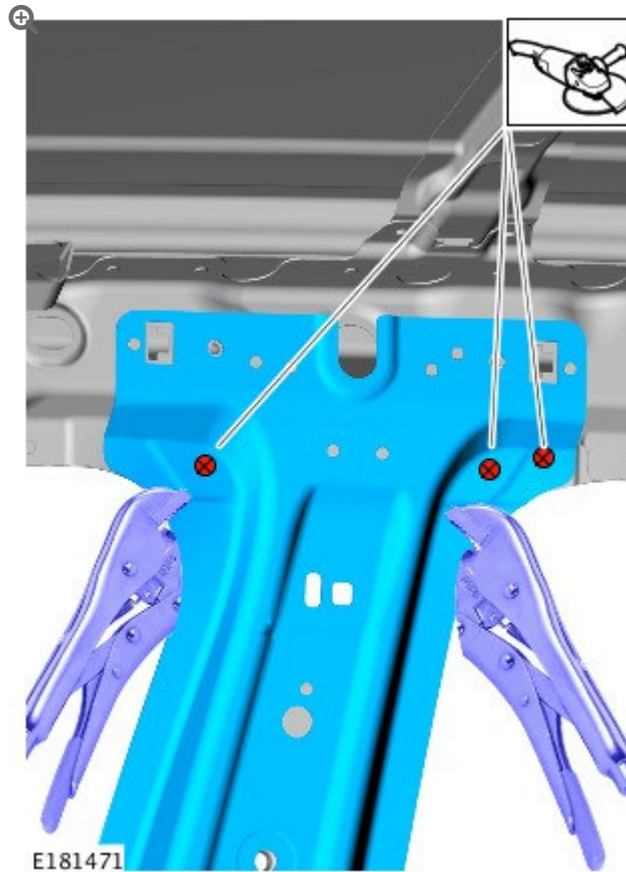

Grind away any excess material where the vehicle has been MIG welded.

9

CAUTION:

Make sure no damage is caused to any part of the vehicle.

NOTES:

- Repeat this step on both sides of the vehicle.
- Left-side shown; right-side similar.

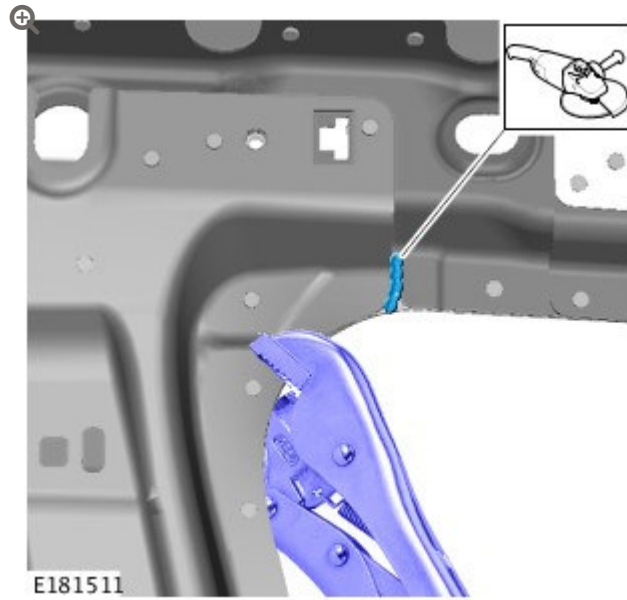

Grind away any excess material where the vehicle has been MIG welded.

10

CAUTION:

Make sure no damage is caused to any part of the vehicle.

NOTES:

- Repeat this step on both sides of the vehicle.
- Left-side shown; right-side similar.
- Make sure corrosion protection is applied to all areas affected by the repair.

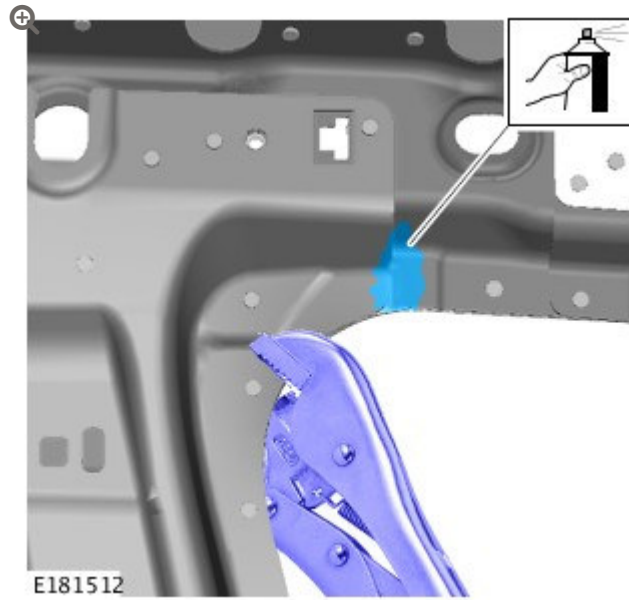

Use a suitable corrosion protection to cover the repaired area.

11

CAUTION:

Make sure no damage is caused to any part of the vehicle.

NOTES:

- Repeat this step on both sides of the vehicle.
- Right-side shown; left-side similar.
- Make sure corrosion protection is applied to all areas affected by the repair.

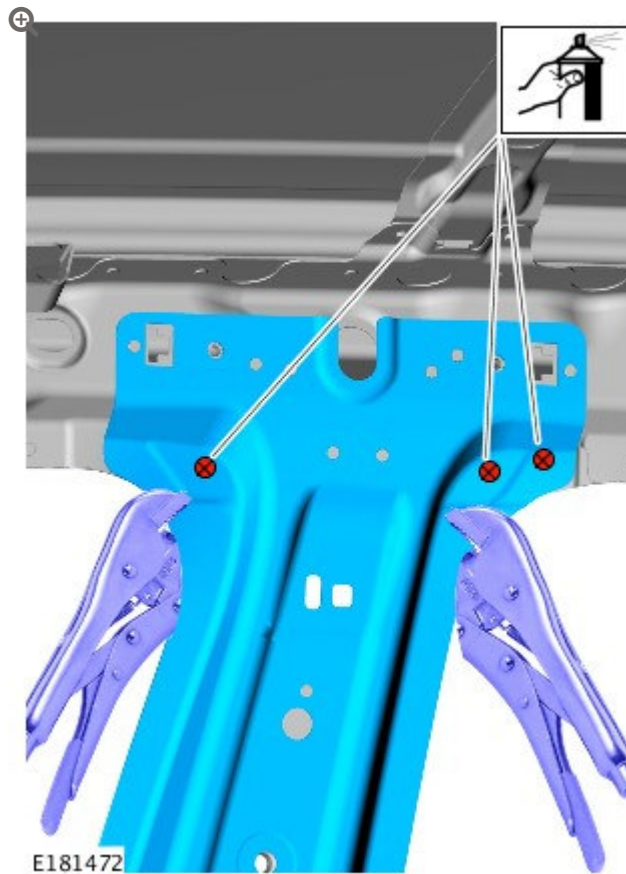

Use a suitable corrosion protection to cover the repaired area.

-
- 12 Install the side air curtain module (see TOPIx Workshop Manual section 501-20: Supplemental Restraint System - Side Air Curtain Module).
-
- 13 Road test the vehicle.
- If the noise **cannot** be heard, return the vehicle to the Customer. Confirm with the Customer that the originally reported noise has been rectified, a further road test with the Customer may be required.
 - If the noise **can** still be heard, raise a Technical Assistance (TA) with supporting documents such as photos and videos where applicable.

