 HYUNDAI NEW THINKING. NEW POSSIBILITIES. Technical Service Bulletin	GROUP FUEL SYSTEM	NUMBER 17-FL-002
	DATE MARCH 2017	MODEL VELOSTER (FS) SONATA HYBRID (YF HEV)
SUBJECT: CANISTER INSPECTION AND REPAIR (WARRANTY EXTENSION TXX9)		

Description:

Some Veloster (FS) and Sonata Hybrid (YF HEV) vehicles may experience a check engine warning light ON with any of the following DTCs found stored:

- P0442 - Evaporative System (EVAP) - Small Leak
- P0455 - Evaporative System (EVAP) - Large Leak
- P0456 - Evaporative System (EVAP) - Very Small Leak

This bulletin provides the service procedure to inspect vehicles for a potential crack found at the evaporative canister insert nuts:

- ***If crack is confirmed at the canister insert nut.*** Replacement Canister Kit, Bolts (and a Nut for Veloster) as listed in the Parts Information table (pages 2-3) are to be installed.
- ***If crack is not found at canister insert nut.*** Bracket Kit (includes bracket bolts & rubber washers) and Bolt Kit (and a nut for Veloster) as listed in the Part Information table (page 2) are to be installed. **NOTE: This repair will prevent a future canister crack incident, but also diagnose for other potential evap system leaks that may be root causes of the DTC.**

Applicable Vehicles:	Certain 2012-2016MY Veloster (FS) and 2011-2015MY Sonata Hybrid (YF HEV) (excluding Salt Belt States of Alaska, Connecticut, Delaware, Illinois, Indiana, Iowa, Kansas, Kentucky, Maine, Maryland, Massachusetts, Michigan, Minnesota, Missouri, Nebraska, North Dakota, New Hampshire, New Jersey, New York, Ohio, Pennsylvania, Rhode Island, South Dakota, Utah, Vermont, West Virginia, Wisconsin, and the District of Columbia)
-----------------------------	--







Warranty Information:

The canister warranty has been extended to 10 years from the date of original retail delivery or date of first use, or 120,000 miles, whichever occurs first. This warranty extension is valid for original and subsequent owners of the applicable vehicles. Follow the information outlined in this bulletin regarding the warranty extension details.

- For vehicles with “Open Campaign” status for Campaign 948, refer to the information outlined in TSB 17-01-003-1.

Model	Op Code	Operation	Op Time	Causal Part	Nature Code	Cause Code
Veloster (FS)	31410F00	CANISTER INSPECTION AND REPLACEMENT	0.8 M/H	31410-2V501FFF	I3T	ZZ3
	31410F01	CANISTER INSPECTION AND REPAIR		31420-2V509FFF		
Sonata Hybrid (YF HEV)	31410F02	CANISTER INSPECTION AND REPLACEMENT	0.9 M/H	31410-4R501FFF or 31410-4R701FFF		
	31410F03	CANISTER INSPECTION AND REPAIR		31450-4R509FFF		





SUBJECT:**CANISTER INSPECTION AND REPAIR**➤ **Canister Kit is Installed If Crack Is Confirmed In the Vehicle's Current Canister:****Note:** Order 1 of each item listed for the vehicle's MY/Model.

Model	Quantity/ Part Number	Description	Photo
Veloster (FS)	1 qty. of 31410-2V501FFF	Canister Kit	
	3 qty of 11251-08206BFFF	Bolt	
	1 qty. of 13385-08007KFFF	Nut	
11-12MY Sonata Hybrid (YF HEV)	1 qty. of 31410-4R501FFF	Canister Kit	
	2 qty of 11254-08206KFFF	Bolt	
13-15MY Sonata Hybrid (YF HEV)	1 qty. of 31410-4R701FFF	Canister Kit	
	2 qty of 11254-08206KFFF	Bolt	

Parts Information:

- **Bracket Kit is Installed If Canister Crack Is Not Found During Inspection:**

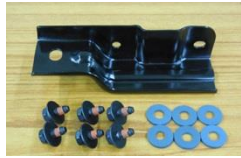
Note: Order quantity of each part as indicated:

Model	Quantity/ Part Number	Description	Photo
Veloster (FS)	1 qty. of 31420-2V509FFF	Bracket Kit	
	3 qty of 11251-08206BFFF	Bolt	
	1 qty. of 13385-08007KFFF	Nut	
Sonata Hybrid (YF HEV)	1 qty. of 31450-4R509FFF	Bracket Kit	
	2 qty of 11254-08206KFFF	Bolt	

Service Procedure:

- **Veloster (FS):** - Refer to **pages 4 to 10** of this TSB.
- **Sonata Hybrid (YF HEV):** - Refer to **pages 11 to 14** of this TSB.

Veloster (FS) Service Procedure

Removing The Canister For Crack Inspection:

1. Lift the vehicle on a hoist.
2. Remove the complete assembly of canister (A), air filter (B), and both attached brackets as a whole assembly from the vehicle for easier ability to perform inspection and repair.

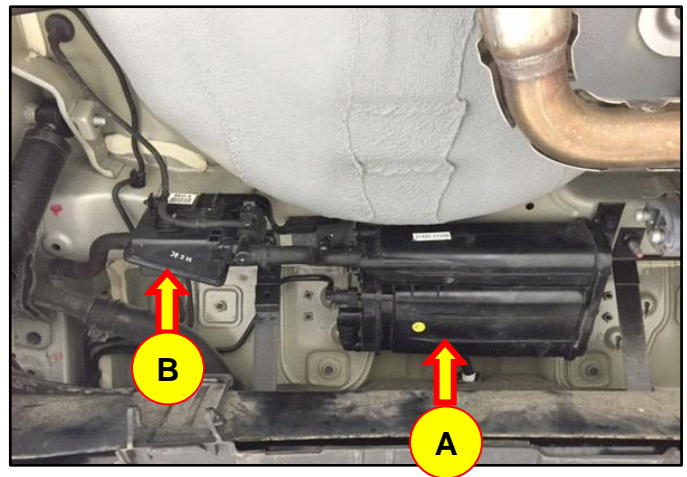

Canister, filter and brackets shown removed as a complete assembly from the vehicle.

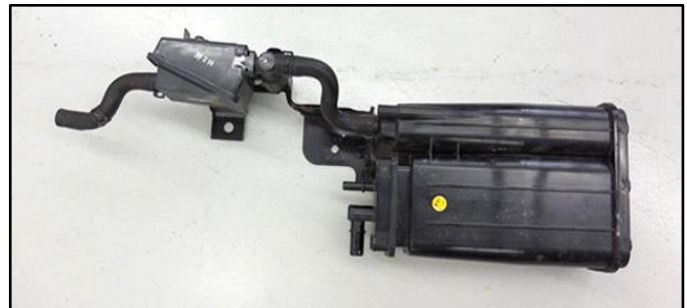

3. Remove the mounting bolts from the canister's lower and upper brackets. **Veloster** has 4 bolts total to remove.

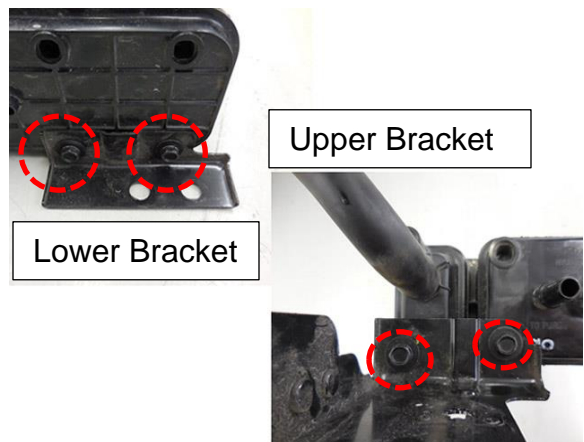

4. Clean the rust / foreign material from the insert nut surfaces by using a steel brush.
5. Blow out inside and around the insert nuts by using an air gun for 5 seconds.

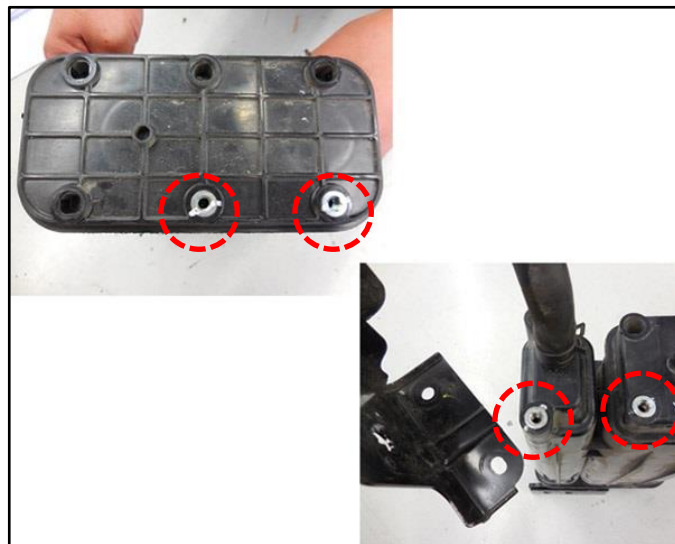

6. Inspect for any crack(s) found at the canister insert nut surfaces or in the surrounding plastic at the bottom and top of the canister.

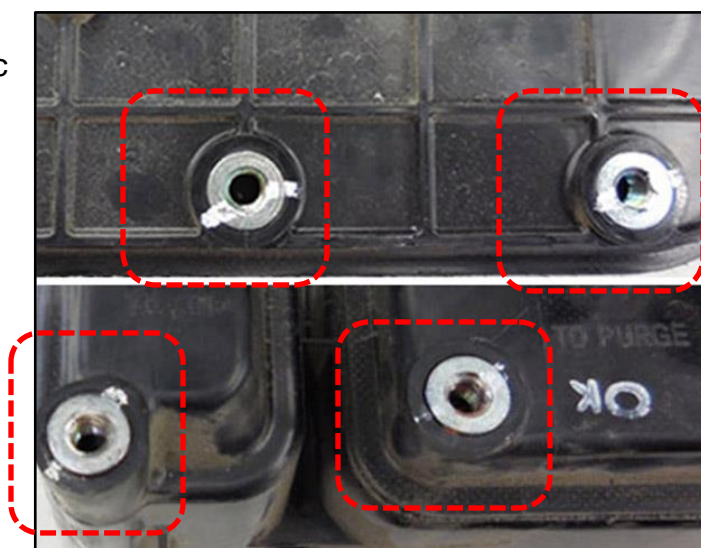

Examples of cracks found at the insert nut (C) or in the surrounding plastic.

NOTICE

The cracks may be very fine. Use a magnifying glass if available.

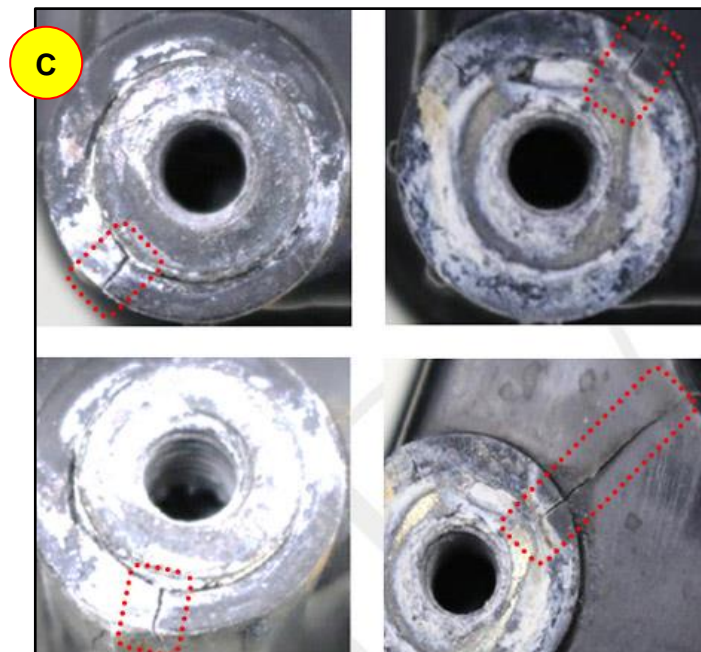

Repair Action if the Canister Inspection Did Not Find Any Crack:

- **NOTE:** If a crack was confirmed on the canister, do not perform the procedures in this section (steps 1-4). Proceed to page 9 of this TSB entitled: **Repair Action If Canister Crack Was Confirmed**

1. Install the rubber washer(s) (D), loctite applied bolts (E), and new lower bracket (F) of the Bracket Kit.

Carefully align the rubber washers to the 2 insert nut holes.

Tightening Torque

4.9 ~ 5.9 Nm

(0.5 ~ 0.6 kgf.m, 3.6 ~ 4.3 lb-ft)

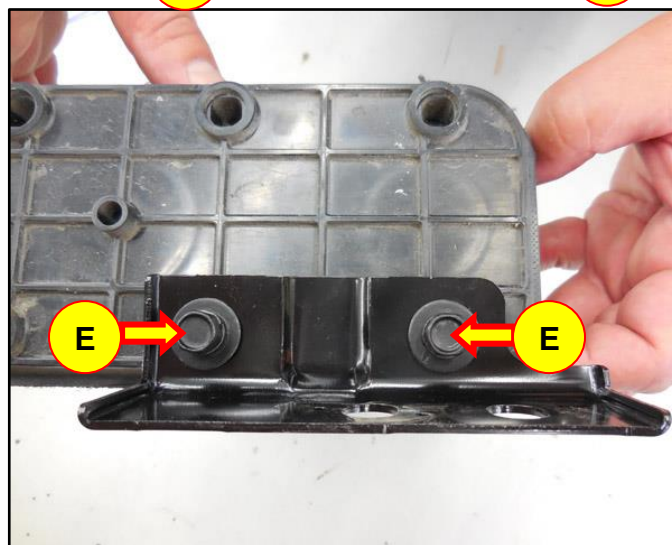
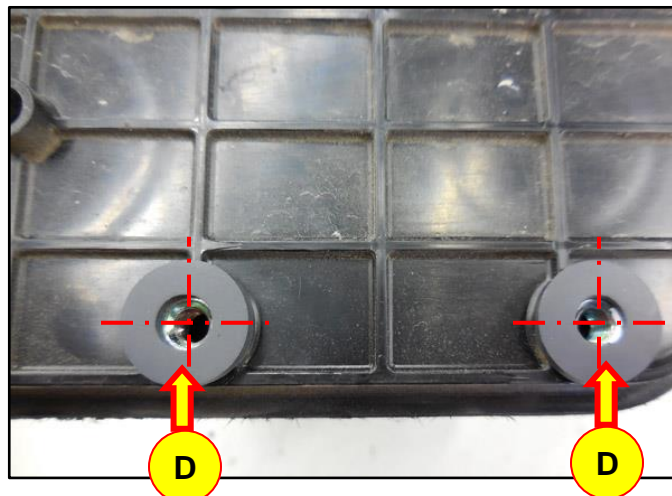

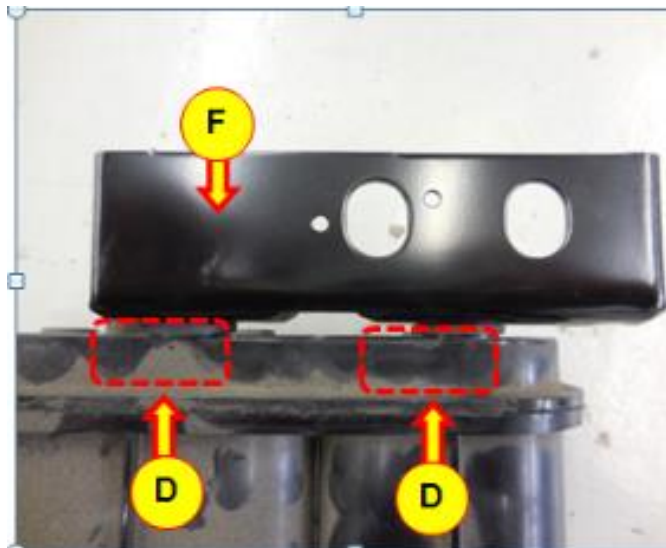

2. Install the Upper Bracket (G) using washer(s) and bolt(s) found within the Bracket Kit.

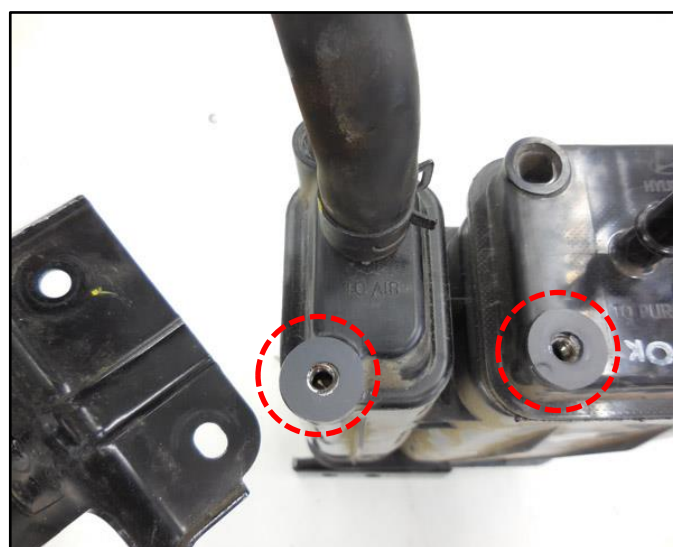

Tightening Torque
 4.9 ~ 5.9 Nm
 (0.5 ~ 0.6 kgf.m, 3.6 ~ 4.3 lb-ft)

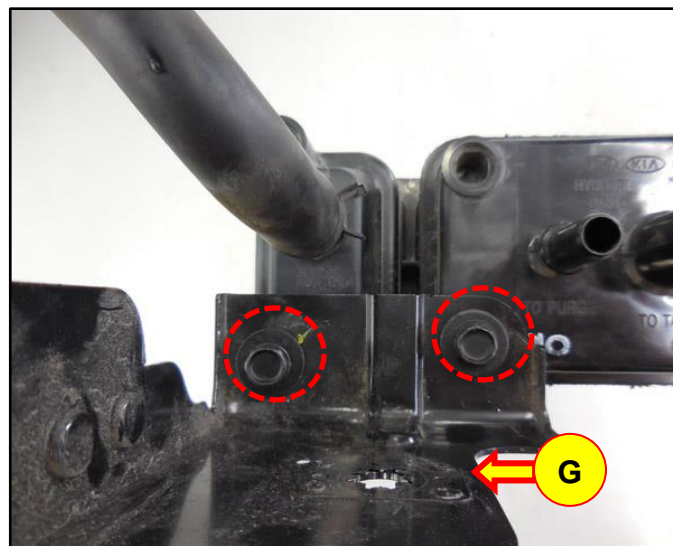

3. Install canister back to the upper bracket, apply spray of anti-corrosion wax to the areas as shown.

NOTICE

Anti-corrosion wax is applied to:
 - Whole side around (H) & (J)
 - Upper side of bolt and bracket (I).

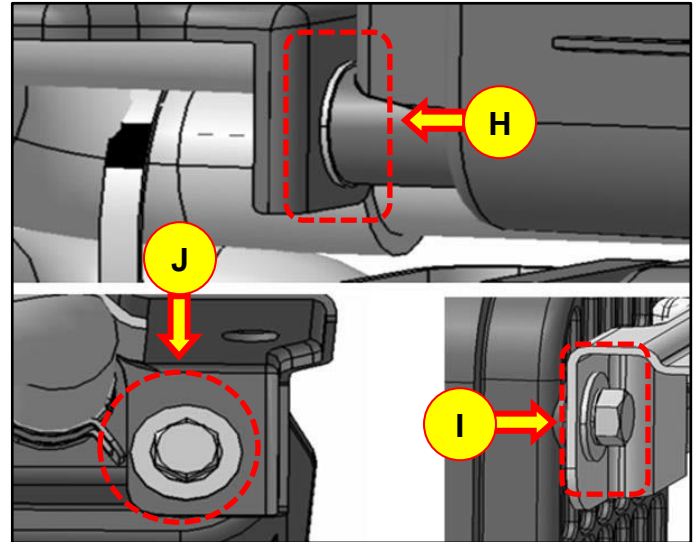

Recommended Anti-Corrosion Wax in the Hyundai Chemical program commonly used in other repairs:

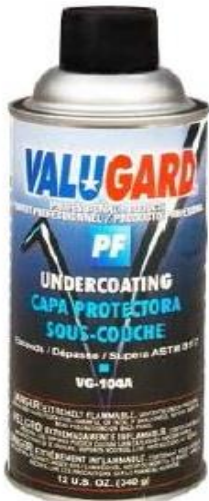

Undercoating Aerosol

Product Features and Benefits

- Remains flexible and will not peel or flake off
- Quick drying and low odor

Part Number	Container Size	Package Units	Campaign
00232-19035	12.0 oz	4	TT1, TT2, 058, 089, 090, 091, 113, 115, 924, 925

4. Reinstall all removed parts in reverse order of removal.

Tightening Torque

(Vehicle body side bolts):

21.6 ~ 32.4 Nm

(2.2 ~ 3.3 kgf.m, 15.9 ~ 23.9 lb-ft)



5. Skip to GDS checks at bottom of Page 9.

Veloster (FS) Service Procedure (Continued):**Repair Action If Canister Crack Was Confirmed:**

1. Replace the canister with correct Canister Kit and Bolts as shown in the Parts Information section. Install in reverse order of removal.

**NOTICE**

- Reuse the existing brackets from the vehicle.
- Be sure to transfer the protective metal shield from the old canister to the new canister.

General Evap Installation:

- Be sure to prevent dirt from entering inside the evap hoses or between the hoses and the points they connect to. This may cause an evap leak that can result in triggering DTCs after the repair.
- Inspect for dirt on the nipples and interior of the hose at connection points. If dirt is present, clean with a lint free rag.
- Prevent dirt entry or damage to the o-rings at quick connect fittings.

GDS Checks After Bracket Kit Or Canister Kit Have Been Installed:

1. Erase Engine DTC if any found.
2. For FS Veloster perform the **GDS Evap Leakage Test** (shown on next page) if conditions as indicated on GDS are met.
3. If conditions are met, run the test to confirm no leak found.
4. If leak test fails with leak found:
 - a. Inspect for and remove any debris caught between hoses and the points they attach to.
 - b. Inspect for hoses that may have been damaged.
 - c. Confirm that hoses are secure.
 - d. Continue to diagnose for other possible causes according to service manual diagnosis.

GDS Evap Leakage Test Procedure:

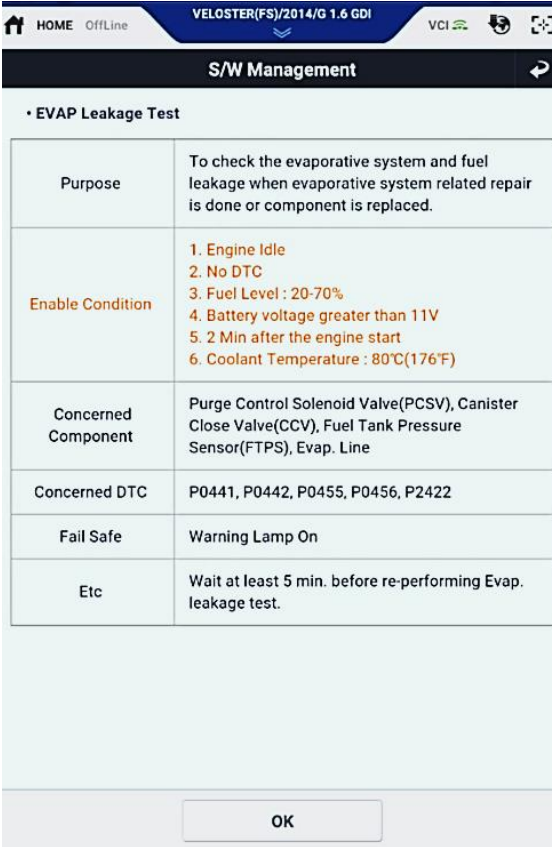
1. 

S/W Management

• EVAP Leakage Test

Purpose	To check the evaporative system and fuel leakage when evaporative system related repair is done or component is replaced.
Enable Condition	<ol style="list-style-type: none"> 1. Engine Idle 2. No DTC 3. Fuel Level : 20-70% 4. Battery voltage greater than 11V 5. 2 Min after the engine start 6. Coolant Temperature : 80°C(176°F)
Concerned Component	Purge Control Solenoid Valve(PCSV), Canister Close Valve(CCV), Fuel Tank Pressure Sensor(FTPS), Evap. Line
Concerned DTC	P0441, P0442, P0455, P0456, P2422
Fail Safe	Warning Lamp On
Etc	Wait at least 5 min. before re-performing Evap. leakage test.

OK

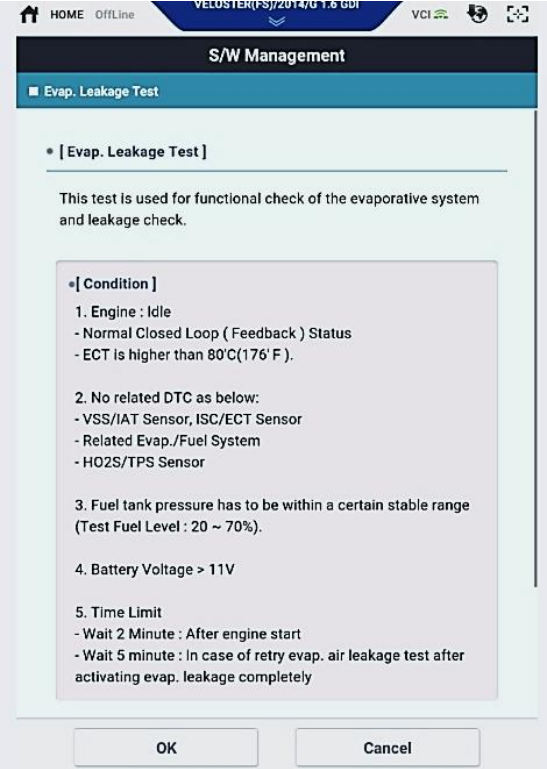
2. 

S/W Management

■ Evap. Leakage Test

• [Evap. Leakage Test]

This test is used for functional check of the evaporative system and leakage check.

• [Condition]

1. Engine : Idle
 - Normal Closed Loop (Feedback) Status
 - ECT is higher than 80°C(176° F).
2. No related DTC as below:
 - VSS/IAT Sensor, ISC/ECT Sensor
 - Related Evap./Fuel System
 - HO2S/TPS Sensor
3. Fuel tank pressure has to be within a certain stable range (Test Fuel Level : 20 ~ 70%).
4. Battery Voltage > 11V
5. Time Limit
 - Wait 2 Minute : After engine start
 - Wait 5 minute : In case of retry evap. air leakage test after activating evap. leakage completely

OK Cancel

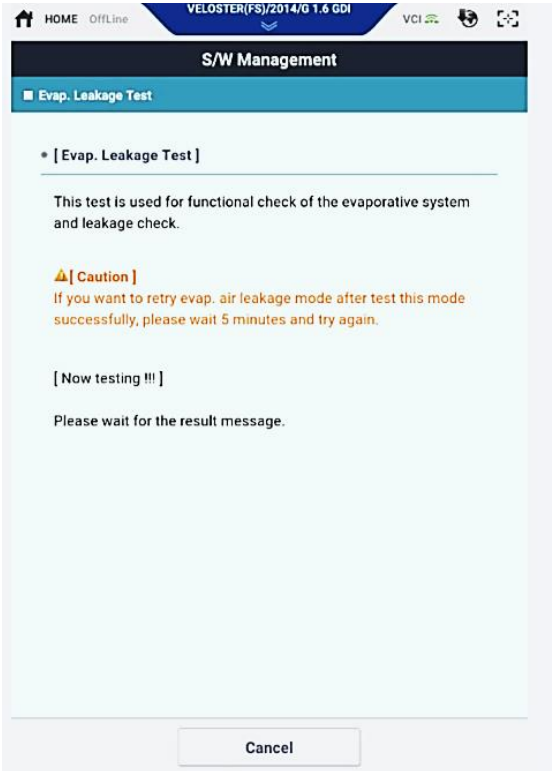
3. 

S/W Management

■ Evap. Leakage Test

• [Evap. Leakage Test]

This test is used for functional check of the evaporative system and leakage check.

⚠ [Caution]
If you want to retry evap. air leakage mode after test this mode successfully, please wait 5 minutes and try again.

[Now testing !!!]

Please wait for the result message.

Cancel

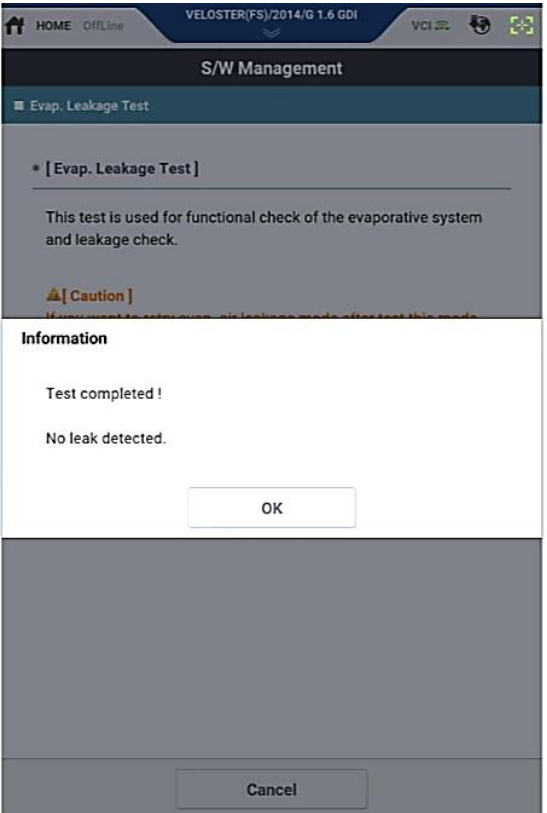
4. 

S/W Management

■ Evap. Leakage Test

• [Evap. Leakage Test]

This test is used for functional check of the evaporative system and leakage check.

⚠ [Caution]
If you want to retry evap. air leakage mode after test this mode successfully, please wait 5 minutes and try again.

Information

Test completed !

No leak detected.

OK

Cancel

Sonata Hybrid (YF HEV) Service Procedure:**Removing The Canister For Crack Inspection:****1. For ALL Sonata Hybrid (YF HEV):**

- i. Lift the vehicle on a hoist.
- ii. Disconnect the rear muffler from the 2 hangers as shown. Using a transmission jack, support the rear muffler and slowly lower to gain access to the canister assembly.



- iii. Remove the 4 bolts from the rear stabilizer bar (sway bar) from the rear cross member.

➤ For 2011-2012MY continue to step 2.

➤ For 2013-2015MY skip to step 4.

**2. 2011-2012MY YF HEV:**

Remove the complete canister assembly with NVLD, brackets, and hose as shown.

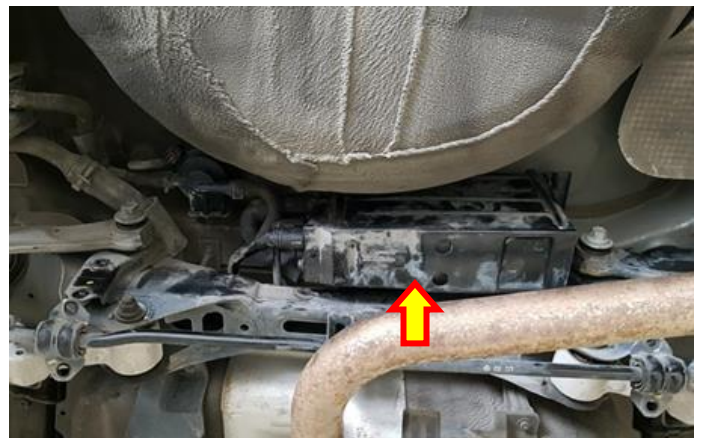

2011-2012MY YF HEV canister, NVLD, bracket and hose shown removed as a complete assembly from the vehicle.

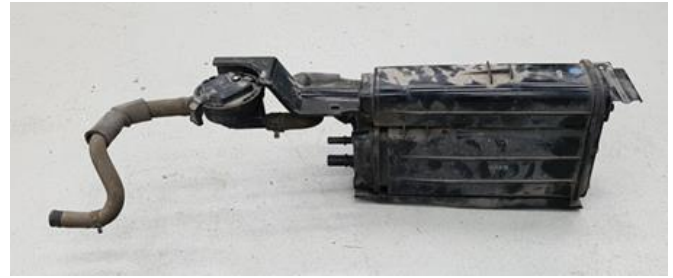

- 3. Remove the 6 mounting bolts from the canister lower and upper brackets.

For 2011-2012MY continue to step 6.

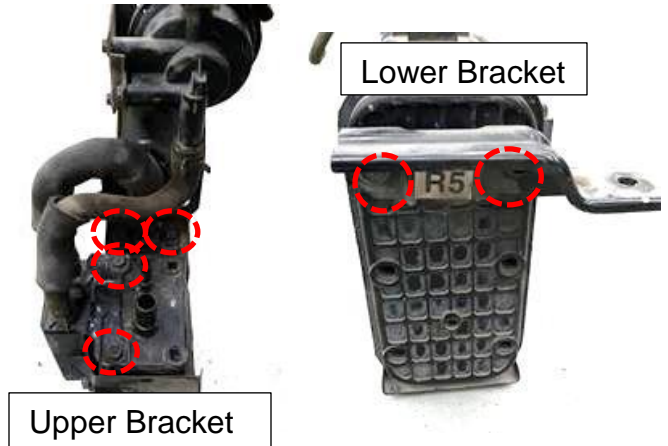

- 4. **2013-2015MY YF HEV Special Procedure:**

13-15MY vehicles have a different canister from 11-12MY vehicles. In 13-15MY, the complete canister assembly with NVLD, brackets and hose cannot be removed from the vehicle due to interferences at reinstallation of the canister.

Only the canister and its lower bracket as shown here can be removed from the vehicle for the inspection and repair procedures. The 4 bolts to the two upper brackets must be detached from the canister. The upper brackets are to be left in the vehicle.



- 5. With canister and its lower bracket removed from the car, remove the 2 mounting bolts from the canister lower bracket.



6. Clean the rust / foreign material from the insert nut surfaces by using a steel brush.
7. Blow out inside and around the insert nuts by using an air gun for 5 seconds.

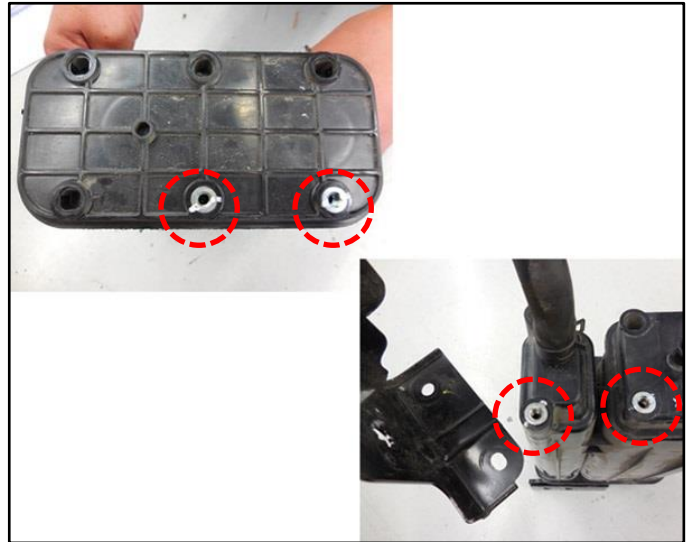

8. Inspect for any cracks at the canister insert nut surfaces or in the surrounding plastic at the bottom and top of the canister.

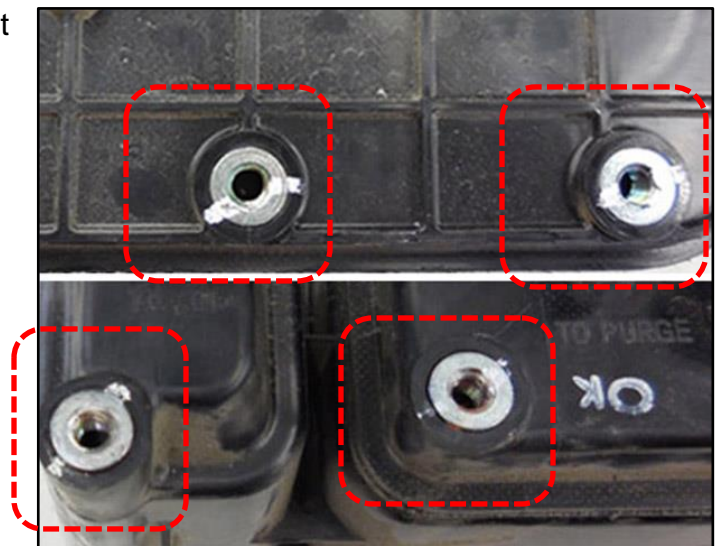

Examples of cracks found at the insert nut (C) or in the surrounding plastic.

NOTICE

The cracks may be very fine. Use a magnifying glass if available.

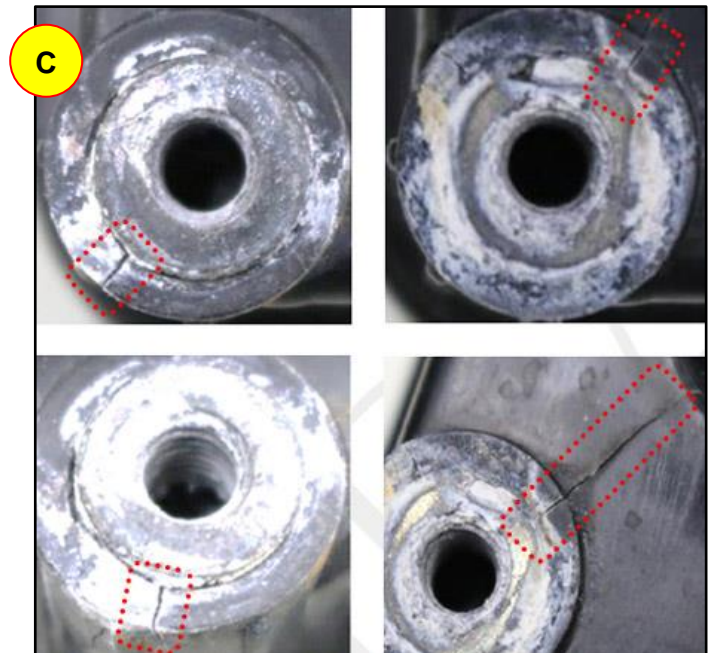

➤ **Repair Action if YF HEV Canister Inspection Did Not Find Any Crack:**

The YF HEV Canister repair with no cracks found after inspection is similar to the Veloster (FS) Canister repair with exception of the IMPORTANT note below for 2013-2015MY. Reference pages 6 to 8 of this TSB.

IMPORTANT

2013-2015MY YF HEV Special Instructions

The 2 Upper Brackets that were not removed with the Canister should be left in the vehicle. Attach them to the canister when the canister is installed back to the vehicle **but be sure to include the rubber washers.**

Applying a light coating of fast drying glue to rubber washers to hold them aligned with the canister will make it much less difficult to reinstall the canister back to the upper brackets in the car.

➤ **Repair Action If YF HEV Canister Crack Was Confirmed:**

Replace the canister with correct Canister Kit Bolts and Nut as shown in the Parts Information section. Reuse the existing brackets from the vehicle.



YF HEV Installation (both repair cases):

NOTICE

- Sway bar install torque: **44.1 ~ 53.9 Nm (4.5 ~ 5.5 kgf.m, 32.5 ~ 39.8 lb-ft)**

General Evap Installation:

- Be sure to prevent dirt from entering inside the evap hoses or between the hoses and the points they connect to. This may cause an evap leak that can result in triggering DTC(s) after the repair.
- Inspect for dirt on the nipples and interior of the hose at connection points. If dirt is present, clean with a lint free rag.
- Prevent dirt entry or damage to the o-rings at quick connect fittings.

- After repair, erase engine DTC if any found. GDS Evap Leak test is not required.