

REFERENCE:	Nova Bus Manuals
SECTION:	04: Front Suspension
RS N°:	N/A
EFFECTIVE IN PROD.:	N/A

APPLICATION DEADLINE: N/A

SUBJECT:	Hub Carrier Kit (Middle Axle)
JUSTIFICATION:	Introduction of optimized hub carrier kit for ZF AVN-132 middle axle on 60' vehicles.

LEVEL	DESCRIPTION	DIRECT CHARGES		TIME
		LABOUR	MATERIAL	
1	New part number for the modified hub carrier.	-	-	-
2	-	-	-	-

MATERIAL

QTY	PART N°	REV.	DESCRIPTION	REPLACES PART N°
LEVEL 1				
2	N8902913	-	HUB CARRIER REPAIR KIT	N8895941
LEVEL 2				
-	-	-	-	-

DISPOSAL OF PARTS

REMOVED PARTS ARE:	DISCARDED	RETAINED	
	-	-	

REVISION HISTORY

REV.	DATE	CHANGE DESCRIPTION	WRITTEN BY
NR	2017AL27	Initial release	Kumaraswamy K S

CLIENT	ORDER	ROAD NUMBER		VIN (2NVY/4RKY...)		QTY
		FROM	TO	FROM	TO	
Ames Transportation Agency - Iowa	L707	660	661	S92U5C4500159	S92U1C4500160	2
Ames Transportation Agency - Iowa	L904	6101	6104	S92J1G9775221	S92J7G9775224	4
Austin - CMTA - Texas	L635	5001	5001	S92U7C4500163	S92U7C4500163	1
Austin - CMTA - Texas	L636	5002	5022	S92U1D4500306	S92U0D4500328	21
Clemson Area Transit - South Carolina	L617	—	—	S92U5C4500002	S92U5C4500002	1
Clemson Area Transit - South Carolina	L769	—	—	S92U1D4500418	S92U1D4500418	1
CT Transit - Connecticut	L554	1041	1065	S92U1A4000139	S92U0A4000164	25
CT Transit - Connecticut	L571	1101	1110	S92YXB4000144	S92Y4B4000169	10
CT Transit - Connecticut	L814	1462	1473	S92LXE4500717	S92L4E4500728	12
CT Transit - Connecticut	L815	1426	1429	S92L0E4500709	S92L0E4500712	4
Demo - Articulated Bus	L433	—	—	S92UX93000029	S92UX93000029	1
Duke University - North Carolina	L651	—	—	S92Y1B4000145	S92Y3B4000146	2
Halifax - Nova Scotia	L558	717	731	S92UXA3000293	S92U6A3000307	15
Halifax - Nova Scotia	L613	732	741	S92UXB3000019	S92UXB3000028	10
Halifax - Nova Scotia	L708	742	761	S92UXC3000782	S92U3C3000803	20
Houston - Texas	L737	1510	1510	S92U4D4500297	S92U4D4500297	1
Houston - Texas	L755	1511	1579	S92U4D4500333	S92U8D4500402	69
Houston - Texas	L952	1580	1580	S92J5G9775318	S92J5G9775318	1
Houston - Texas	L982	1581	1599	S92J5G9775514	S92J5G9775545	19
LYNX - Florida	L725	—	—	S92Y9D4500329	S92Y5D4500330	2
LYNX - Florida	L764	—	—	S92Y7D4500331	S92Y9D4500332	2
LYNX - Florida	L785	—	—	S92L6E4500505	S92L8E4500506	2
MTD - Santa Barbara, California	L730	—	—	S92J8E4500567	S92J1E4500569	3
New York City Transit - New York	L536	1200	1201	S92U793000490	S92U993000491	2
New York City Transit - New York	L545	1202	1289	S92U5A4000001	S92U0A4000098	88
New York City Transit - New York	L643	5895	5895	S92U1B4000143	S92U1B4000143	1
New York City Transit - New York	L670	5770	5894	S92U9B4000147	S92UXC4500061	125
New York City Transit - New York	L681	5896	5283	S92U2C4500023	S92U9C4500195	122
New York City Transit - New York	L692	5284	5363	S92U3C4500158	S92U3D4500274	80
New York City Transit - New York	L958	5439	5442	S92J9G9775533	S92J9G9775631	4
New York Demo	L940	—	—	S92J7F4501257	S92J7F4501257	1
Niagara Falls - Ontario	L652	—	—	S92U3C3000607	S92U6C3000617	11
Niagara Parks Commission - Ontario	L685	—	—	S92U9C3000644	S92U8C3000652	9
San Joaquin County - California	L768	—	—	S92L4D4500422	S92L3D4500427	6
Saskatoon - Saskatchewan	L359	—	—	S92U583000289	S92U583000289	1
Saskatoon - Saskatchewan	L551	1005	1007	S92UXA3000178	S92U8A3000180	3
Saskatoon - Saskatchewan	L568	—	—	S92U9B3000013	S92U9B3000013	1
Saskatoon - Saskatchewan	L618	—	—	S92U1C3000377	S92U1C3000377	1
SEPTA - Pennsylvania	L724	7300	7301	S92Y1D4500275	S92Y3D4500276	2
SEPTA - Pennsylvania	L741	7355	7355	S92L4E4500504	S92L4E4500504	1
SEPTA - Pennsylvania	L742	7371	7414	S92L6E4500729	S92L7E4500772	44

CLIENT	ORDER	ROAD NUMBER		VIN (2NVY/4RKY...)		QTY
		FROM	TO	FROM	TO	
SEPTA - Pennsylvania	L743	7356	7370	S92L1E4500489	S92L2E4500503	15
SEPTA - Pennsylvania	L745	7415	7415	S92L0F4500873	S92L0F4500873	1
SEPTA - Pennsylvania	L746	7416	7454	S92L7F4500952	S92L8F4501012	39
SEPTA - Pennsylvania	L749	7302	7354	S92Y7D4500409	S92L2E4500470	53
SEPTA - Pennsylvania	L861	7300	7484	S92L5G9775188	S92L8G9775220	32
St. Catharines Ontario	L898	1560	1560	S92J4F3001663	S92J4F3001663	1
St. John - New Brunswick	L272	—	—	S92U483000011	S92U483000011	1
St. John - New Brunswick	L273	—	—	S92U383000050	S92U383000050	1
Toronto Transit Commission - TTC - Ontario	L729	9000	9000	S92U9D3000905	S92U9D3000905	1
Toronto Transit Commission - TTC - Ontario	L738	9001	9026	S92J6D3001094	S92J7D3001119	26
Toronto Transit Commission - TTC - Ontario	L777	9027	9152	S92J7E3001123	S92J6E3001372	126
University of Colorado - Colorado	L427	—	—	S92U693000027	S92U693000027	1
University of Colorado - Colorado	L428	—	—	S92U893000028	S92U893000028	1
University of Colorado - Colorado	L627	—	—	S92UXB4000139	S92U6B4000140	2
Walt Disney World - Florida	L763	—	—	S92U0D3001019	S92U4D3001024	6
York Regional Transit - Ontario	L562	1080	1082	S92U2A3000420	S92U6A3000422	3
York Regional Transit - Ontario	L572	1083	1094	S92U3A3000569	S92U2A3000580	12
York Regional Transit - Ontario	L654	1370	1390	S92U1D3000946	S92U2D3000986	21
York Regional Transit - Ontario	L761	1391	1396	S92U6D3001008	S92UXD3001013	6
York Regional Transit - Ontario	L964	1770	1774	S92J3G3750420	S92J0G3750424	5

**WARNING**

Follow your internal safety procedures.

PROCEDURE**NOTE**

The instructions included in this document have been provided by ZF. Nova Bus cannot be held responsible under any circumstances for the content of this procedure.

ANNEX - INTRODUCTION OF OPTIMIZED HUB CARRIER KIT FOR ZF AVN-132

File: 7
 Type: AVN-132
 Consecutive no.: 32/16e
 Date: 4/13/2016

Service Information



Unit/Type: AVN-132

Subassembly: Output, portal drive

Distribution: Various customers

I. Procedure and Purpose:

In our striving for continuous technical upgrading we optimized the casting outline on the hub carrier and the shield of the wheel bearing area in the output / portal drive.
 For the components involved please refer to page 2.

II. Validity and Actions:

Parts lists/Spare parts lists: see page 3

Modification introduced: as of unit no.: 3357000

Interchangeable: yes - only jointly

Complete units (on stock) update: yes no

Mounting new parts: possible
 if previous part failed
 at each unit assembly

Spare parts (on stock): use up
 rework
 return to ZF
 scrap

III. Documentation-Modification:

Spare parts list: correct handwritten

Further documentation:

IV. Urgency/Miscellaneous: - not applicable -

File: 7
 Type: AVN-132
 Consecutive no.: 32/16e
 Date: 4/13/2016
 Page 2/4

Service Information



to I. Procedure and Purpose

<u>Components involved</u>	<u>Previous</u>	<u>New</u>
2 hub carriers	4472.336.330	4472.336.505
2 plugs	----	0637.510.179
2 tapered plugs	----	0637.510.184

„Previous“



„New“

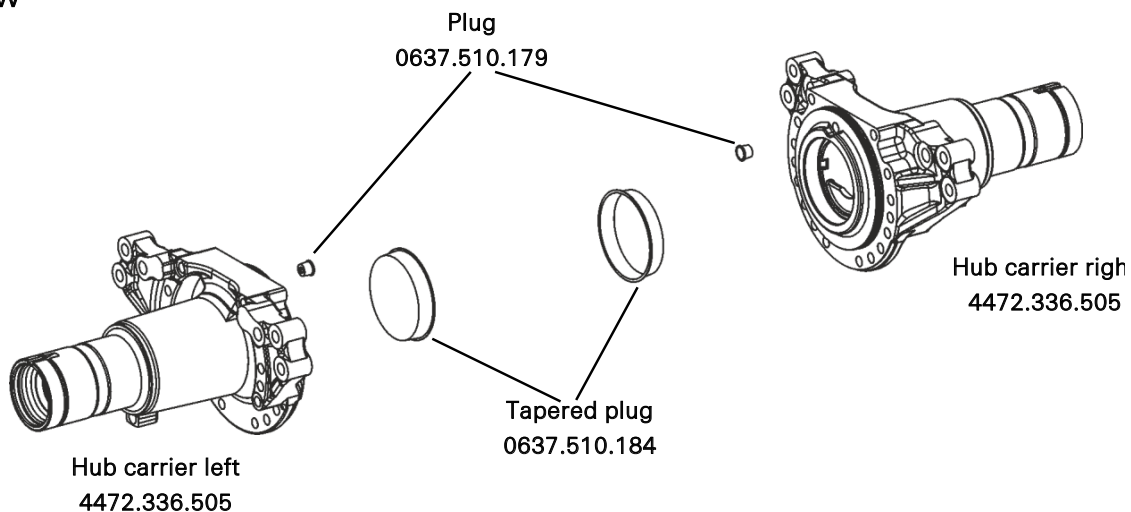

File: 7
Type: AVN-132
Consecutive no.: 32/16e
Date: 4/13/2016
Page 3/4

Service Information



Caution!

For detailed information regarding disassembly and reassembly please refer to the Repair Manual.

Assembly instructions:

It is not permitted to mix „Previous“ and „New“ components!

The installation of different hub carrier versions per output is possible.

When installing the new hub carrier, the new screen sheet must also be installed.

When using the new hub carrier 4472.336.505, tapered plug 0637.510.184 and plug 0637.510.179 must be installed!

Application of a pressure compensation hole at 6 o'clock position (approx. $\varnothing 5$ mm) into the plastic tapered plug (see subsequent sketch)!

Background: Because of the oil wall in the hub carrier there is a risk of potential water accumulation in the hub carrier in the most unfavourable case. Therefore the holes must be closed when using the new hub carrier in case of repair.

Perforation of the tapered plug 0637 510 184:

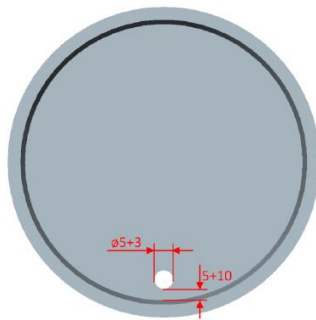

Installation of tapered plug 0637 510 184 with perforation at 6 o'clock position ($\pm 15^\circ$) into the hub carrier:

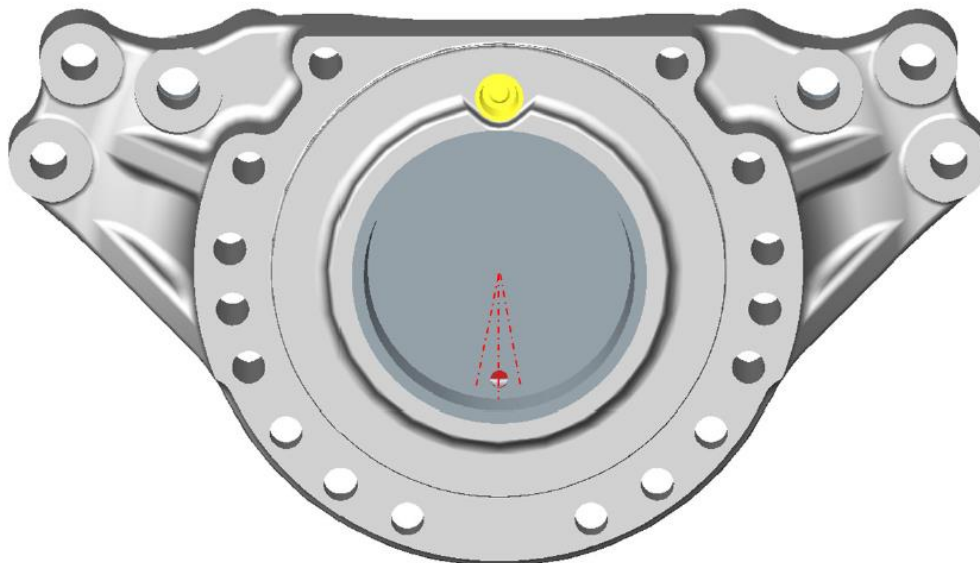

File: 7
Type: AVN-132
Consecutive no.: 32/16e
Date: 4/13/2016
Page 4/4

Service Information



to II. Validity - Actions

Parts lists / spare parts lists:

AVN-132 4472.036.070/077/119/213/247/248/337/350/357/396/429/438/445/454/477/482/
495/542/564/568/573/597/610/612/614/615/616/618/625/634/636/640/
642/649/650/656/666/667/668/670/679/680/681/683/684/685/686/689/
690/691/692/693/698/699/700/703/706/707/708/710/712/715/716/717/
718/720/721/722/723/724/725/726/729/730