

NEV-R-LUBE[®]

SEALED CARTRIDGE BEARING SYSTEM

\$ SAVE TIME, SAVE MONEY

- No more inner and outer bearing to repack
- Pre-lubricated and resistant to contamination
- Sealed for life, no bearing maintenance
- Increased durability and reliability
- No replacing seals when checking brakes
- Pre-set adjustment allows for easy installation
- Human error is virtually eliminated during adjustment
- Five year or 100,000 mile limited warranty

? WHAT IS NEV-R-LUBE[®]?

Dexter's Nev-R-Lube[®] bearings are comprised of opposed tapered roller bearing cones sealed inside of a precision ground, one-piece double cup arrangement. These bearings are designed with a small amount of axle end play. The end play is essential to the longevity of the bearing's service life. Nev-R-Lube[®] is not designed for immersion in water, such as boat trailer use.



\$ SPECIFICATIONS

42mm SEALED CARTRIDGE BEARINGS

- D52 and D60 leaf spring axles
- #11 and #12 Torflex[®] axles
- Straight spindles only
- Up to 6,000 lbs. capacity
- 6 on 5.50" bolt circle hub-drums
- 12" x 2" brakes
- Use only zero offset wheels

\$ NEV-R-LUBE[®]

SEALED CARTRIDGE BEARING SYSTEM



\$ SPECIFICATIONS

50mm SEALED CARTRIDGE BEARINGS

- D70, D72, and D80 leaf spring axles
- #12, #12V, and #13 Torflex[®] axles
- Straight spindles only
- Up to 8,000 lbs. capacity
- 8 on 6.50" bolt circle hub-drum
- 12" x 2", 12-1/4" x 3-3/8", and 12-1/4" x 2-1/2" brakes
- Can be used with zero to 1/2" inset wheels at 7,000 lb. ratings
- Zero offset or 0.19" inset wheels only at 8,000 lbs. capacity



NEV-R-LUBE[®] is subject to the maintenance and inspection procedures as specified in Dexter Axle's current publication, "Operation Maintenance Service Manual".



E-Z LUBE[®]

BEARING LUBRICATION SYSTEM

BEARING LUBRICATION MADE QUICK & EASY

- A trailer running gear lubrication system that's simple to maintain and completely submersible
- Allows grease to easily flow to both the inner and outer bearings for a complete repack
- No disassembly required, just attach a grease gun at the spindle end and inject the grease
- E-Z Lube[®] cap allows for easy access, extra protection, and virtually no mess
- Easily purges contaminated grease without removing the hub
- Ideal for most towable axles including boat trailer applications
- Five-year limited product warranty for sprung axles
- Ten-year limited product warranty for torsion axles

E-Z LUBE[®]
BEARING LUBRICATION SYSTEM

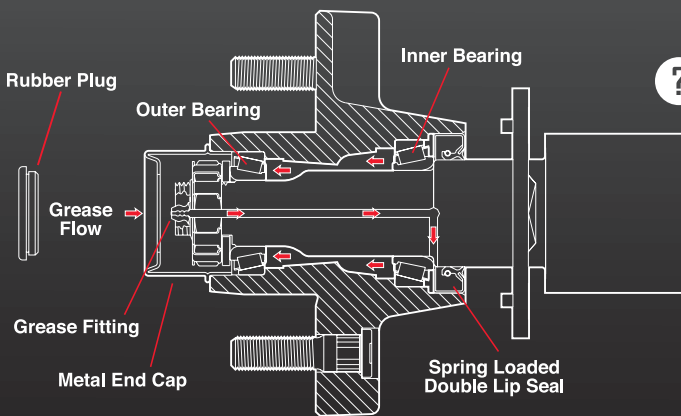
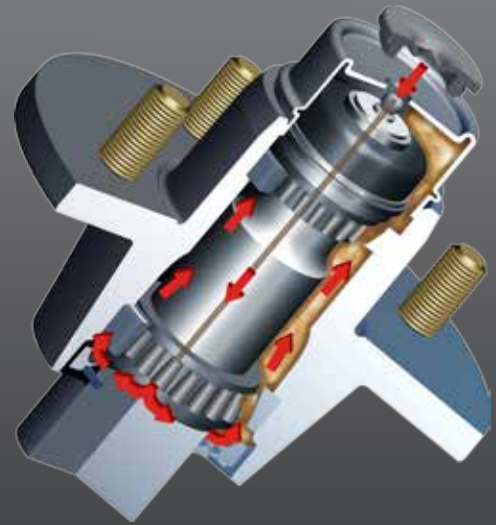

? WHAT IS E-Z LUBE[®]?

The E-Z Lube[®] system consists of axle spindles that have been specially drilled and assembled with grease fittings. When grease is pumped into the fittings, it is channeled to the inner bearing, then to the outer bearing, and eventually back out the grease cap hole for a complete bearing repack. The protection and maintenance features of the E-Z Lube[®] system make it ideal for most towable axles. E-Z Lube[®] is designed to allow for immersion in water.

E-Z Lube[®] is subject to the maintenance and inspection procedures as specified in Dexter Axle's current publication, "Operation Maintenance Service Manual".

Scan to view
E-Z Lube[®] Video

