



## On-Road

### GL1800/A

## Trunk Lock Remote Testing

When troubleshooting it is good to have all of the tools at your disposal. If you are diagnosing a power trunk lock remote control issue on a GL1800, there is a Honda tool that you may not know is capable of testing the trunk lock remote. The VT55 and VT36 TPMS testers have the option to check if the remote is transmitting properly. Here's how to test the remote transmitter.

1. Scroll through the main menu options on the tester and find *RKE Test*.



2. Select *Honda Motorcycle* and then *313 MHz*.



3. When the test screen comes up, press one of the buttons on the remote while holding it near the tester.

- If the remote is transmitting properly the tester will indicate *PASS* as shown.
- If the remote is not transmitting properly the battery or the remote control may need to be replaced.



### 2017 Grom125

## License Light Mounting

Due to the new fender design for model year 2017, the license light mounting structure allows for more "float" than other Honda models. The amount float is normal for this model and should not be changed or "tightened up." If a customer expresses concern or requests an "adjustment," inform them that the float is necessary to protect the socket and bulb from the effects of vibration.



## Mid-Year Design Change

During the model year 2017 Grom125 production run the clutch cover and dipstick were redesigned and, as a result, the dipstick was re-located toward the front of the cover. Early production units have the dipstick positioned near the back of the clutch cover. The oil level check procedure is the same as before. Please note that the dipsticks are not interchangeable. The new part numbers will be reflected in the June 2017 Web Parts Catalog update.

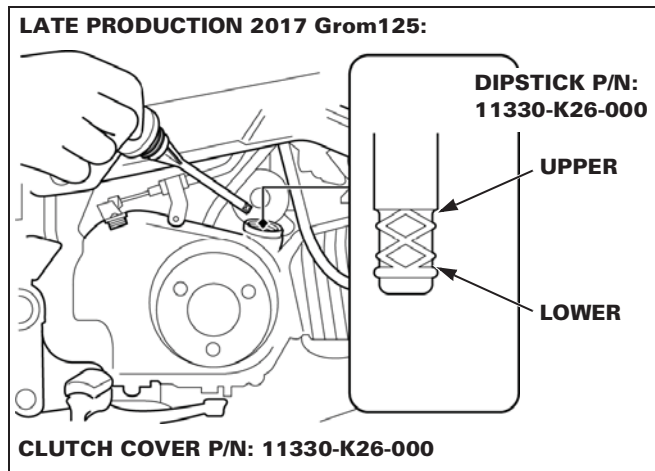

## Li-ion Battery Recycling

Starting with model year 2017, certain Honda powersports models will be equipped with a Lithium-ion (Li-ion) battery. When the original equipment battery expires, you are strongly encouraged to replace it with a Honda Genuine Part and recycle the expired battery, at no cost to your dealership, by following the battery recycling procedure outlined in the *iN Parts Bulletin #MPB 16275*.

### ***iN* > Parts > Parts Bulletins > Lithium-ion Battery Recycling Program**

Each Honda Genuine Parts Li-ion battery will be shipped within a large re-usable shipping container. This container will include a pre-paid FedEx return shipping label that will direct the package to American Honda's designated Li-ion battery recycler. Therefore it is important that you save all of the original packing material and FedEx shipping label from each Honda Genuine Parts Li-ion battery in your inventory.

## The Training Corner

### Spotlight on HondaPro Technical Training

Congratulations to **Mark Williams** at Honda of Melbourne in Melbourne, FL, who earned his HondaPro Red Level status this past winter. Presenting the award to Mark in the photo below is Honda District Service Manager, Denny Ray and the dealership's General Manager, Tony Otero.



During his recent visit to Honda of Melbourne, Denny had the opportunity to interview Mark:

- Q)** How has completing the HondaPro training helped you in your technical repair skills?
- A)** *I've gained better diagnostic skills and increased confidence.*
- Q)** How long did it take for you to achieve your RED Level status?
- A)** *I started Honda training at MMI in 2006, then completed four HondaPro advanced training courses while at this dealer.*
- Q)** What was the best part of attending HondaPro technical training?
- A)** *I liked the Individualized Skills Training, which allowed me to work at my own pace and progress through the modules quickly.*
- Q)** Has the training resulted in increased efficiency?
- A)** *Absolutely; I'm not sure exactly how much, I just know it is better.*
- Q)** Is there any advice you would like to share with other technicians?
- A)** *The HondaPro training is well worth the time and effort for both technicians and your dealership.*



©2017 American Honda Motor Co., Inc. All Rights Reserved. Published by: AHM Motorcycle Service Communications, 1919 Torrance Blvd., Torrance, CA 90501. All suggestions become the property of American Honda Motor Co., Inc. Sending a suggestion gives American Honda permission to publish it without further consideration. \*The information in this article is for authorized Honda PWC or MUV dealers only (applicable only if a PWC or MUV article is included in the issue).

Editor: Robert Heilbron E-mail *The Wrench* at [EditorTheWrench@ahm.honda.com](mailto:EditorTheWrench@ahm.honda.com)

MSN 16291 (1705)