

June 1, 2017

06636 Version 6

## Steering Column Screeches When Moving

Supersedes 14-031, dated October 5, 2016, to revise the information highlighted in yellow

### AFFECTED VEHICLES

Year	Model	Trim	VIN Range
2014–15	MDX	ALL	ALL
2016	MDX	AWD	5FRYD4H..GB000001 thru 5FRYD4H..GB060678
2016	MDX	2WD	5FRYD3H..GB000000 thru 5FRYD3H..GB020816
2014–16	RLX	ALL	ALL
2014, 2016	RLX Hybrid	ALL	ALL

### REVISION SUMMARY

Under AFFECTED VEHICLES, the 2014, 2016 RLX Hybrid was added.

### SYMPTOM

In high ambient temperatures, the steering column screeches or squeals when it moves in or out.

### POSSIBLE CAUSES

Premature wear of the steering column gearbox components.

### CORRECTIVE ACTION

Replace the steering column assembly.

### PARTS INFORMATION

Part Name	Part Number	Quantity
Steering Column (2014–15 MDX)	53200-TZ5-A52	1
Steering Column (2016 MDX)	53200-TZ5-A62	1
Steering Column (RLX, RLX Hybrid)	53200-TY2-A03	1
Driver's Knee Airbag Bolts (MDX)	90178-TZ5-003	4
Driver's Knee Airbag Bolts (RLX, RLX Hybrid)	90178-SNA-003	4
Steering Lock Kit (bracket and two left-hand thread bolts)	06352-TX4-A11	1
Steering Wheel Bolt	90161-TX4-000	1
Driver's Airbag Bolts	90134-S6A-A80	2

**CLIENT INFORMATION:** The information in this bulletin is intended for use only by skilled technicians who have the proper tools, equipment, and training to correctly and safely maintain your vehicle. These procedures should not be attempted by "do-it-yourselfers," and you should not assume this bulletin applies to your vehicle, or that your vehicle has the condition described. To determine whether this information applies, contact an authorized Acura automobile dealer.

## WARRANTY CLAIM INFORMATION

The normal warranty applies.

Operation Number	Description	Flat Rate Time	Template ID	Defect Code	Symptom Code	Failed Part Number
510100	Remove and replace the steering column. (2014–16 RLX) and (2014, 2016 RLX Hybrid)	1.1 hrs	14-031N	07409	04201	53200-TY2-A02
D	Add for alignment.	0.4 hr	14-031P			
510100	Remove and replace the steering column. (2014–15 MDX)	1.8 hrs	14-031Q	07409	04201	53200-TZ5-A51
D	Add for alignment.	0.4 hr	14-031R			
510100	Remove and replace the steering column. (2016 MDX)	1.8 hrs	14-031S	07409	04201	53200-TZ5-A61
D	Add for alignment.	0.4 hr	14-031T			

Skill Level: Repair Technician

## REPAIR PROCEDURE

1. Do the battery terminal disconnection procedure.
2. Remove the driver's airbag.
3. Remove the steering wheel.
4. Remove the driver's dashboard lower cover.
5. Remove the steering column cover.
6. Disconnect the combination switch connectors and remove the clip.

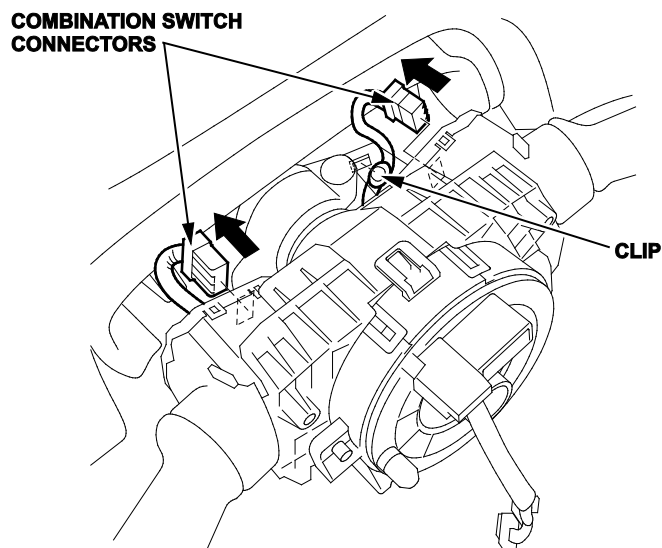

7. Remove the clips and disconnect the following connectors:

- Cable reel connectors
- Steering angle sensor connector
- (2014–15 models only): Electric steering lock connector
- Tilt/telescopic motors connector

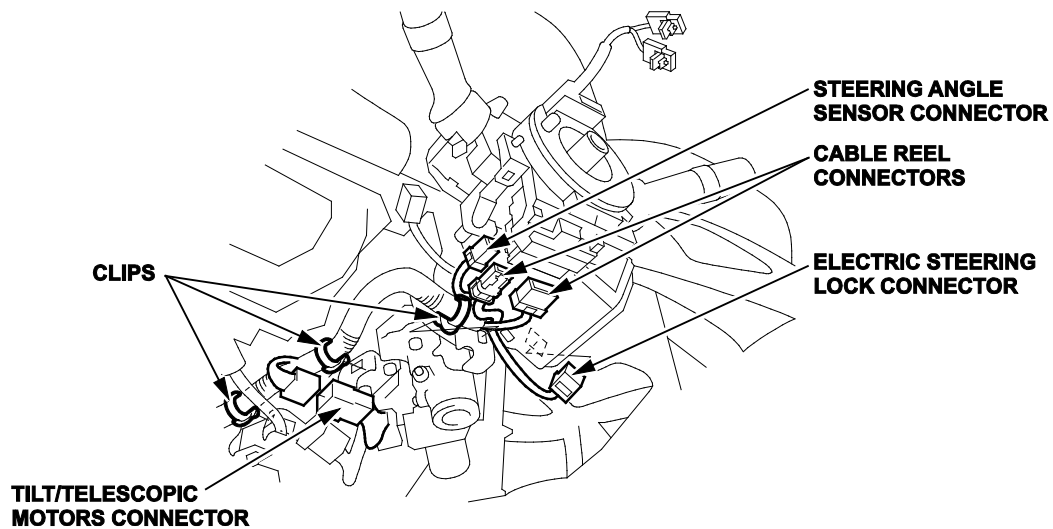

8. Remove the combination switch body assembly from the steering column shaft.

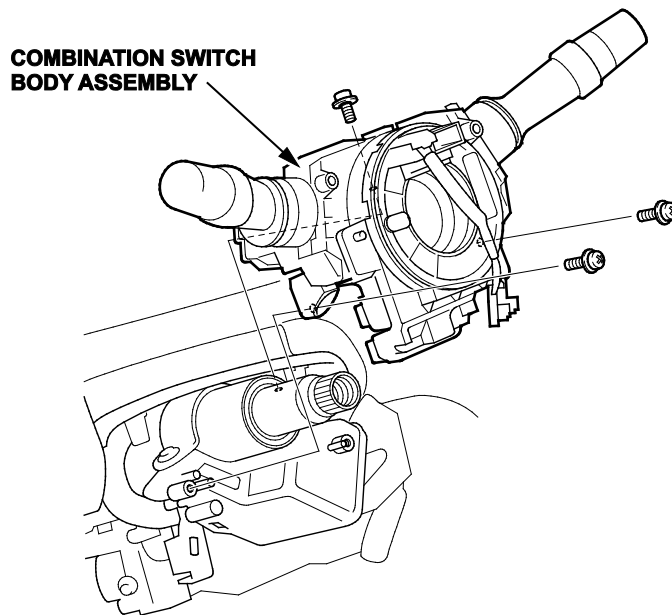

9. Disconnect the driver's knee airbag inflator connector, then remove the mounting bolts.

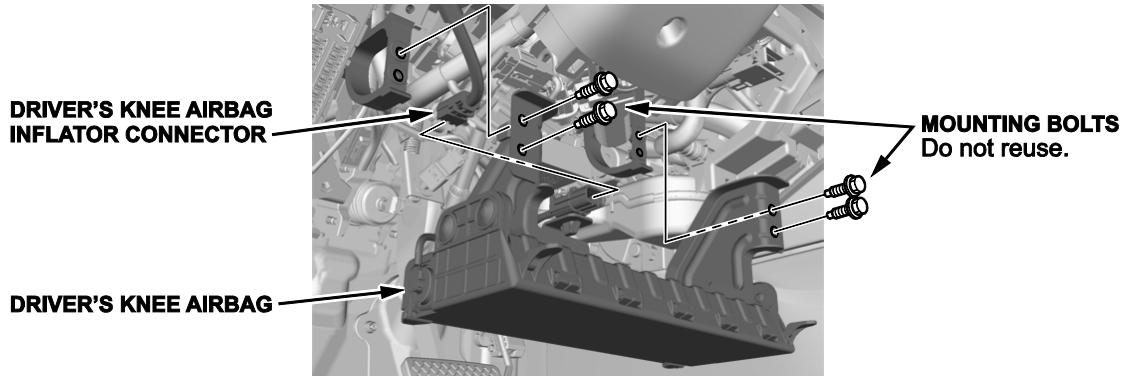

10. *MDX Only*: Remove the front door sill trim.  
11. *MDX Only*: Remove the driver's side kick panel.  
12. *MDX Only*: Remove the driver's side center console cover.  
13. Remove the steering joint cover.

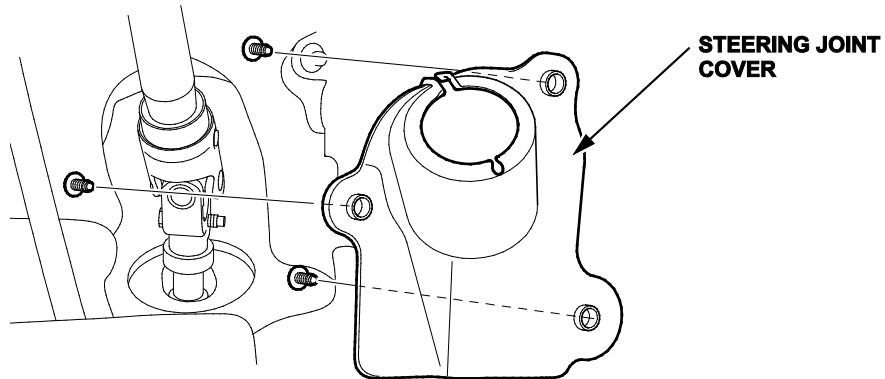

14. Hold the lower side shaft on the column with a piece of wire between the joint yoke of the lower side shaft and the joint yoke of the upper shaft to prevent the lower slide shaft from pulling out.

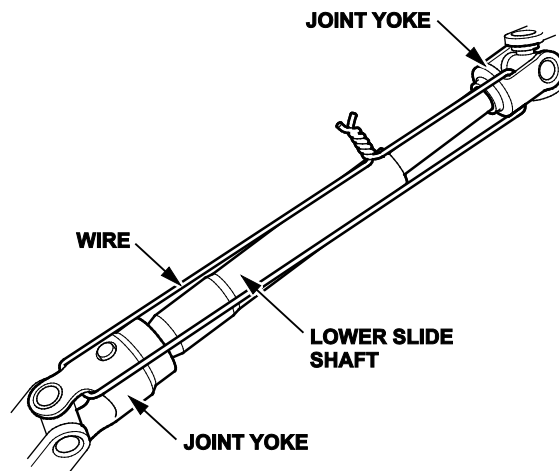

15. Remove the steering joint bolt, then disconnect the steering joint from the pinion shaft.

**NOTE:** If the center guide is in place and has not moved, leave it in place. If the center guide has come off, discard it.

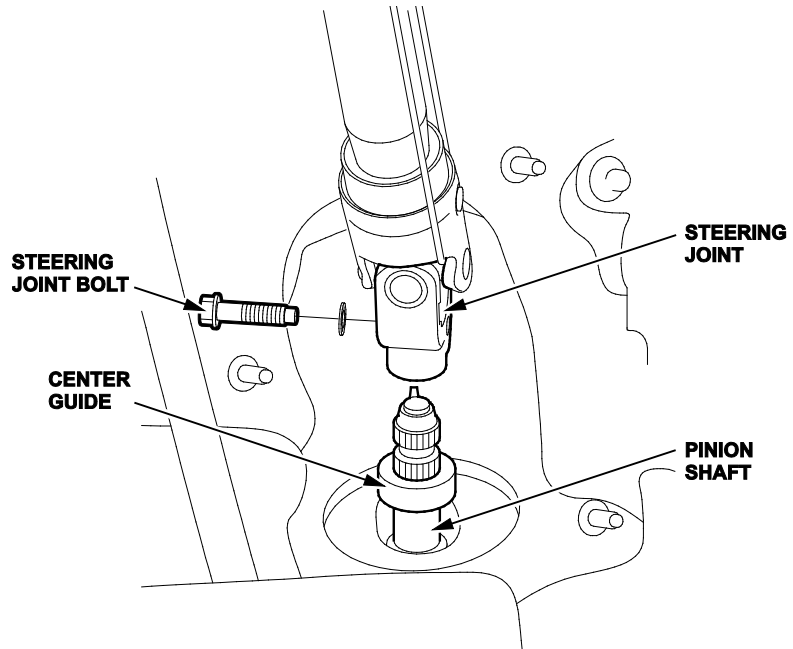

16. Remove the steering column.

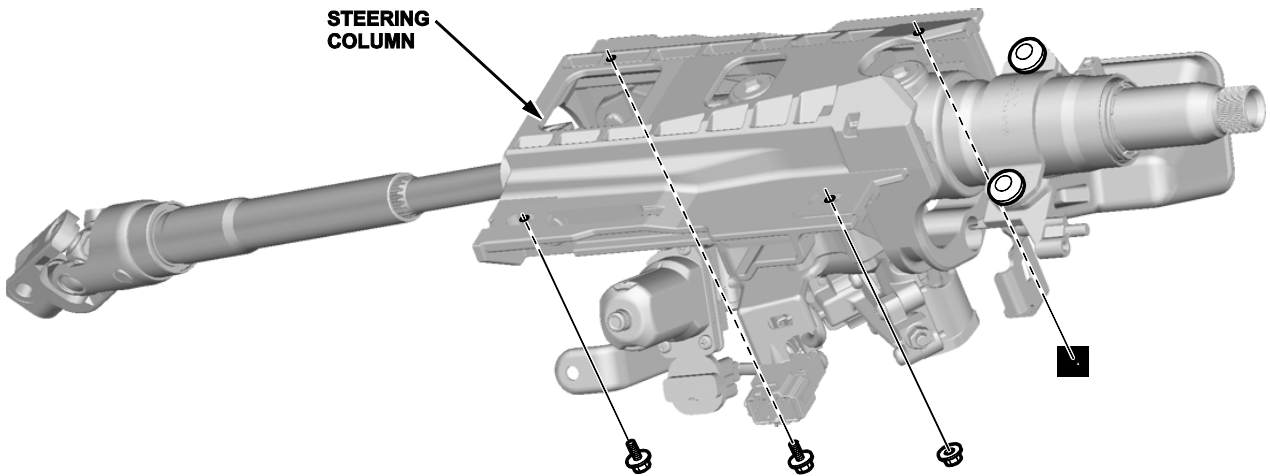

17. 2014–15 RLX, 2014 RLX Hybrid/2014–15 MDX Only: Centerpunch both of the two shear bolts and drill out the heads with a 5 mm (0.20 in) drill bit.

NOTE: The shear bolts have left-hand threads.

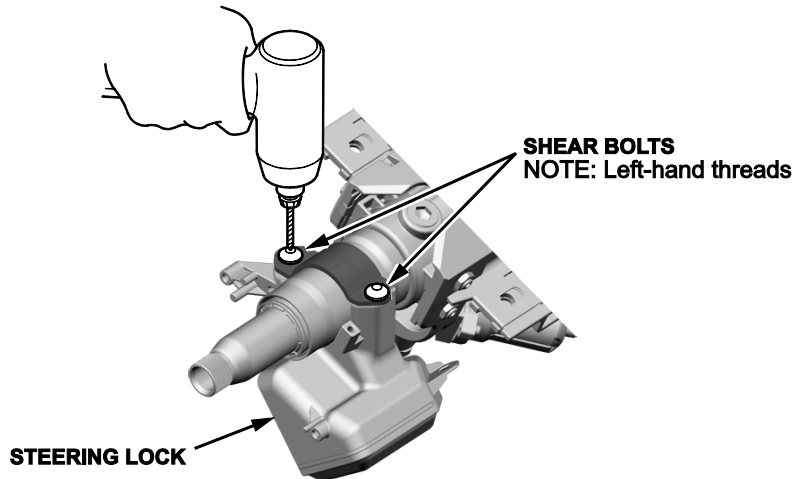

18. Install the steering lock onto the new steering column with the new bracket and new left-hand thread bolts.

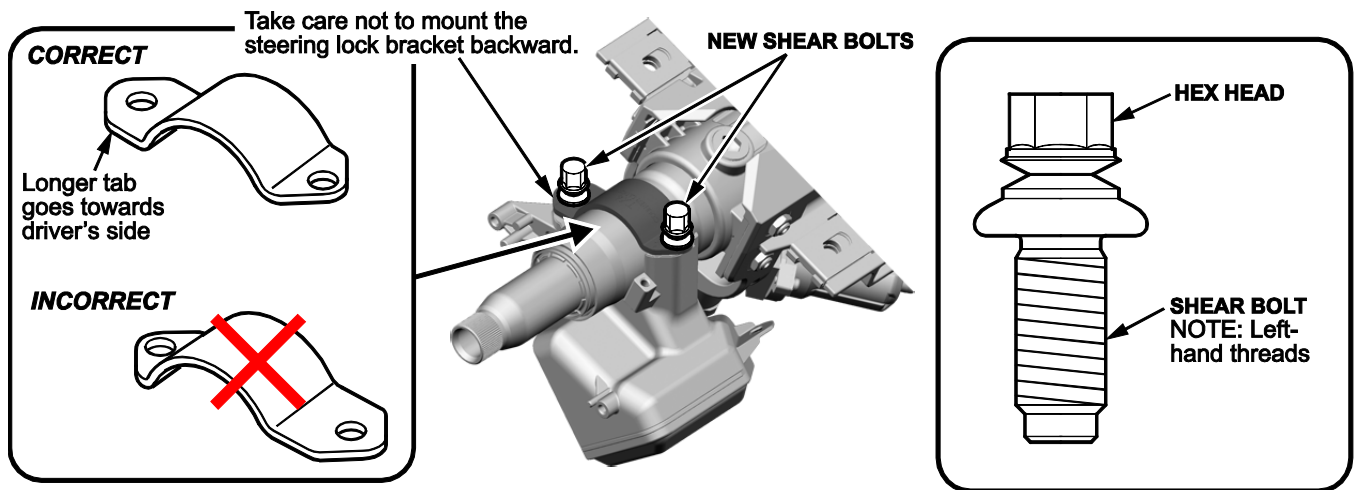

19. Install the steering column.

NOTE: Make sure the connectors are securely connected and the wires are not caught or pinched by any parts.

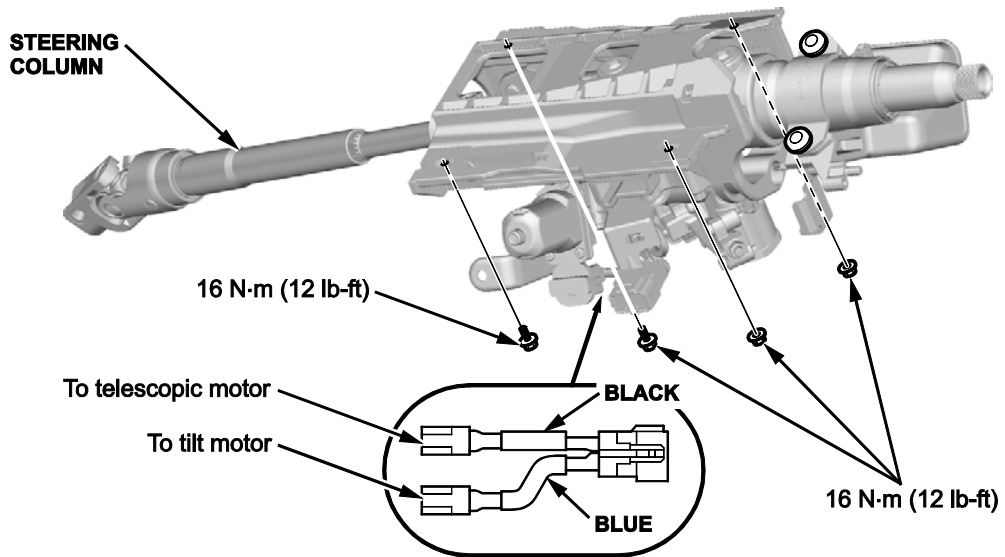

20. Remove the wire.

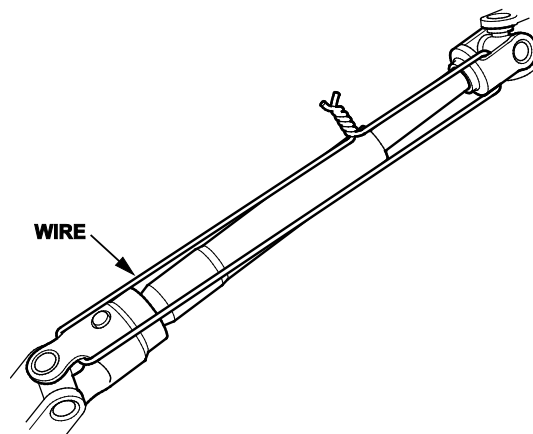

21. Set the rack in the straight-ahead position and slip the steering joint onto the pinion shaft.

NOTE: If the pinion shaft has a guide, install the steering joint by aligning the center guide. If the pinion shaft does not have a guide, position the steering column by aligning the gap within the angle.

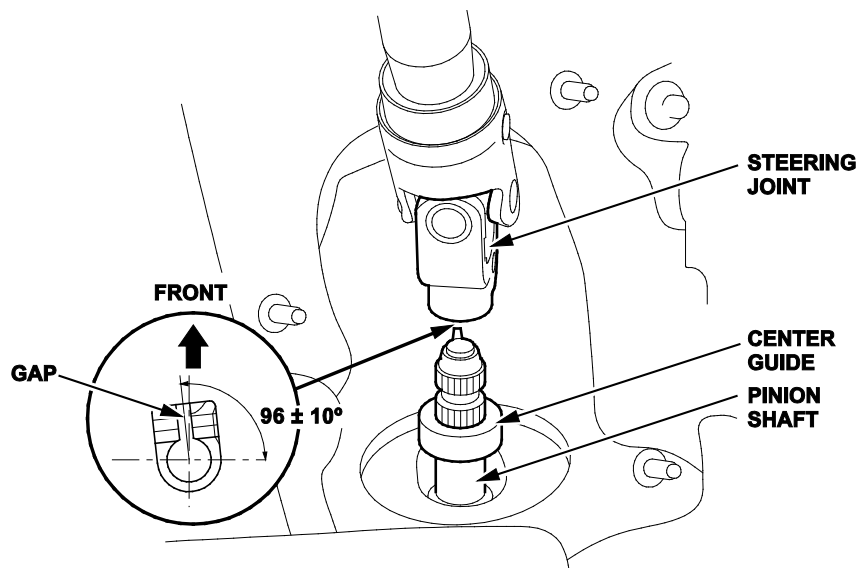

22. Align the bolt hole on the steering joint with the groove around the pinion shaft and loosely install the steering joint bolt. Be sure the joint bolt is securely in the groove. Pull on the steering joint to make sure the bolt is fully seated, then tighten it to **RLX, RLX Hybrid 29 N·m (21 lb-ft), MDX 31 N·m (23 lb-ft)**.

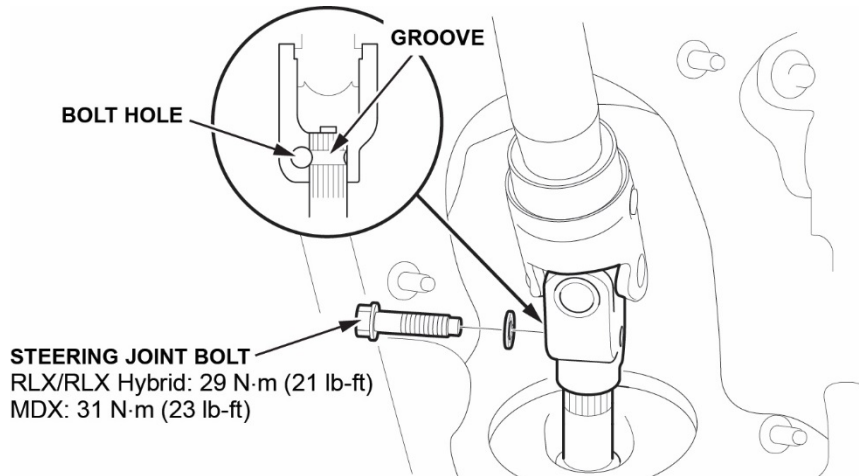

23. Install the steering joint cover.

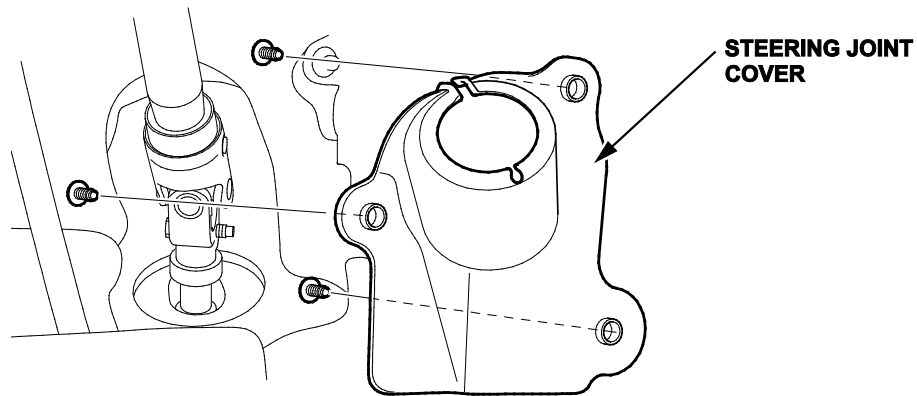

24. Install the driver's knee airbag and torque the new mounting bolts to **9.4 N·m (6.9 lb-ft)**. Then, connect the driver's knee airbag inflator connector.

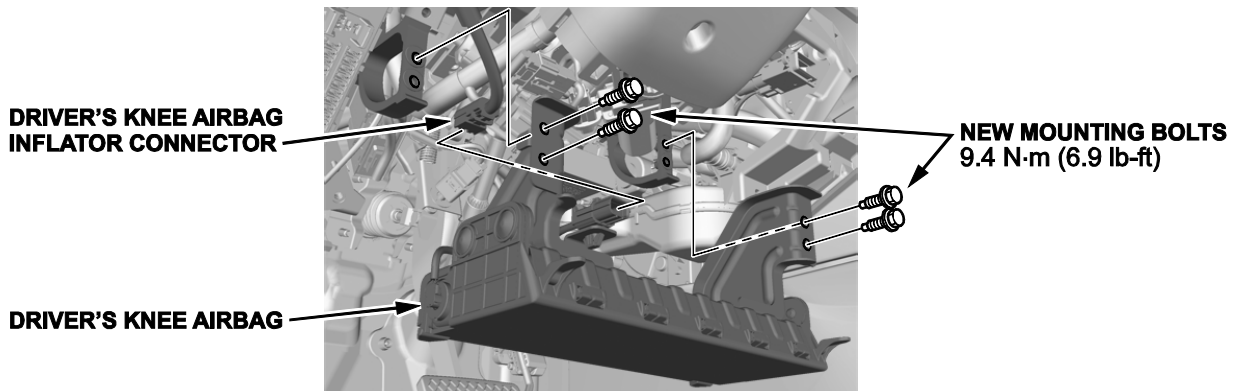



25. Install the combination switch body assembly and tighten the three screws in the numbered sequence as shown.

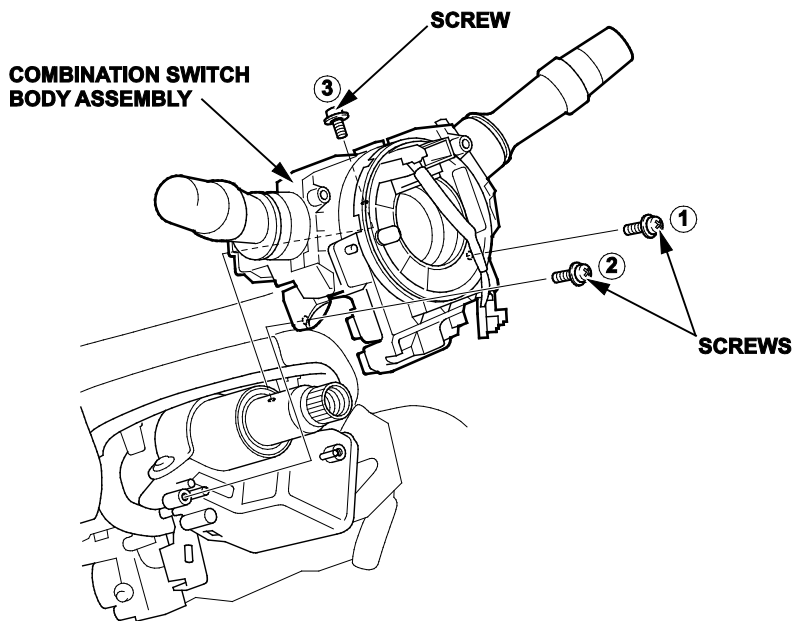

26. Install the clips and connect the following connectors:

- Tilt/telescopic motors connector
- Cable reel connector A
- Cable reel connector B
- Steering angle sensor connector
- (2014–15 models only): Electric steering lock connector

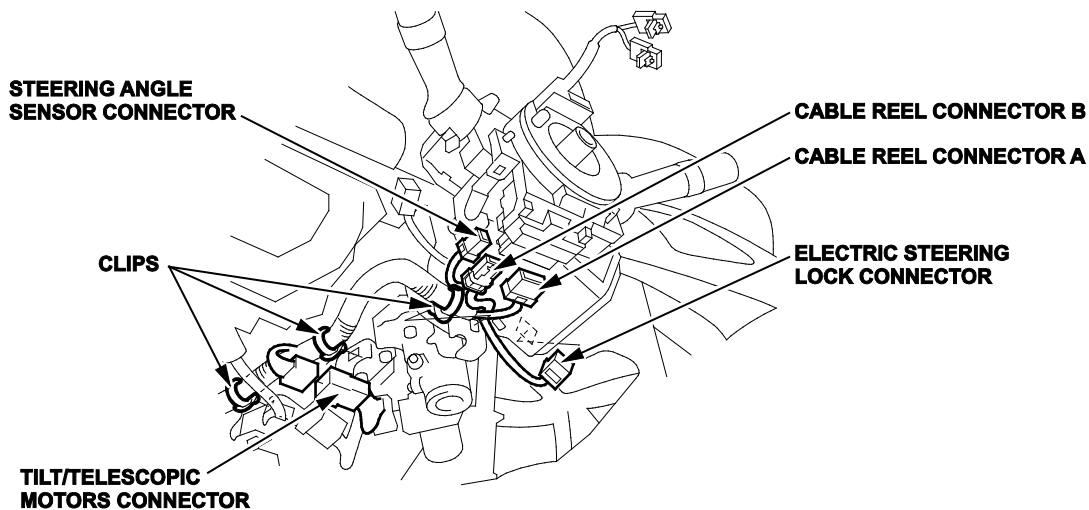

27. Install the clip and connect the combination switch connectors.

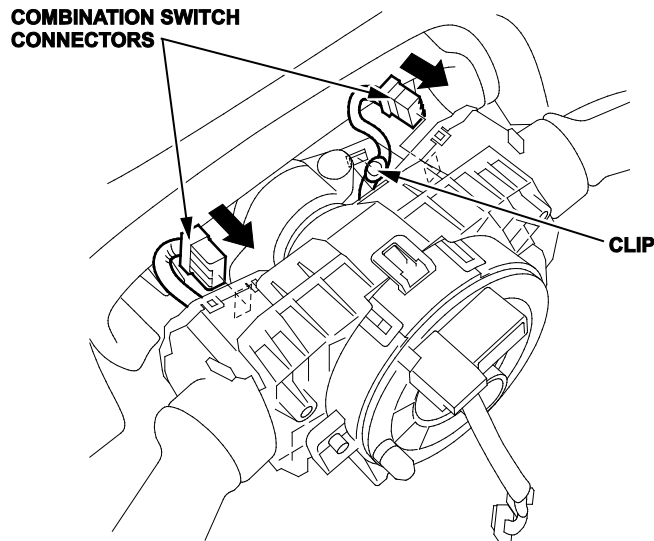

28. Install the column cover.

29. Install the driver's dashboard lower cover.

30. Install the steering wheel and tighten the new steering wheel bolt.

NOTE: The steering wheel bolt is coated with either a green or blue thread lock. The specified torque value varies depending on the type of steering wheel bolt used.

**Green-Coated Bolts: 49 N·m (36 lb-ft)**

**Blue-Coated Bolts: 60 N·m (44 lb-ft).**

31. Install the driver's airbag and torque the new Torx bolts to **9.4 N·m (6.9 lb-ft)**.

32. Do the battery terminal connection procedure.

33. Check the wheel alignment and adjust it if necessary.

34. Do the VSA sensor neutral position memorization procedure.

35. *MDX Only*: Do the steering angle sensor neutral position clear procedure.

36. *RLX, RLX Hybrid Only*: Do the steering rack end stop position learning procedure.

37. Do the driving position memory clear procedure.

NOTE: If the driving position memory is not cleared, the column will not have its full range of travel.

END