

# TECHNICAL BULLETIN

LTB00895NAS1

25 APR 2016



© Jaguar Land Rover North America, LLC

NOTE: The information in Technical Bulletins is intended for use by trained, professional Technicians with the knowledge, tools, and equipment required to do the job properly and safely. It informs these Technicians of conditions that may occur on some vehicles, or provides information that could assist in proper vehicle service. The procedures should not be performed by 'do-it-yourselfers'. If you are not a Retailer, do not assume that a condition described affects your vehicle. Contact an authorized Land Rover service facility to determine whether this bulletin applies to a specific vehicle.

## **SECTION: 309-00**

### Exhaust Valve Noise

#### **AFFECTED VEHICLE RANGE:**

##### **Range Rover Sport (LW)**

**Model Year:** 2016 Onwards  
**VIN:** 519971 Onwards  
**Assembly Plant:** Solihull

**Engine:** TDV6 3.0L Diesel - Gen 2

##### **Range Rover Sport (LW)**

**Model Year:** 2016 Onwards  
**VIN:** 617562 Onwards  
**Assembly Plant:** Solihull

**Engine:** TDV6 3.0L Diesel - Gen 2

##### **Range Rover (LG)**

**Model Year:** 2016 Onwards  
**VIN:** 216967 Onwards  
**Assembly Plant:** Solihull

**Engine:** TDV6 3.0L Diesel - Gen 2

#### **MARKETS:**

NAS

#### **CONDITION SUMMARY:**

**Situation:** A noise coming from the underneath of the vehicle may be evident. The noise is most prominent during light throttle and low speed, for example during car park maneuvers and is independent of ambient temperature range. Under these conditions, a low-level non-constant cyclical-type noise can be heard coming from the Center Exhaust system (Exhaust Valve) adjacent to the fuel tank.

**Cause:** This may be caused by a contact noise that is being emitted by the interaction of the first two gears internal to the exhaust valve located on the Center Exhaust Pipe assembly.

**Action:** In the event of a customer concern of the above, follow the Service Instruction below.

#### **PARTS:**

LR087160	Center Exhaust Pipe - Range Rover Sport (L494; EU6)	Quantity: 1
LR087156	Center Exhaust Pipe - Range Rover (L405 SWB; EU6)	Quantity: 1
WCL500030	Exhaust Clamp	Quantity: 2

#### **TOOLS:**

Cutter, Exhaust Pipe  
100-051



E130266

Refer to Workshop Manual/Service Instruction for any other required special tools.

### **WARRANTY:**

 **NOTE:** Repair procedures are under constant review, and therefore times are subject to change; those quoted here must be taken as guidance only. Always refer to TOPIx to obtain the latest repair time.

 **NOTE:** DDW requires the use of causal part numbers. Labor only claims must show the causal part number with a quantity of zero.

DESCRIPTION	SRO	TIME (HOURS)	CONDITION CODE	CAUSAL PART
Center exhaust pipe - Renew - Range Rover Sport (L494)	30.10.11	0.50	42	LR077722
Center exhaust pipe - Renew - Range Rover (L405)	30.10.11	0.50	42	LR077722

 **NOTE:** Normal Warranty procedures apply.

### **SERVICE INSTRUCTION:**

 **NOTE:** All illustrations: Range Rover Sport (L494) shown; Range Rover (L405) similar.

-  **WARNING:** Make sure to support the vehicle with axle stands.

Raise and support the vehicle (see TOPIx Workshop Manual, section 100-02: Jacking and Lifting).

-  **CAUTION:** Make sure that the exhaust system is supported with suitable retaining straps.

 **NOTE:** Rear right muffler shown; rear left muffler similar.

Locate the cutting position of the rear right muffler.

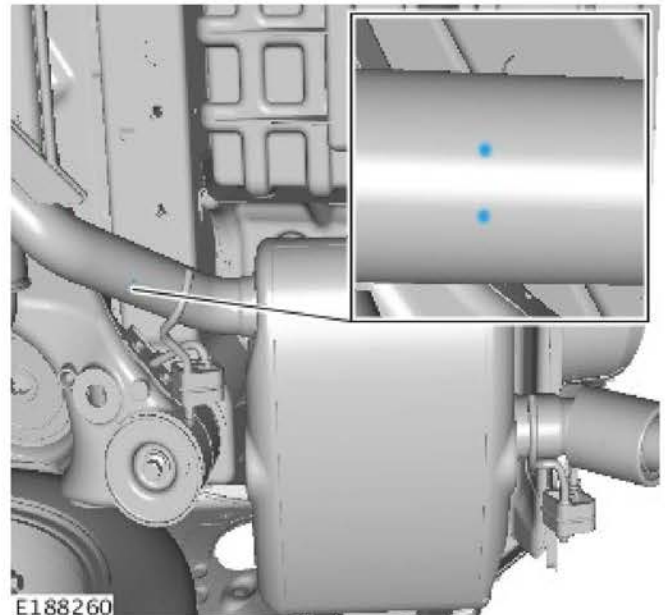

E188260

-  **CAUTION:** Make sure that the exhaust system is supported with suitable retaining straps.

 **NOTE: Rear right muffler shown; rear left muffler similar.**

Using special tool 100-051 (or similar), cut the exhaust pipe of the rear right muffler at the marked position.

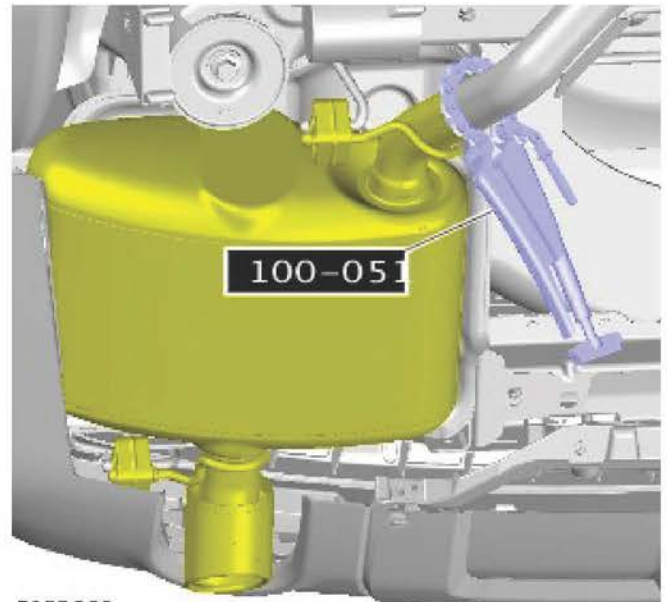

E162990

4.  **NOTE: Rear right muffler shown; rear left muffler similar.**

Repeat steps 2-4 for the rear left muffler.

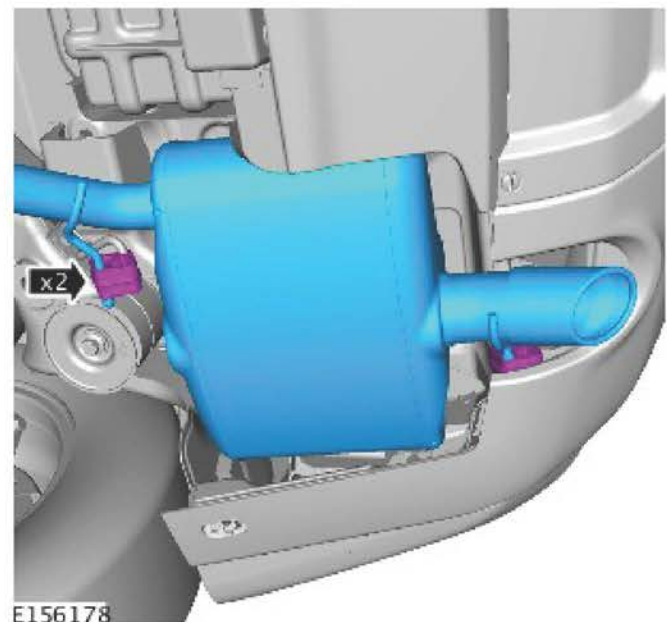

E156178

5. Disconnect the exhaust valve electrical connector and release from the bracket.

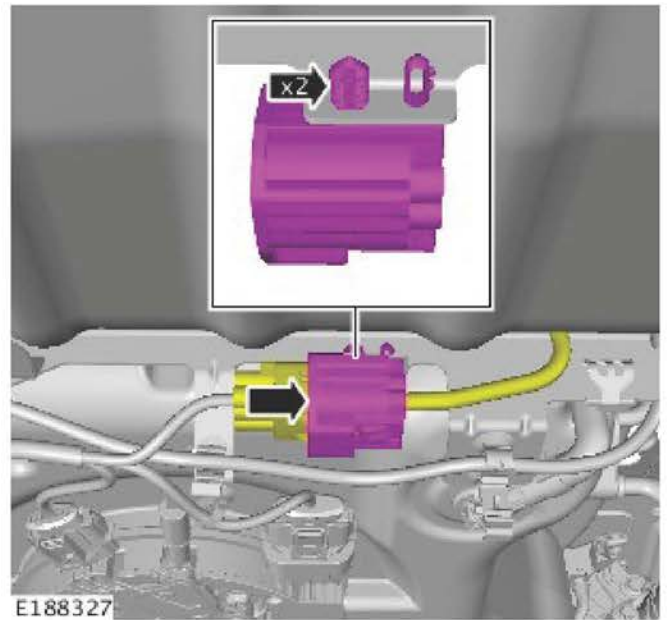

6.  **CAUTION:** Make sure that the exhaust system is supported with suitable retaining straps.

Release the center exhaust clamp.

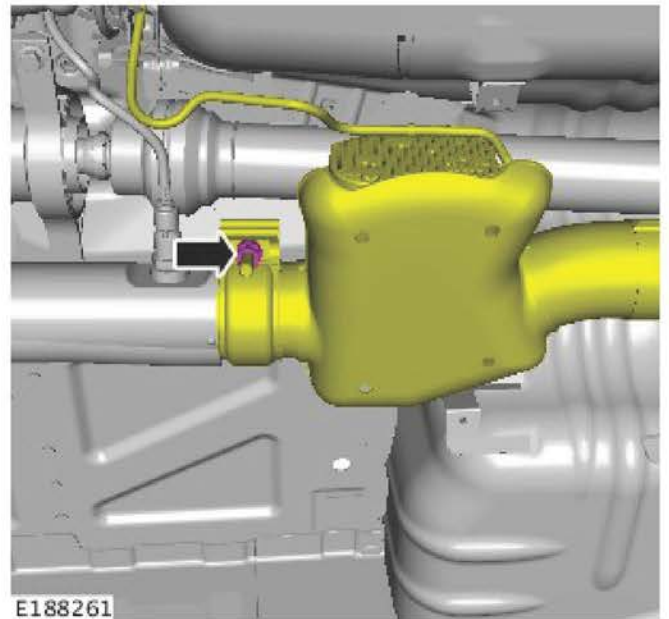

7.  **NOTE:** This step requires the aid of another technician.

Remove the center exhaust pipe.



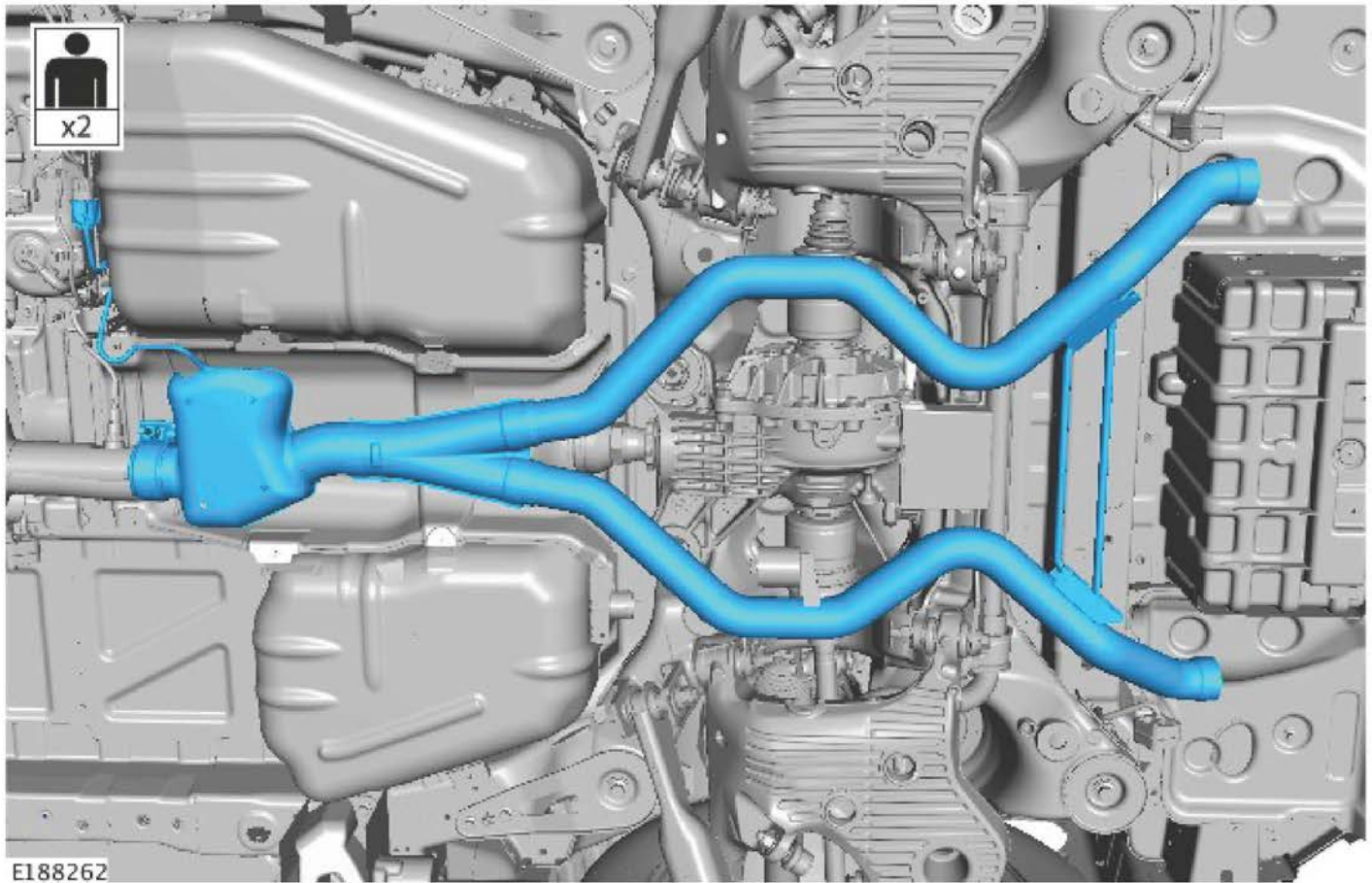

8.  **CAUTION:** Make sure that any corrosion or dirt is removed from the mating surfaces.

 **NOTE:** This step requires the aid of another technician.

Install the new clamp and center exhaust pipe.

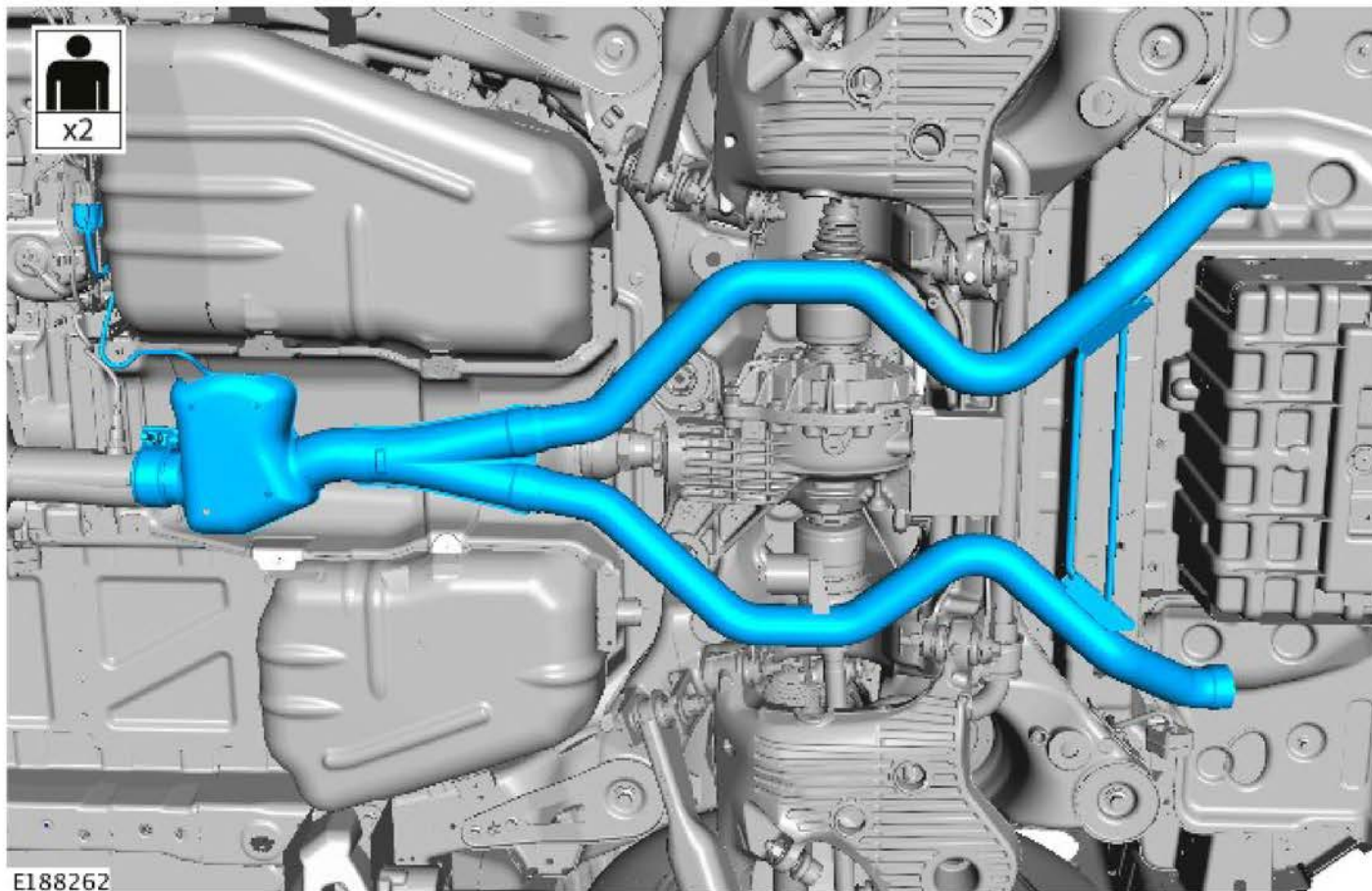

**9.** Tighten the center exhaust pipe clamp.

- Torque: 55Nm.

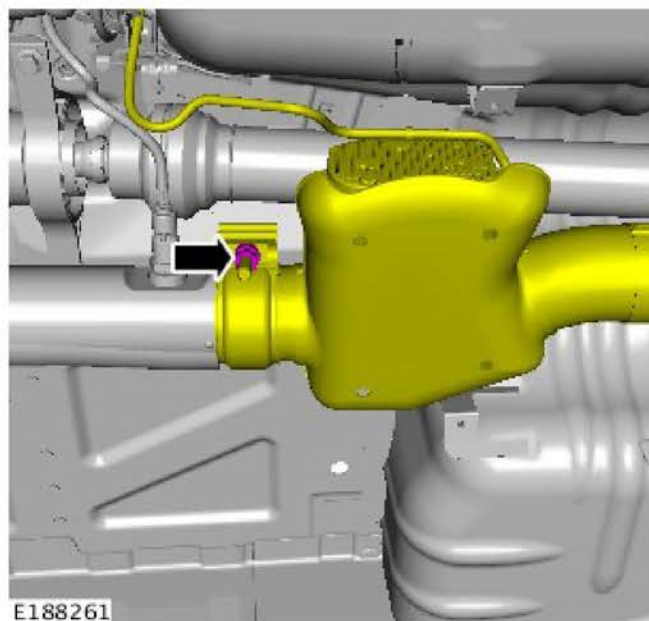

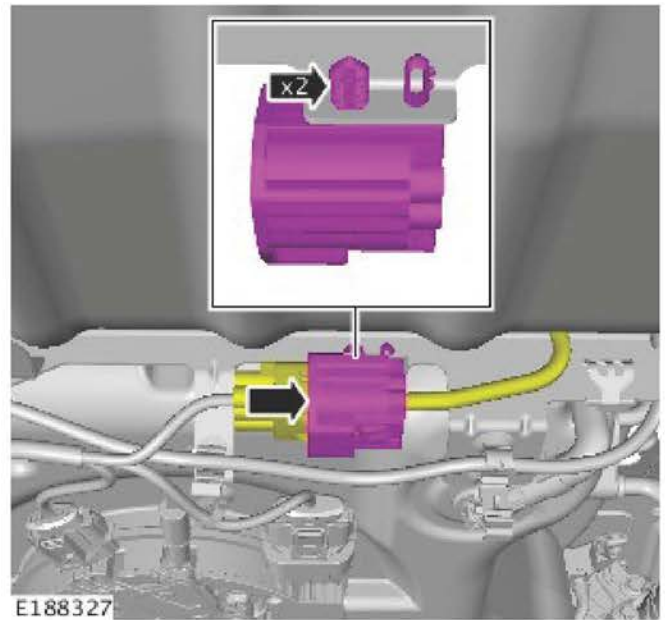

**10.** Connect the exhaust valve electrical connector and install on to the bracket.

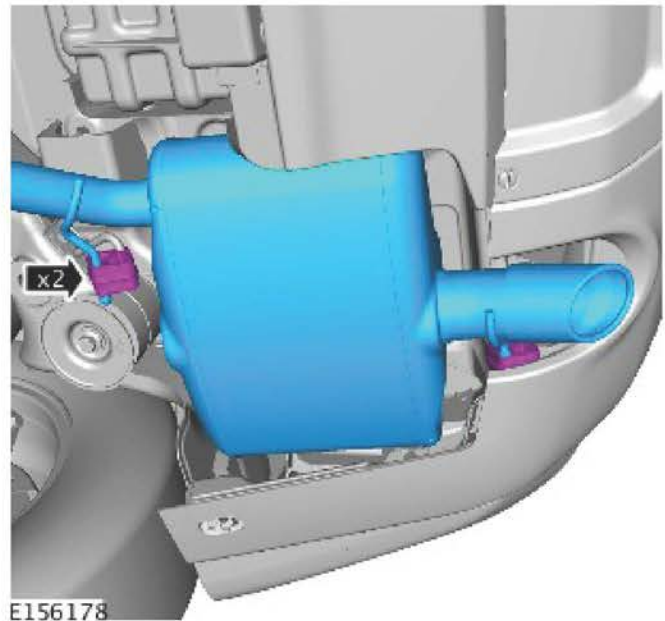

11.  **NOTE:** Rear right muffler shown; rear left muffler similar.

Install the original rear right exhaust muffler.



12.  **CAUTION:** Make sure that any corrosion or dirt is removed from the mating surfaces.

 **CAUTION:** Make sure correct alignment is maintained while carrying out the step.

 **NOTE:** Rear right muffler shown; rear left muffler similar.

Tighten the rear right muffler clamp.

- Torque: 55Nm.



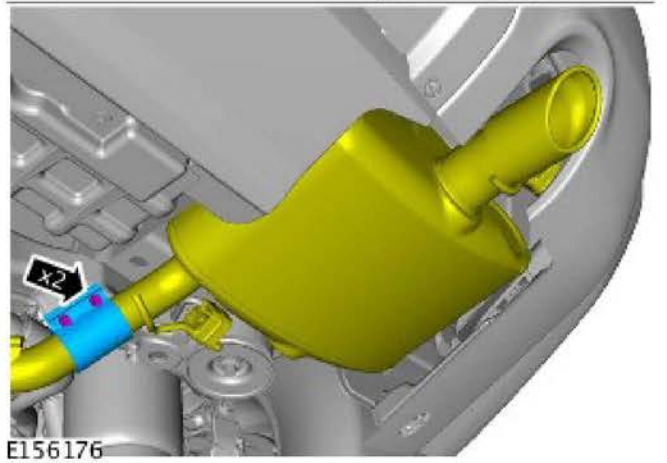
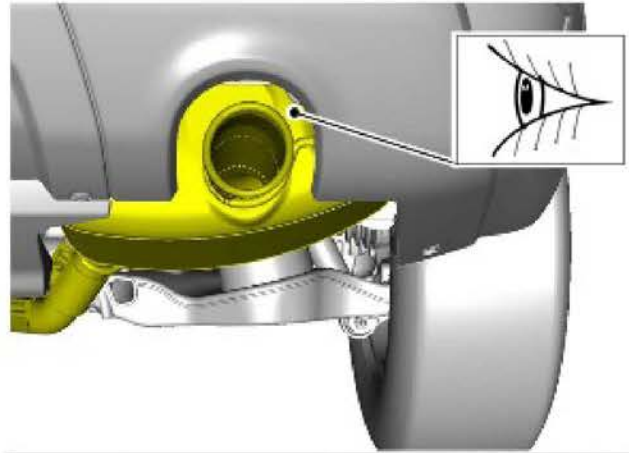

**13.** Repeat Steps 8-9 to the rear left muffler.