



DETROITTM
DEMAND PERFORMANCESM

**18SP720 – EPA10 DD15/16 Three-Filter
ESOC Fuel System to Two-Filter KM59 GEN1
Fuel System Conversion Service Kit
(P/N: A4710901455)**

KIT DESCRIPTION

This service kit includes all necessary parts to convert the DD15/16 three-filter fuel system to the DD15/16 two-filter KM59 GEN1 fuel system.

KIT CONTENTS

Part No.	Qty.	Description
A4711530575	1	Protective cover
A4710909952	1	Fuel Filter module (ESOC)
A4722030315	1	Connecting pipe
A4722003852	1	Coolant line
A4722030640	1	Radiator Support Bracket
A4730702532	1	Needle Return Line
A4730702432	1	Amplifier Return Line
A4730702332	1	Pressure Limiting Valve Return Line
A0060705401	1	Low Pressure Fuel Lines
A4730702732	1	High Pressure Pump Inlet Line
A4730702932	1	High Pressure Pump Outlet Line
A4710700635	1	Doser Fuel Supply Line
A4710780844	1	High Pressure Flange
A0000701332	1	High Pressure Fuel Line Kit
A4730700440	1	Return Line P-clip
A4700780335	2	Rail Clamps
A4700780735	1	Rear Rail Clamp
A0045405305	1	Water In Fuel Sensor Harness
A0045405205	1	Fuel Temperature Sensor Harness
A0045405105	1	Low Pressure Pump Outlet Sensor Harness
05101020	4	Zip Ties
A0009905316	1	Stud Bolt
N916016015206	2	Coolant Line Clamp
A4700780231	2	Cylinder Head Fittings
N910105010021	6	M8x55 Bolt
N910105010007	1	M8x36 Bolt
N910105008005	11	M8x25 Bolt

N910105008011	2	M8x20 Bolt
N910105008008	1	M8x16 Bolt
A0019901207	6	M6x28 Microencapsulated Bolt
N910105006023	1	M6x16 bolt
N910105006026	1	M6x12 Bolt
18SP720Rev	1	Installation Instructions

Removal of the Three-Filter Fuel System

Remove as follows:

1. Shut off the engine, apply the parking brake, chock the wheels, and perform any other applicable safety steps.



CAUTION: **ELECTRICAL SHOCK**

To avoid injury from electrical shock, use care when connecting battery cables. The magnetic switch studs are at battery voltage.

2. Disconnect the batteries.
3. Steam clean the engine.



WARNING: **FIRE HAZARD**

Do not power wash or steam clean the engine bay in the area of vehicle electrical components, unless specified by vehicle manuals or service literature. Power washing/steam cleaning can permanently damage these components, which could result in fire, personal injury, or property damage.

4. Remove the fuel feed line from the fuel filter module.
5. Using W470589039100, install J-48710 fuel pressure test kit onto the fuel feed line at the fuel filter module.
6. Remove the fuel tank fill caps.
7. Using regulator, adjust the system pressure to 345 kPa (50 psi).
8. Pressurize the fuel system for two minutes.
9. Remove J-48710 fuel pressure test kit from the fuel filter module.
10. Install the fuel tank fill caps.
11. Remove the chassis return line from the fuel filter module.
12. Remove the coolant reservoir cap.
13. Open the coolant drain plug (1) located on the left side of the engine block and attach a hose to the plug.

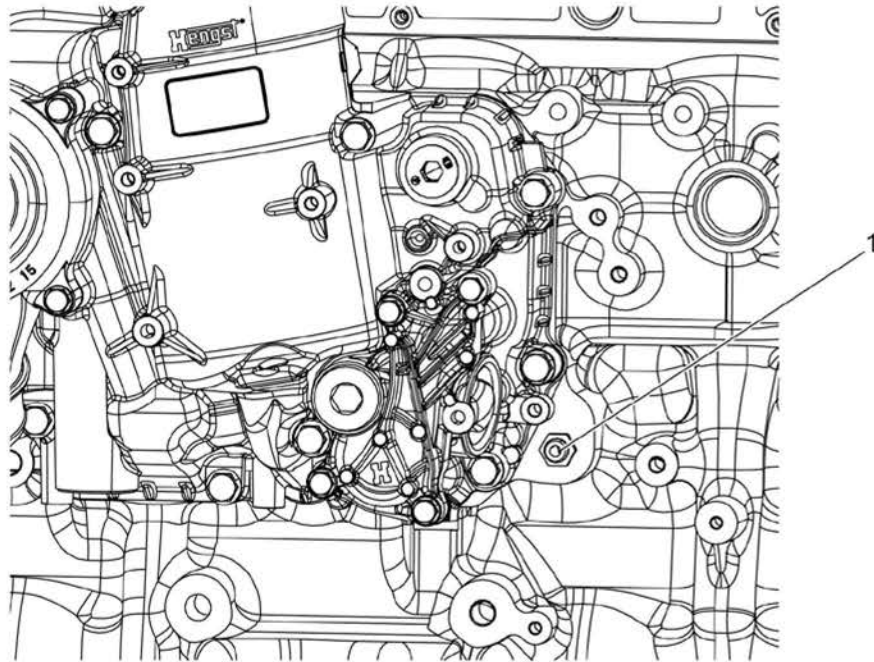

d090094

NOTICE:

Coolant is a hazardous material and needs to be disposed in an environmentally responsible manner.

14. Collect the used coolant in a suitable container and if necessary, dispose of the solution in an environmentally responsible manner according to state and federal Environmental Protection Agency (EPA) recommendations.

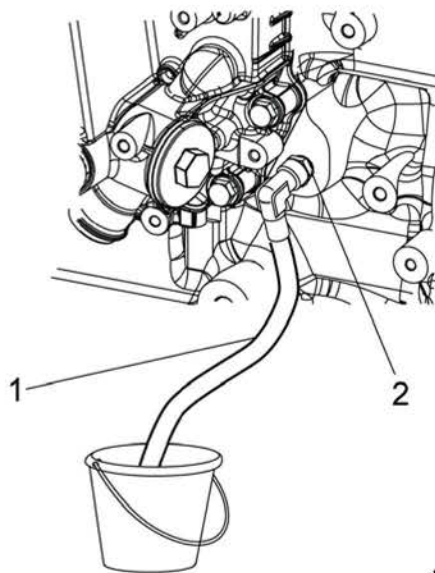

d200025

15. Close the drain plug. Torque to 30 N•m (22 lb•ft).
16. Disconnect the coolant lines from the front and bottom of the fuel filter module.
17. Remove the P-clip bolt holding the coolant line to the oil/coolant module.
18. Disconnect the coolant line from the oil/coolant module and remove the coolant line from the engine. Discard coolant line.
19. Disconnect the water-in-fuel, fuel temperature and low pressure sensor electrical connectors.
20. If equipped, remove and discard the emergency lubrication line from the fuel filter module and the high pressure flange.
21. Remove the high pressure pump inlet line from the fuel filter module and the high pressure flange. Discard the high pressure pump inlet line.
22. Remove the high pressure pump outlet line from the fuel filter module and the high pressure flange. Discard the high pressure pump outlet line.
23. On V5 three filter fuel systems only, remove the banjo bolt from the low pressure fuel pump inlet line and both sealing washers.
24. On V5 three filter fuel system only, remove and discard the P-clip bolt securing the amplifier line to the fuel filter module.
25. Remove the low pressure fuel pump inlet line from the fuel filter module and the low pressure flange. Discard the low pressure fuel pump inlet line.
26. Remove the low pressure fuel pump outlet line from the fuel filter module and the low pressure flange. Discard the low pressure fuel pump outlet line.
27. Remove the needle, amplifier, and pressure limiting valve return lines and needle return pressure control valve from the fuel filter module.
28. Disconnect the engine wiring harness clip from the fuel filter module.
29. Remove the four bolts securing the fuel filter module to the cylinder block. Discard the four bolts.
30. Remove fuel filter module from the engine. Discard the fuel filter module.
31. Remove the fuel cooler rubber coupling from the engine block. Discard the fuel cooler rubber coupling.
32. Remove the radiator support rod from the radiator support bracket. Position aside radiator support rod.
33. Remove the radiator support bracket. Discard the radiator support bracket.
34. Disconnect the coolant line from the air compressor and remove the coolant line from the engine. Discard the coolant line.
35. Remove and discard the low pressure flange and gasket from the high pressure fuel pump.
36. Remove the doser fuel supply line from the doser block. Discard the doser fuel supply line.
37. Remove the needle return line from the high pressure flange.
38. Unclip the engine wiring harness from the high pressure flange.
39. Remove and discard the high pressure flange and gasket from the high pressure fuel pump.
40. Remove and discard the return lines P-clip bolt from the mounting bracket (1).
 - a. The graphic below illustrates the DD15/16 engines with a serial number before 472901S0012796.

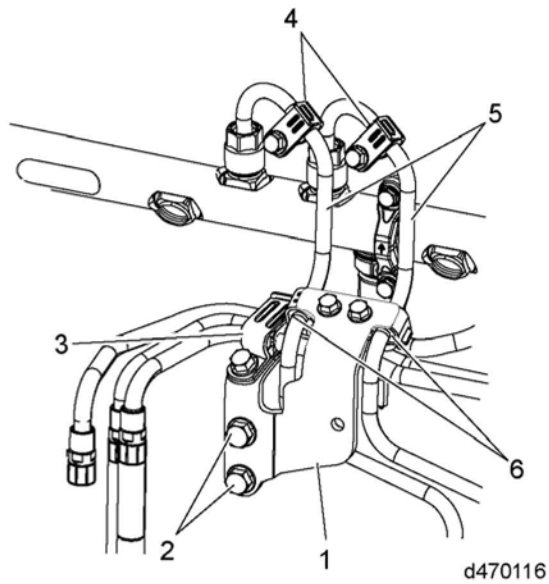

- b. The graphic below illustrates the DD15/16 engines with a serial number after 472901S0012796 and all DD13 engines.

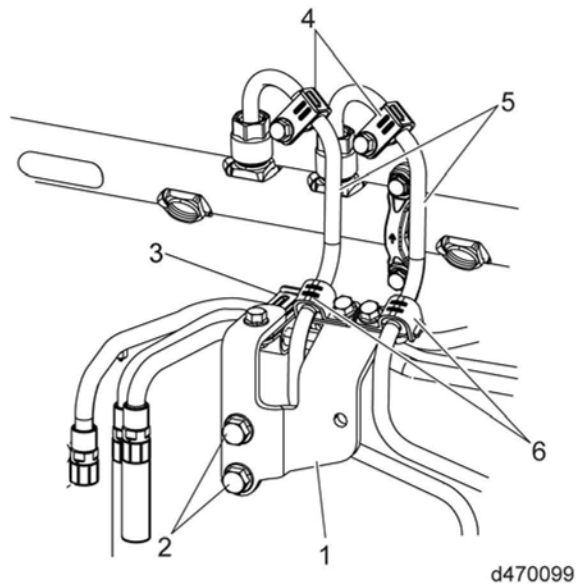

41. Remove and discard the two bolts and P-clips (6) from the mounting bracket (1).
42. Cover the high pressure fuel pump elements and high pressure fuel rail feed line sealing areas on the fuel rail with a clean shop towel.
43. Remove and discard the mounting bracket bolts (2) from the intake manifold and the mounting bracket (1).

NOTE:

When using tool J-48770 to remove the high pressure pump rail feed lines, hold the high pressure pump fitting with a 24mm wrench.

44. Using tool J-48770, remove the high pressure pump rail feed lines (5) and vibration dampers (4) from the fuel rail and high pressure fuel pump. Discard the high pressure pump rail feed lines and vibration dampers.
45. Remove and discard the return lines P-clip (3).
46. Holding the rear needle cylinder head fitting with J-48836, use J-48770 to remove the needle return line from the rear cylinder head fitting. Discard the needle return line.
47. Holding the rear amplifier cylinder head fitting with J-48836, use J-48770 to remove the amplifier return line from the rear amplifier cylinder head fitting. Discard the amplifier return line.
48. Remove and discard the needle and amplifier cylinder head fittings and sealing washers from the cylinder head.
49. Remove and discard the Pressure Limiting Valve (PLV) line from the fuel rail.
50. Remove and discard all six rail clamp bolts and three rail clamps from the engine.

Installation of the Two-Filter Fuel System

Install as follows:

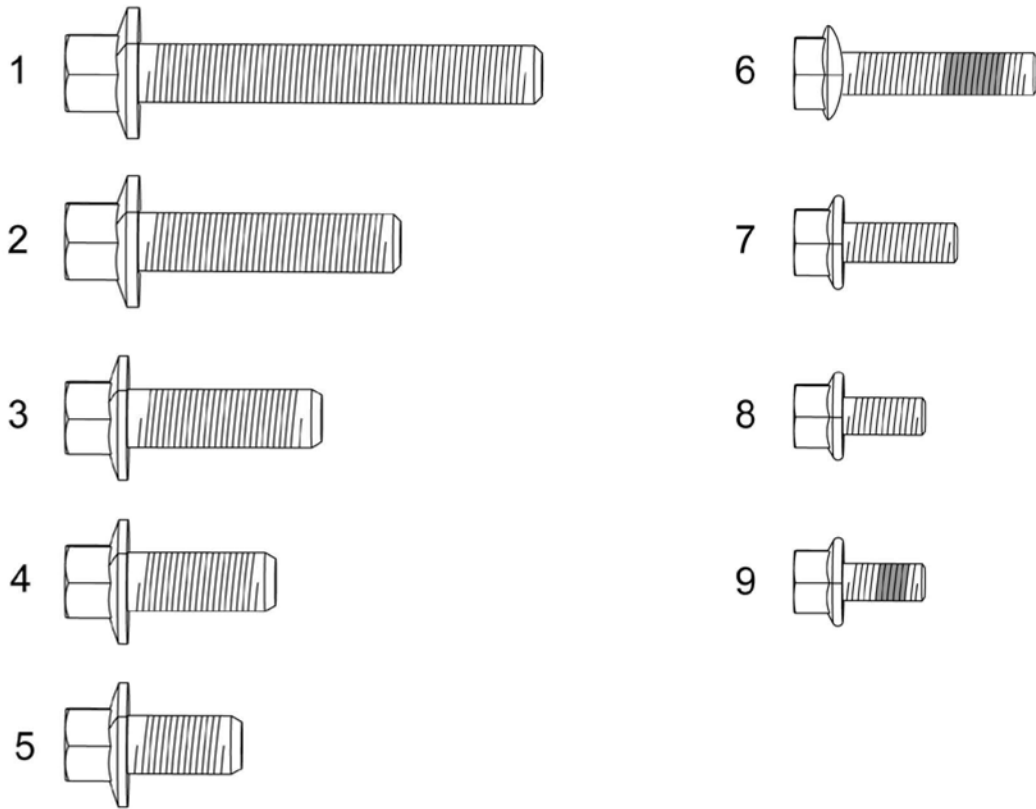

d470249

Bolt Number	Part Number	Size	Quantity
1	N910105010021	M8x55	6
2	N910105010007	M8x36	1
3	N910105008005	M8x25	11
4	N910105008011	M8x20	2
5	N910105008008	M8x16	1
6	A4720940155	M6x28 (micro-encapsulated)	6
7	N910105006023	M6x16	1
8	N910105006026	M6x12	1
9	N000000007957	M6x12 (micro-encapsulated)	4

1. Remove the water drain bolt (1) for the new fuel filter module.

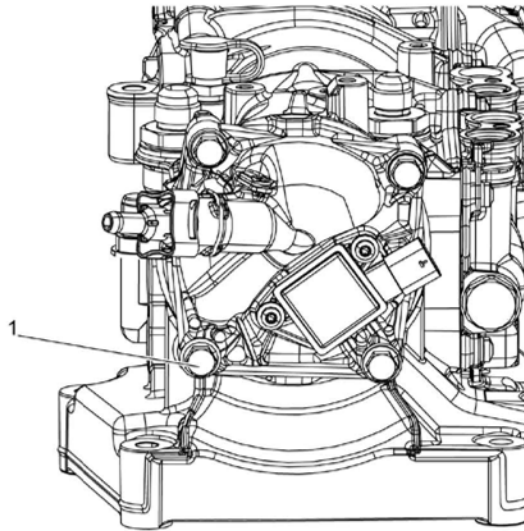

d470277a

2. Install the new stud bolt (1) on to the fuel filter module. Torque to 20-22 N·m (15-16 lb·ft).

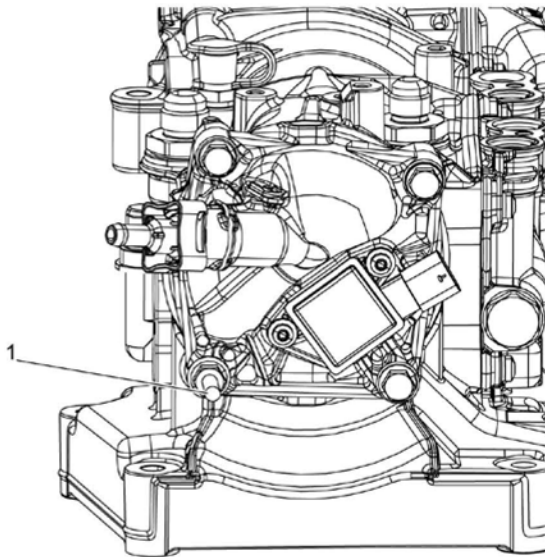

d470277

3. Using (bolt number 8), install the new low pressure sensor protective cover on to the fuel filter module. Torque to 10 N·m (7 lb·ft).
4. Connect the new low pressure pump outlet (LPPO) sensor harness on to the LPPO sensor.
5. Clip the LPPO sensor harness (1) on to the protective cover.

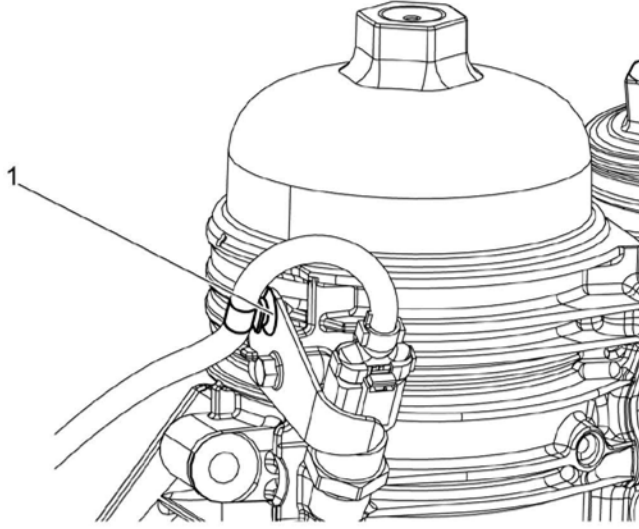

d470282

6. Install the LPPO sensor harness (1) on to the stud bolt.

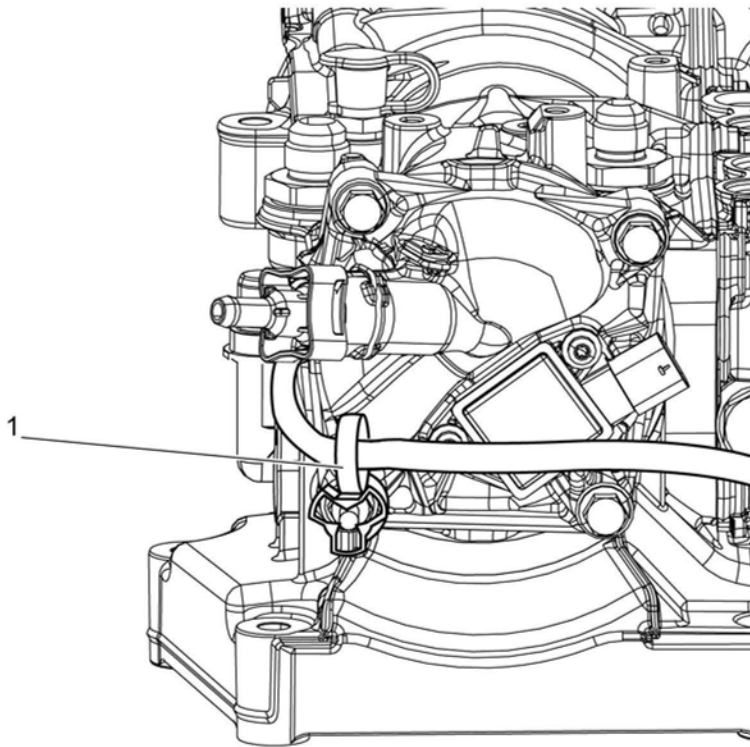

d470278a

NOTE:

The rear fuel rail clamp has mounting holes for the high pressure fuel lines mounting bracket.

7. With the arrows pointing upwards, install the three new fuel rail clamps and six new fuel rail clamp bolts (M6x28 microencapsulated bolt number 6). Torque to 14 N·m (120 lb·in.).
8. Install the new PLV return line, new sealing washers and new PLV banjo bolt. Hand-tighten the PLV banjo bolt. Do not torque at this time.
9. Using new sealing washers, install the new needle and amplifier cylinder head fittings on to the cylinder head. Torque to 55-60 N·m (40-44 lb·ft).
10. Install the new needle and amplifier return lines on to the cylinder head fittings. Hand tighten the lines. Do not torque at this time.

NOTICE:

DO NOT install any high pressure fuel line bolts and fittings using power tools. All bolts and fittings MUST be installed using hand tools.



**WARNING:
PERSONAL INJURY**

All parts provided within this kit must be installed in the proper locations, and MUST be fastened to the specified torque. Failure to properly torque hardware/components will result in failure of a high pressure fuel feed line, resulting in possible fire and/or personal injury.

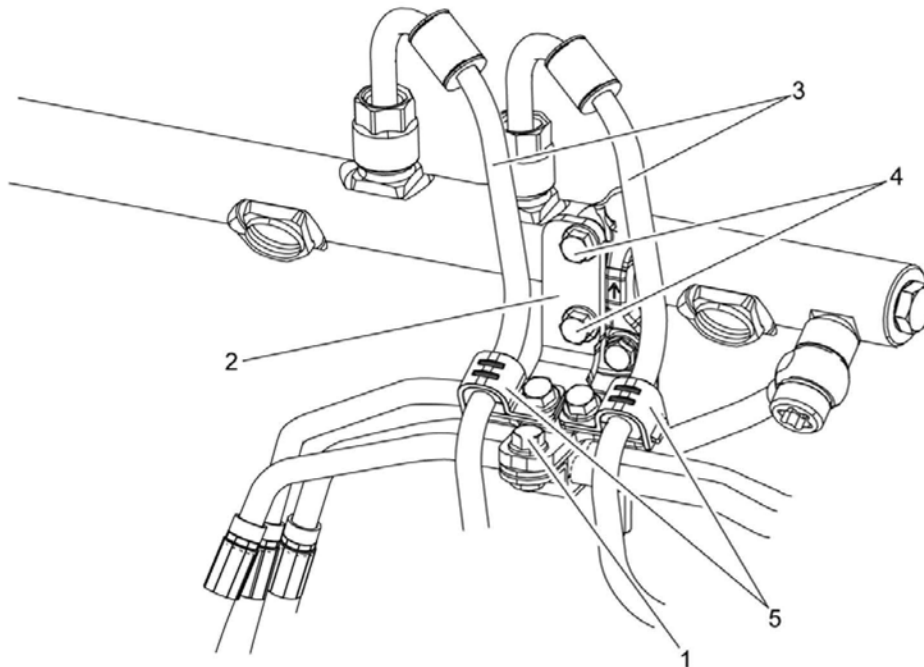

d470160c

11. Install the new return lines P-clip on to the return lines.

12. Remove the shop towels covering the high pressure fuel pump elements and high pressure fuel rail feed line sealing areas on the fuel rail.
13. Clean the sealing area inside the high pressure fuel pump fittings using a clean, lint-free cloth.



14. Clean the sealing area inside the high pressure fuel rail using a clean, lint-free cloth.



15. Install the rear high pressure fuel line (3) to the fuel rail and the high pressure fuel pump. Hand tighten the nuts.
16. Using tool J-48770, torque the rear high pressure fuel line nuts to 40 N·m (30 lb·ft).
17. Install the front high pressure fuel line (3) to the fuel rail and the high pressure fuel pump. Hand tighten the nuts.
18. Using tool J-48770, torque the front high pressure fuel line nuts to 40 N·m (30 lb·ft).
19. Install the new mounting bracket (2) and two new mounting bracket bolts (4) (M6x12 microencapsulated bolt number 9) to the fuel rail clamp. Torque to 14 N·m (124 lb·in.).
20. Install the two new P-clips (5) and two new bolts (M6x12 microencapsulated bolt number 9) to the high pressure fuel rail feed lines (3) and the mounting bracket (2). Torque to 14 N·m (124 lb·in.).
21. Install a new bolt (1) (M6x16 bolt number 7) on to the return lines P-clip. Torque to 14 N·m (124 lb·in.).

NOTE:

DO NOT use high pressure fuel lines without new vibration dampers and new bolts installed.

22. Using J-48770, torque the needle and amplifier return lines on to the cylinder head fittings at the rear of the cylinder head to 25 N·m (18 lb·ft).
23. Torque the PLV line to the fuel rail to 30-33 N·m (22-24 lb·ft).
24. Clean the high pressure flange mating surface on the high pressure fuel pump.
25. Install the new high pressure fuel flange onto the high pressure fuel pump using M8x25 bolt number 3. Torque to 30 N·m (22 lb·ft).
26. Clip the engine wiring harness on to the high pressure flange.
27. Install the new doser fuel supply line with new sealing washers on to the high pressure fuel flange and doser block. Torque to 25 N·m (18 lb·ft).
28. Lightly lubricate the new fuel cooler rubber coupling with clean engine coolant and install the new rubber coupling into the cylinder block.
29. Install the new radiator support bracket on to the engine using M8x55 bolt number 1 and M8x36 bolt number 2. Torque to 60 N·m (44 lb·ft).
30. Position back radiator support rod and install the radiator support rod on to the radiator support bracket. Torque to OEM specification.

NOTE: The new radiator support bracket no longer has a mounting point for the fuel filter module; this will not affect the stability of the fuel filter module.

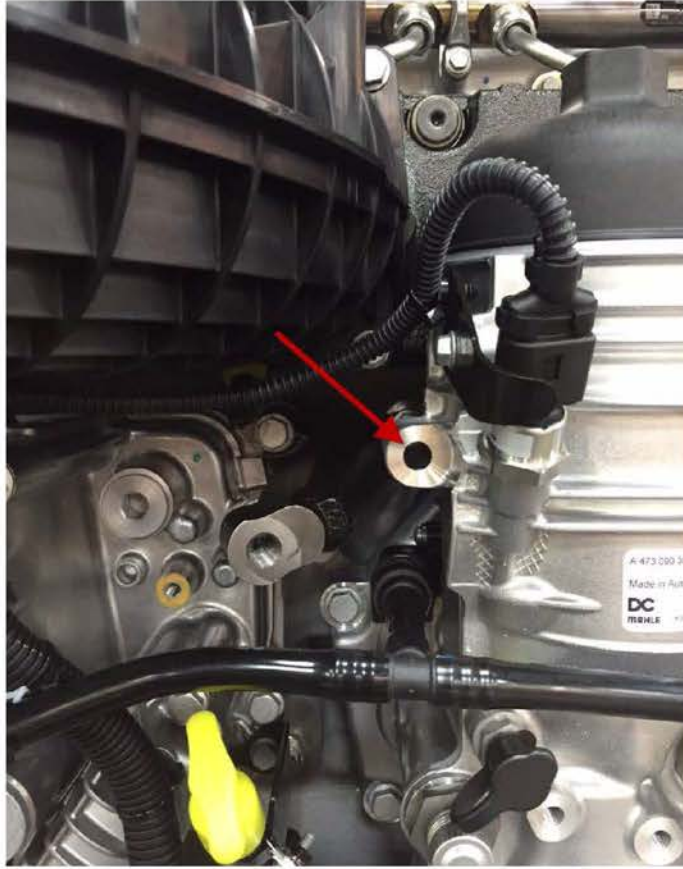

31. Install the new fuel filter module to the cylinder block with the four new mounting bolts (M8x55 bolt number 1). Torque to 60 N·m (44 lb·ft).
32. Install and connect the new coolant line on to the air compressor, fuel filter and oil/coolant filter module.
33. Install the new P-clips on to the coolant line.

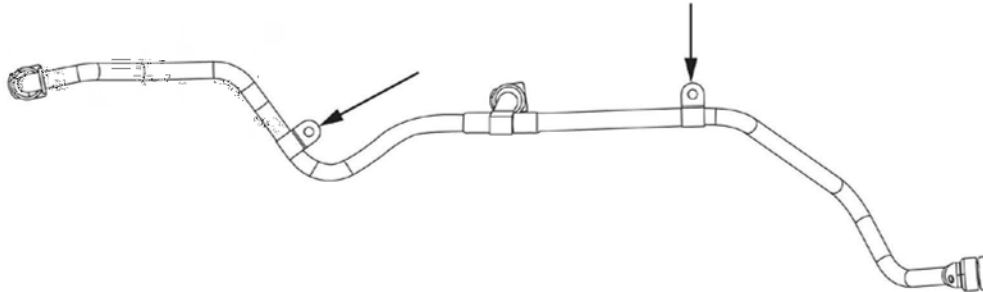

d130044

34. Install the mounting bolts (M8x20 bolt number 4) securing coolant line clips to the fuel filter module and oil/coolant filter module. Torque to 30 N·m (22 lb·ft).
35. Using a zip tie (1), attach the LPPO sensor harness H-clip on to the coolant line.

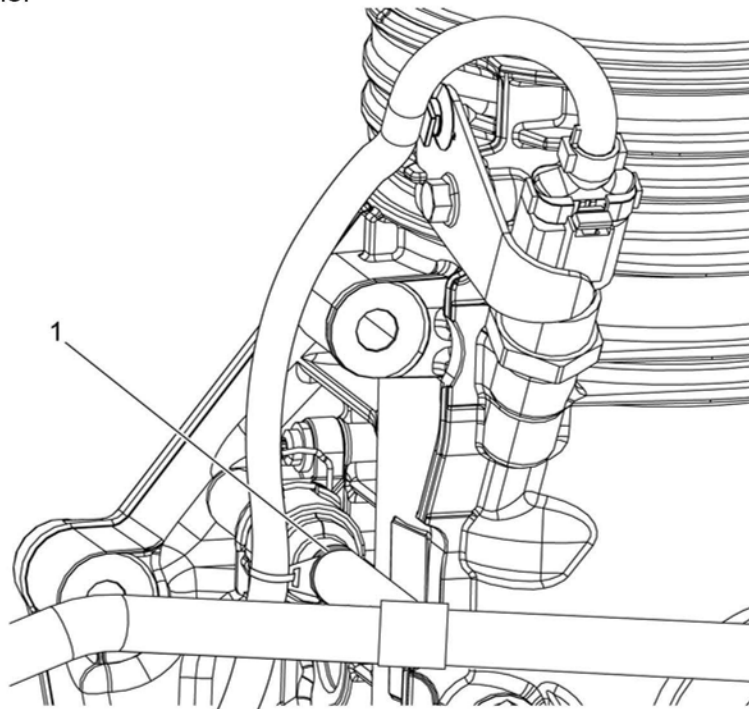

d470279

36. Using new sealing washers, install the needle, amplifier, and pressure limiting valve return lines on to the fuel filter module. Torque to 30-33 N·m (22-24 lb·ft).

37. Lubricate the new high pressure pump inlet/outlet lines and the low pressure fuel pump inlet/outlet lines O-rings with a light coat of clean diesel fuel.
38. Install the new low pressure fuel pump inlet and outlet lines on to the fuel filter module and the high pressure fuel pump using M8x25 bolt number 3. Torque to 30 N·m (22 lb·ft).
39. Install the new wiring harness bracket on to the fuel filter module using M8x25 bolt number 3 and low pressure lines using M8x16 bolt number 5. Torque to 30 N·m (22 lb·ft).
40. Install the new high pressure pump inlet and outlet lines on to the fuel filter module and the high pressure flange using M8x25 bolt number 3. Torque to 30 N·m (22 lb·ft).

NOTICE:

Wiring harnesses can NOT come into contact with ANY coolant lines or fuel lines.

41. Install and connect the new water-in-fuel and fuel temperature wiring harnesses.
42. Connect the new LPPO wiring harness.
43. Using a zip tie (1), attach the water-in-fuel wiring harness to the wiring harness bracket.

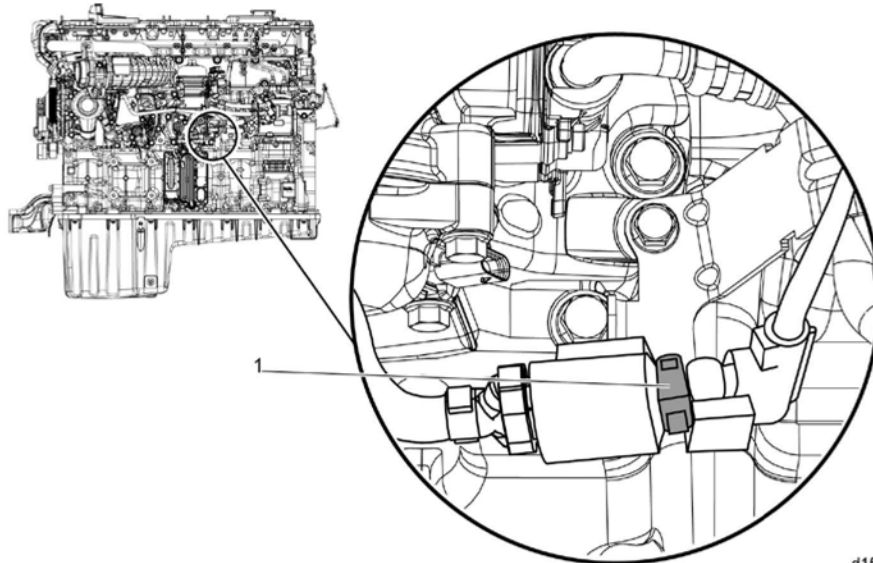

d150255

44. Using the zip tie (1), attach the fuel temperature and the LPPO wiring harnesses to the low pressure flange.

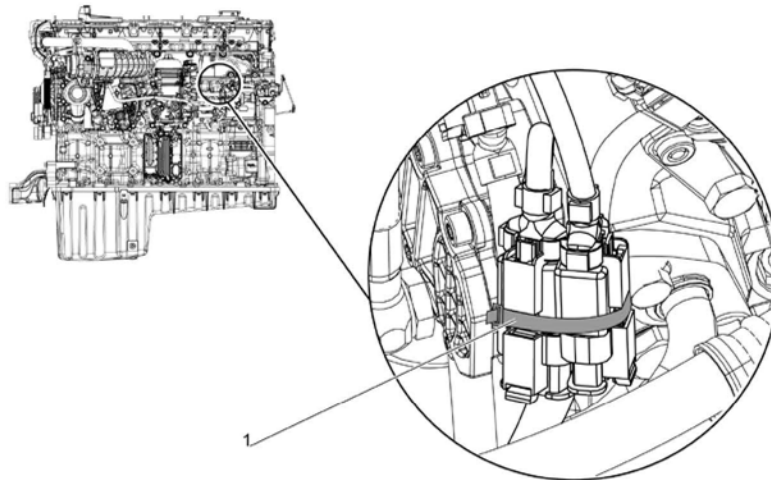

d150257

45. Using a zip tie (1), attach the LPPO wiring harness H-clip to the coolant line.

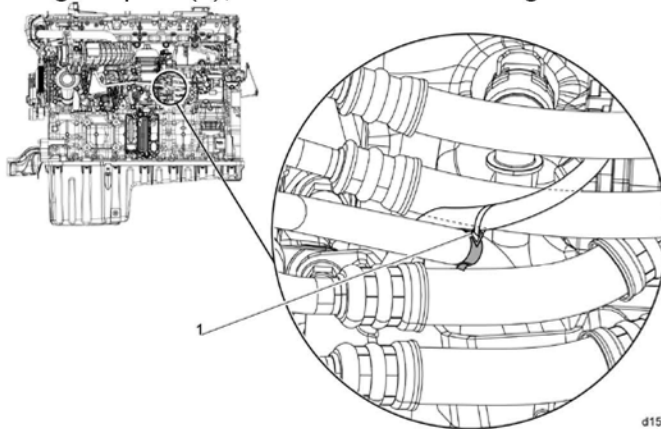

d150256

46. Install the chassis fuel feed and return lines on to the fuel filter module. Refer to OEM procedures.



**CAUTION:
ELECTRICAL SHOCK**

To avoid injury from electrical shock, use care when connecting battery cables. The magnetic switch studs are at battery voltage.

47. Connect the batteries.
 48. With the engine off, fill the cooling system with coolant at a constant minimum rate (typically 6 to 8 liters per minute) until it reaches the top of the filler neck or at the "Cold MAX" level.
 49. Prime the fuel system with fuel.



WARNING:
PERSONAL INJURY

To avoid injury before starting and running the engine, ensure the vehicle is parked on a level surface, parking brake is set, and the wheels are blocked.



WARNING:
ENGINE EXHAUST

To avoid injury from inhaling engine exhaust, always operate the engine in a well-ventilated area. Engine exhaust is toxic.

50. Start the engine (no coolant reservoir cap) and idle for one minute. Increase engine speed slowly to 1000-1200 rpm and hold for one minute. Then reduce engine speed to idle and cycle up and down between idle and 1000-1200 rpm for one additional minute.
51. After this three minute burp sequence, stop the engine and add coolant as required to achieve "Cold FULL" level. If a second top-off is needed, start the engine and idle the engine for one additional minute.
52. Stop the engine and add coolant as required to achieve the "Cold MAX" level, and then install the coolant reservoir cap.



WARNING:
PERSONAL INJURY

To avoid injury before starting and running the engine, ensure the vehicle is parked on a level surface, parking brake is set, and the wheels are blocked.



WARNING:
ENGINE EXHAUST

To avoid injury from inhaling engine exhaust, always operate the engine in a well-ventilated area. Engine exhaust is toxic.

NOTE:

This will eliminate the large pockets of air from the system, although smaller bubbles will still remain. Normal operation of the vehicle should purge the remaining air bubbles from the system without any damage. Extremely large cooling systems (such as in motor homes or luxury coaches) may require additional time for system deaeration.

53. Start the engine and inspect for leaks.



13400 Outer Drive, West, Detroit, Michigan 48239-4001
Telephone: 313-592-5000
WWW.DEMANDETROIT.COM

Specifications are subject to change without notice. Detroit Diesel Corporation is registered to ISO 9001:2008. Copyright © Detroit Diesel Corporation. All rights reserved. Detroit™ is a brand of Detroit Diesel Corporation, a Daimler company.

18SP720Rev 1610 As technical advances continue, specifications will change. Printed in U.S.A.