

January 19, 2016

01816 Version 3

Timing Belt Chirps

Supersedes 14-025, dated April 28, 2015, to revise the information highlighted in **yellow**

AFFECTED VEHICLES

Year	Model	Trim	VIN Range
2014–15	MDX	ALL	ALL
2016	MDX	2WD	5FRYD3...GB000001 thru 5FRYD3...GB008556
2016	MDX	AWD	5FRYD4...GB000001 thru 5FRYD4...GB032107
2014–15	RLX	ALL except Hybrid	ALL
2016	RLX	ALL except Hybrid	JH4KC1...GC000001 thru JH4KC1...GC000922
2015	TLX	2WD	19UUB2...FA000001 thru 19UUB2...FA025139
2015	TLX	AWD	19UUB3...FA000001 thru 19UUB3...FA010310

REVISION SUMMARY

Under AFFECTED VEHICLES, VINs have been added.

SYMPTOM

The timing belt area makes a chirp after the engine warms up.

POSSIBLE CAUSES

The timing belt contacts the back edge of the crankshaft pulley.

CORRECTIVE ACTION

Do the diagnosis and, based on the results, install an idler pulley shim.

PARTS INFORMATION

Required Parts for all models:

Part Name	Part Number	Quantity
Idler Pulley Shim	14559-RCA-305	1
Timing Belt Idler Bolt	14551-RCA-A01	1
Flange Bolt 10 mm x 60 mm	90168-TA1-A00	2
Flange Bolt 10 mm x 85 mm	90002-R70-A00	1
Flange Bolt 10 mm x 105 mm	95801-10105-08	2

For MDX, add the following:

Part Name	Part Number	Quantity
O-Ring	91319-R70-A01	1
Flange Bolt 12 mm x 45 mm	90165-SDA-A00	1

CLIENT INFORMATION: The information in this bulletin is intended for use only by skilled technicians who have the proper tools, equipment, and training to correctly and safely maintain your vehicle. These procedures should not be attempted by "do-it-yourselfers," and you should not assume this bulletin applies to your vehicle, or that your vehicle has the condition described. To determine whether this information applies, contact an authorized Acura automobile dealer.

For RLX, add the following:

Part Name	Part Number	Quantity
O-Ring	91319-PAA-A01	1
Flange Bolt 12 mm x 45 mm	90161-SDA-A01	1

For TLX, add the following:

Part Name	Part Number	Quantity
O-Ring	91319-R70-A01	1
Flange Bolt 12 mm x 45 mm	90161-SDA-A01	1

REQUIRED TOOLS

Part Name	Tool Number	Quantity
Holder Handle	07JAB-001020B	1
Pulley Holder	07MAB-PY3010A	1
Breaker Bar (commercially available)	07JAA-001020A	1

WARRANTY CLAIM INFORMATION

The normal warranty applies.

Model	Operation Number	Description	Flat Rate Time	Template ID	Failed Part Number
MDX	1110A7	Diagnose, and install an idler pulley shim.	2.5 hours	14-025N	14400-R9P-A01
RLX	1110A7	Diagnose, and install an idler pulley shim.	2.5 hours	14-025P	14400-R9P-A01
TLX	1110A7	Diagnose, and install an idler pulley shim.	2.5 hours	14-025Q	14400-R9P-A01

Defect Code: 07403

Symptom Code: 04201

Skill Level: Repair Technician

DIAGNOSIS

NOTE: During the diagnosis and repair, you will do the basic procedures listed below. For more detail about any of these procedures, see the electronic service manual.

- Wheel Removal and Installation
- Engine Undercover Removal and Installation
- Drive Belt Removal and Installation
- Crankshaft Pulley Removal and Installation
- Timing Belt Removal and Installation
- Side Engine Mount Removal and Installation
- Timing Belt Auto-Tensioner Removal and Installation

1. Start the engine, let it warm up, and listen for a chirp.

NOTE: It can take up to 30 minutes for the engine to become hot enough to hear a chirp.

Do you hear a chirp?

YES - If you hear a chirp, go to step 2.

NO - If you do not hear a chirp, this bulletin does not apply. Continue with normal troubleshooting procedures.

2. Remove the drive belt and retest the engine while it is hot.
 - If you hear a chirp, go to step 3.
 - If you do not hear a chirp, this bulletin does not apply. Continue with normal troubleshooting procedures.
3. Remove the right front wheel.
4. Remove the engine undercover.

MDX:

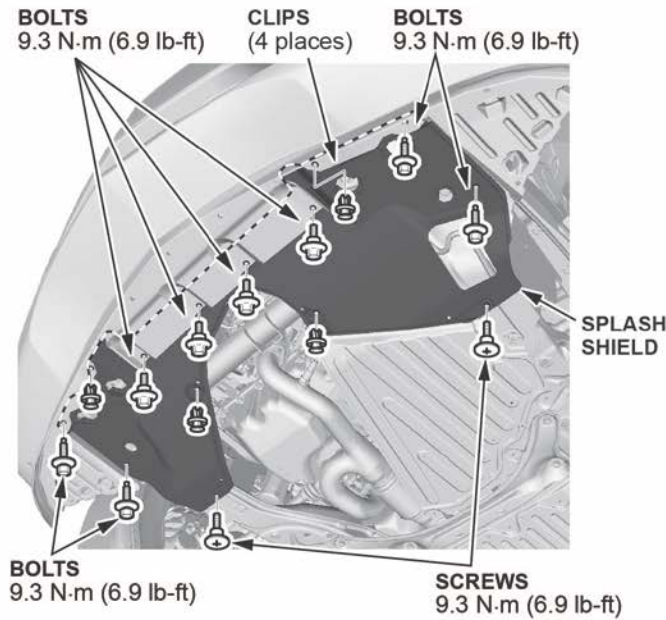

RLX:

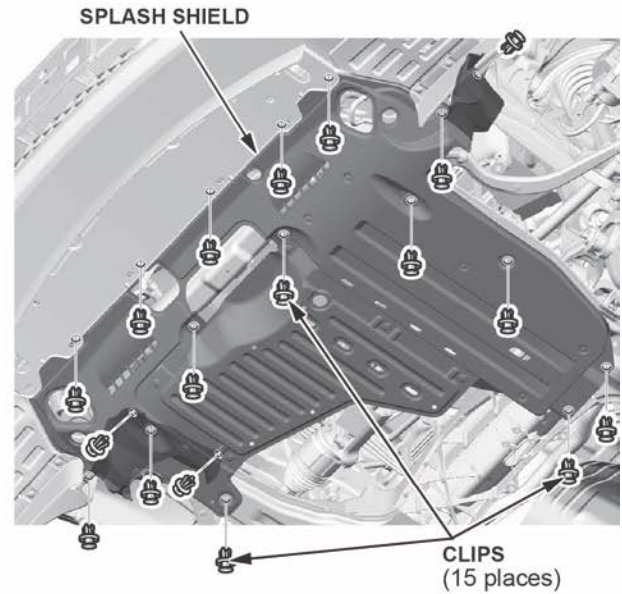

TLX:

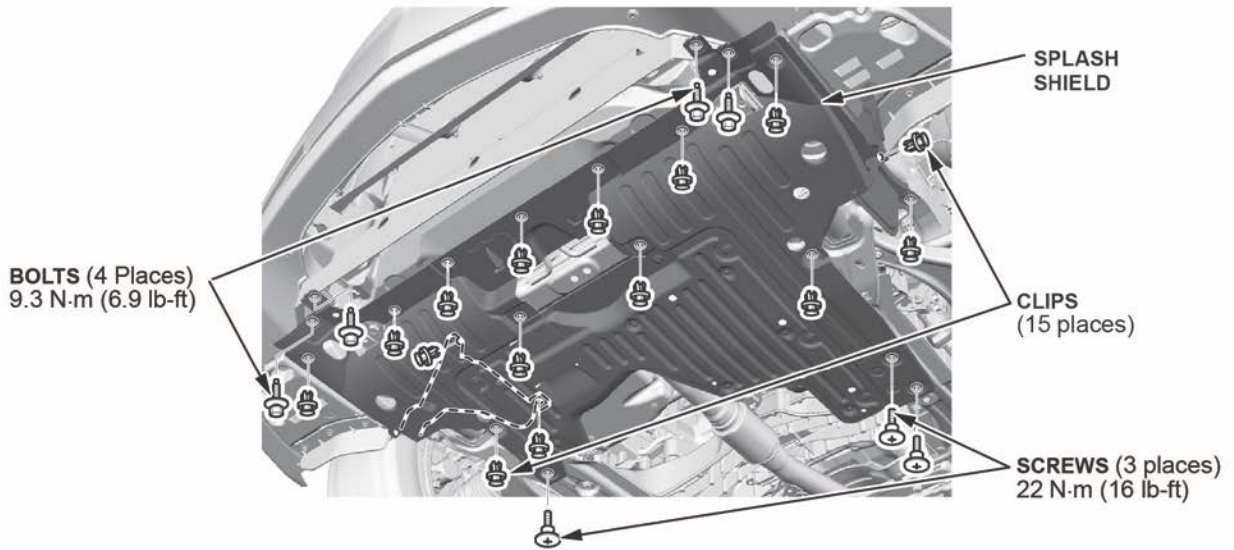

5. Hold the crankshaft pulley with the holder handle and the pulley holder.

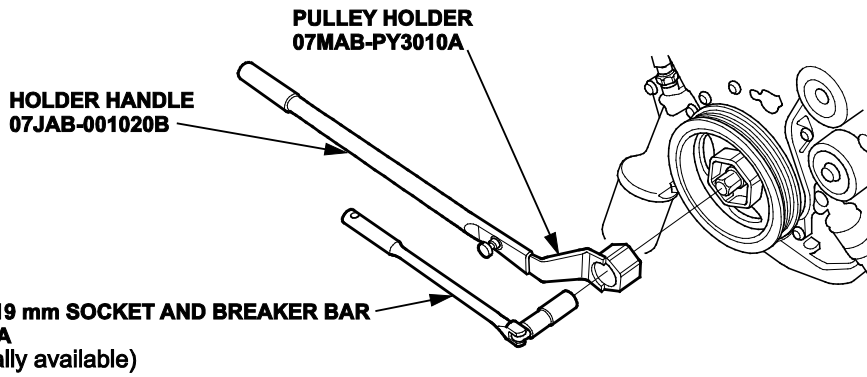

6. Remove the crankshaft bolt with a heavy duty 19 mm socket and a breaker bar, then remove the crankshaft pulley and washer. Temporarily reinstall the crankshaft bolt.

7. Remove the front and rear upper covers.

NOTE: Keep the A/C pressure sensor harness out of the way of moving parts by attaching it to the A/C line with a zip tie.

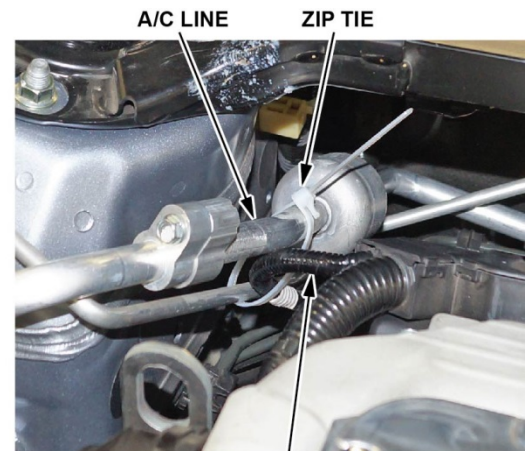
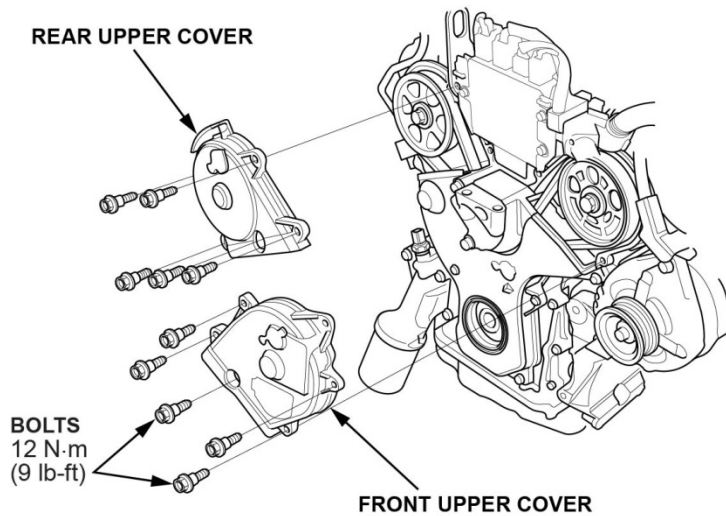

A/C PRESSURE SENSOR HARNESS

8. Remove the lower cover.

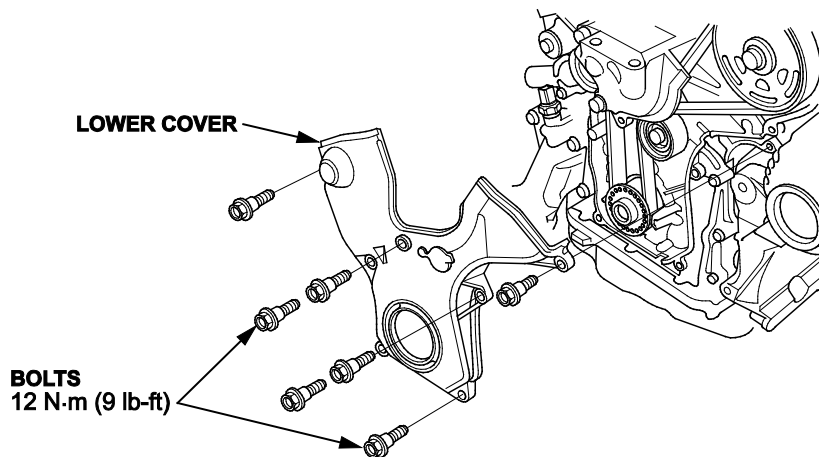

9. Start the engine while it is still hot, then spray the back edge of the timing belt with water while it is running.

Do you still hear a chirp?

- If the chirp lessens, changes pitch, or goes away, go to REPAIR PROCEDURE.
- If the chirp does not change, this bulletin does not apply. Continue with normal troubleshooting procedures.



REPAIR PROCEDURE

1. Try to insert a 0.95 mm feeler gauge between the top edge of the timing belt idler pulley and the back side of the side engine mount bracket that overhangs the pulley.

NOTE: Make sure you remove the feeler gauge from its holder to get a more accurate measurement.

- If you can insert the feeler gauge between the timing belt idler pulley and engine mount bracket, go to step 4.
- If you cannot insert the feeler gauge, go to step 2.

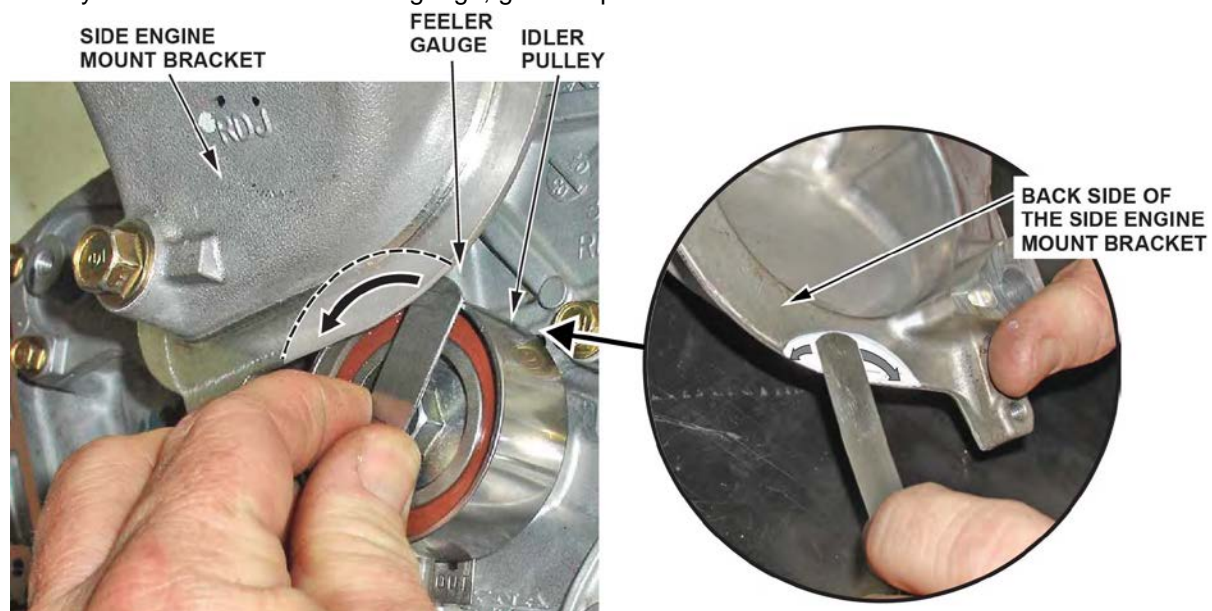

- Remove the side engine mount bracket.

UPPER HALF OF SIDE ENGINE MOUNT

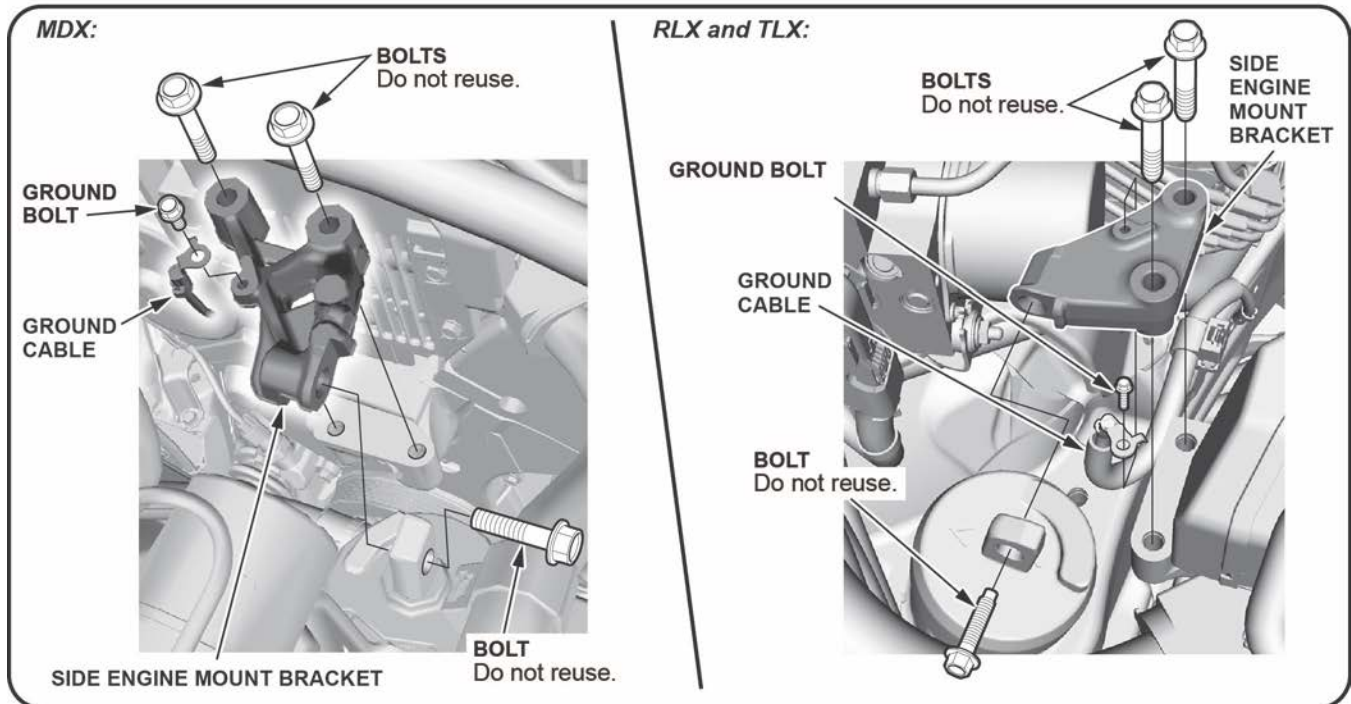

LOWER HALF OF SIDE ENGINE MOUNT

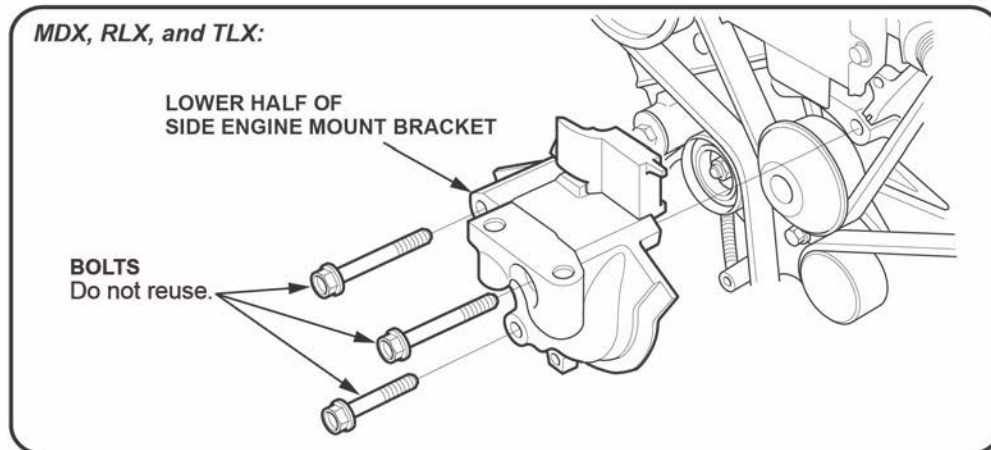

- Using a die grinder with a 2-inch grinding disc, use the circular casting offset as a guide to grind the side engine mount bracket until the lip measures 2 mm in thickness.

NOTE: Use a vernier caliper or micrometer to confirm the amount of material removed.

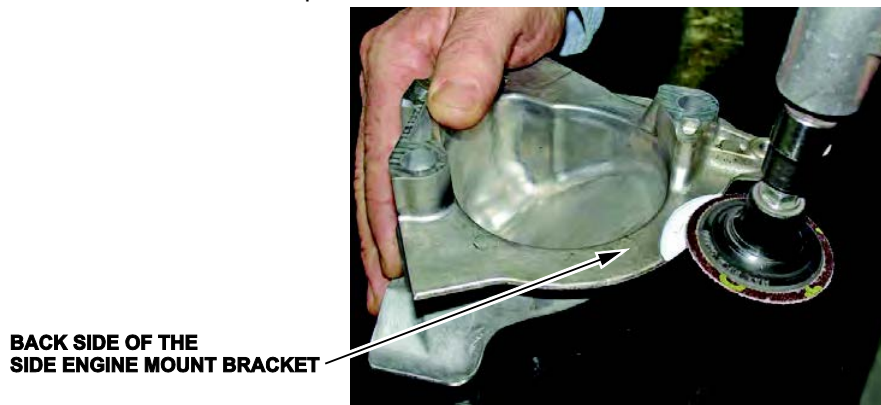

4. Set the engine to TDC (top dead center).
- Align the TDC mark on the tooth of the timing belt drive pulley with the pointer on the oil pump.

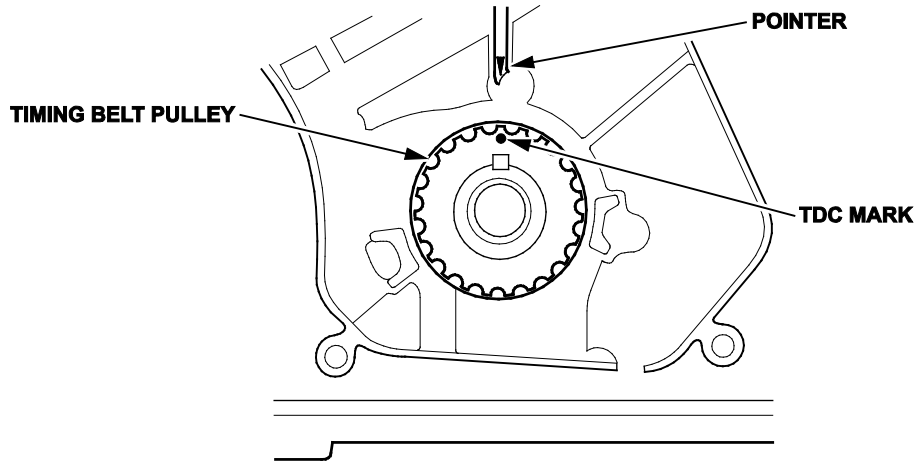

- Align the TDC marks on the camshaft pulleys with the pointers on the back covers.

REAR:

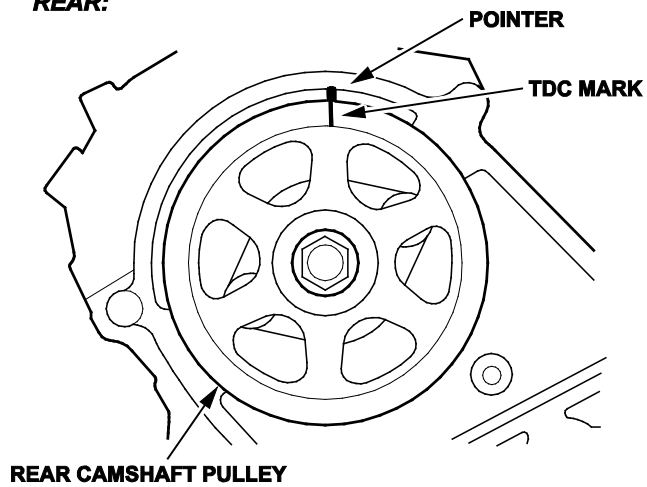

REAR CAMSHAFT PULLEY

FRONT:

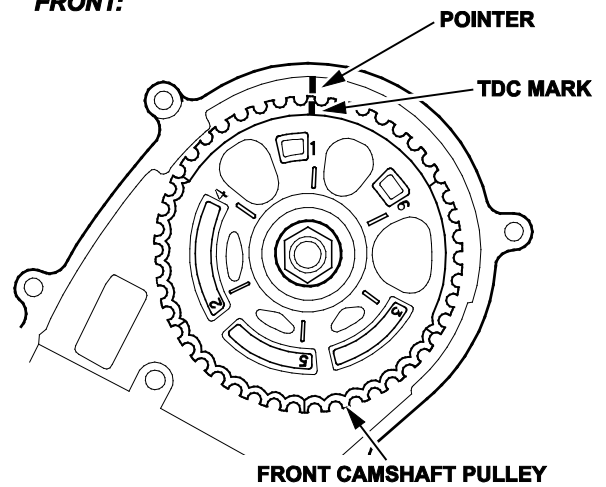

FRONT CAMSHAFT PULLEY

5. Thread and hand-tighten a battery clamp bolt as shown to hold the timing belt adjuster in its current position.
- NOTE: Do not use a wrench to tighten the battery clamp bolt.

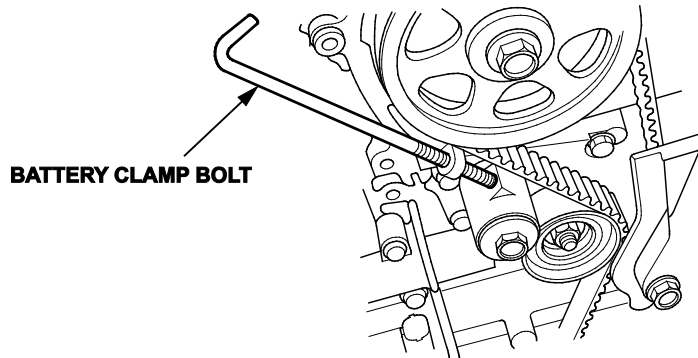

6. Remove the idler pulley.

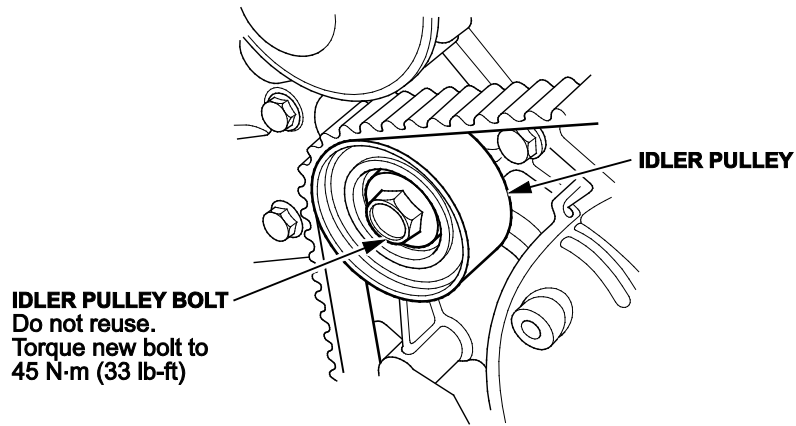

7. Remove the timing belt.

8. Remove the rocker arm oil pressure sensor from the oil filter housing to access the timing belt auto-tensioner bolts.

- Disconnect the rocker arm oil pressure sensor connector.
- Remove the rocker arm oil pressure sensor.
- Remove any old liquid gasket from the switch and the switch mounting hole.

MDX:

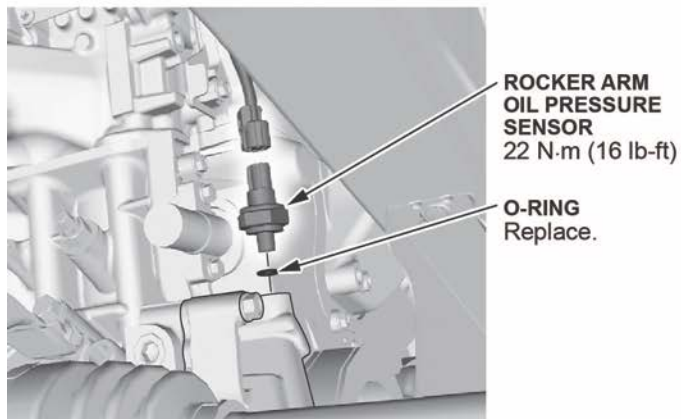

RLX and TLX:

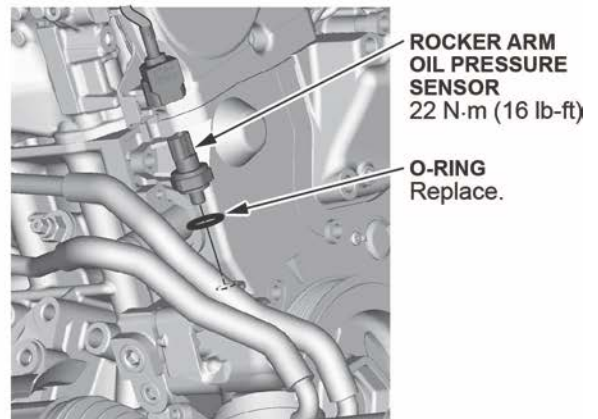

9. Remove the battery clamp bolt from the timing belt adjuster, then remove the timing belt auto-tensioner.

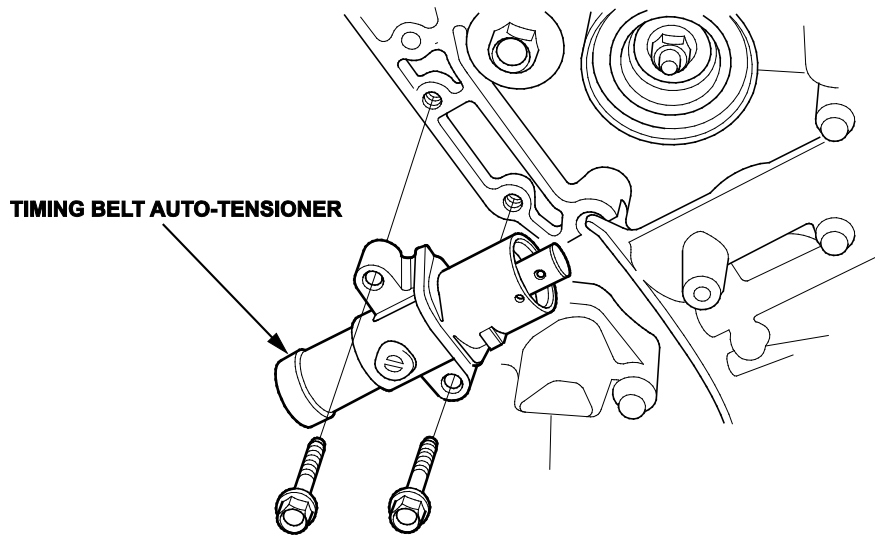

10. Place the idler pulley shim between the idler pulley and the oil pump housing; loosely install the new idler pulley bolt with Hondalock 1 applied to its threads. Make sure you follow the instructions on the Hondalock 1 container.

NOTE: The shim is tapered from left to right. The word **OUT** is stamped into the tang and painted white. It should be readable after the shim is installed.

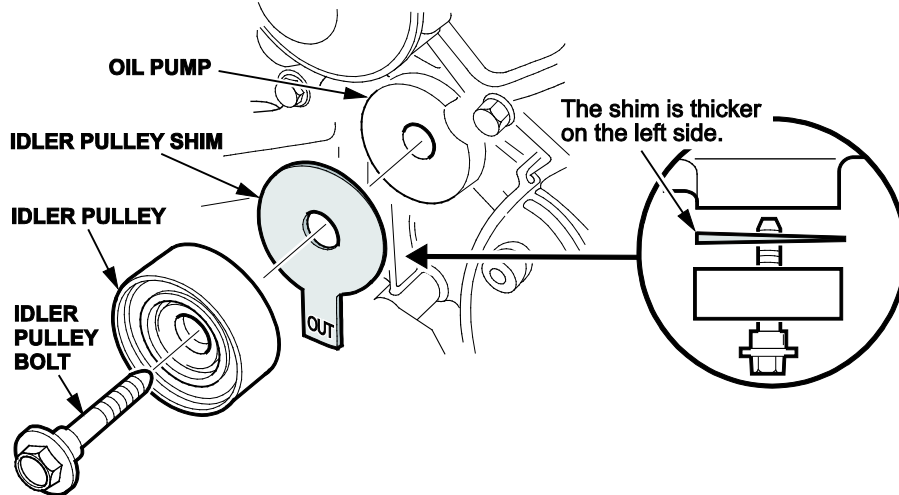

11. Install the new idler pulley bolt:

- Insert the square end of a 1/4-inch-drive ratchet extension to keep the shim's tang in the correct position.

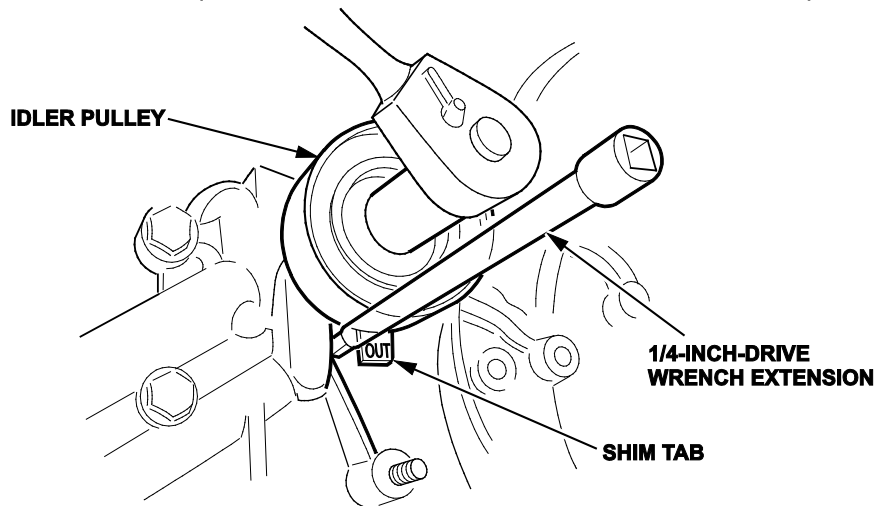

- Tighten the idler pulley bolt to **44 N·m (33 lb-ft)**.
- Bend the shim's tang slightly towards the oil pump housing to keep it away from the idler pulley.

12. Compress the timing belt auto tensioner.

- Align the holes on the rod and timing belt auto-tensioner housing.
- Use a hydraulic press to slowly compress the timing belt auto-tensioner. Insert a 2 mm (5/64 in) pin through the housing and the rod.

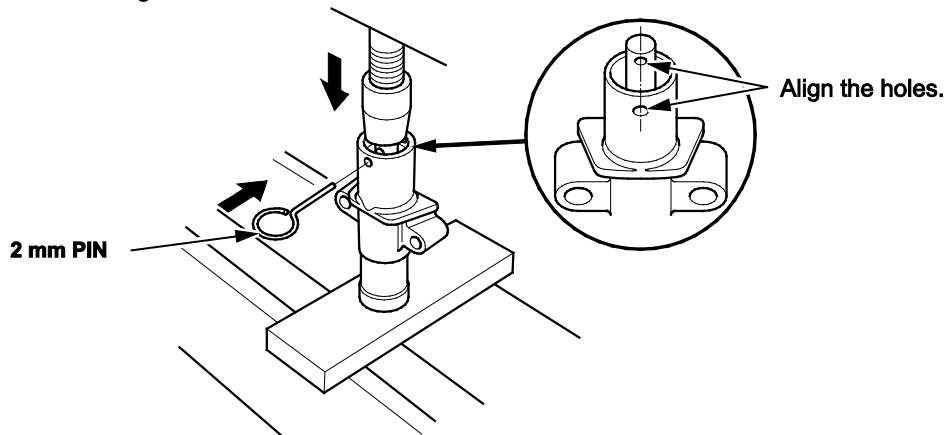

13. Thread and hand-tighten a battery clamp bolt to hold the timing belt adjuster.

NOTE: Do not use a wrench to tighten the battery clamp bolt.

14. Reinstall the timing belt auto-tensioner. Do not remove the pin.

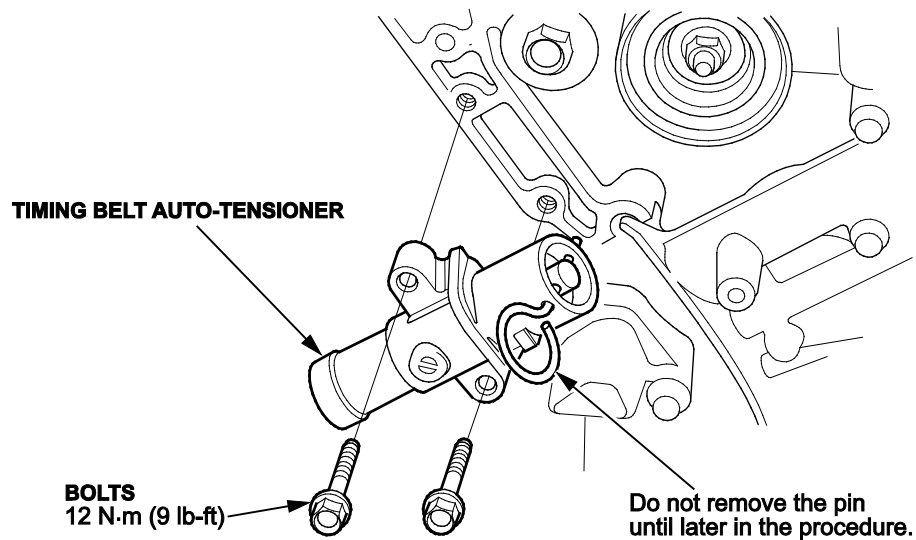

15. Reinstall the rocker arm oil pressure sensor.

- Apply Hondabond 4 liquid gasket to the rocker arm oil pressure sensor threads.
NOTE: Do not use too much liquid gasket because excessive liquid may enter the oil passages or block the end of the sensor.
- Install the rocker arm oil pressure switch with a new O-ring.
- Connect the rocker arm oil pressure switch connector.

16. Reinstall the timing belt.

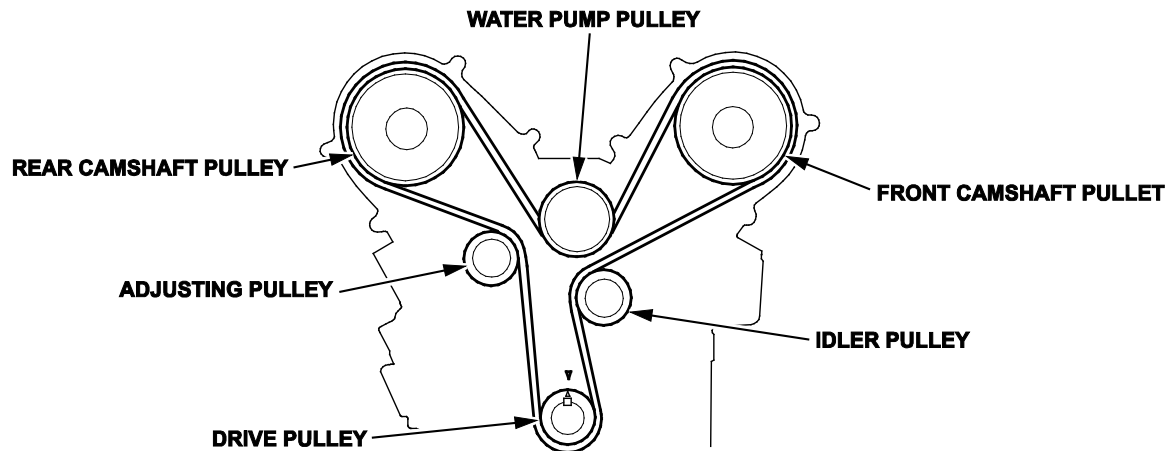

17. Remove the pin from the timing belt auto-tensioner.

18. Remove the battery clamp bolt from the timing belt adjuster and return it to its original location.

19. Reinstall the side engine mount with the new bolts and torque them as shown.

LOWER HALF OF SIDE ENGINE MOUNT

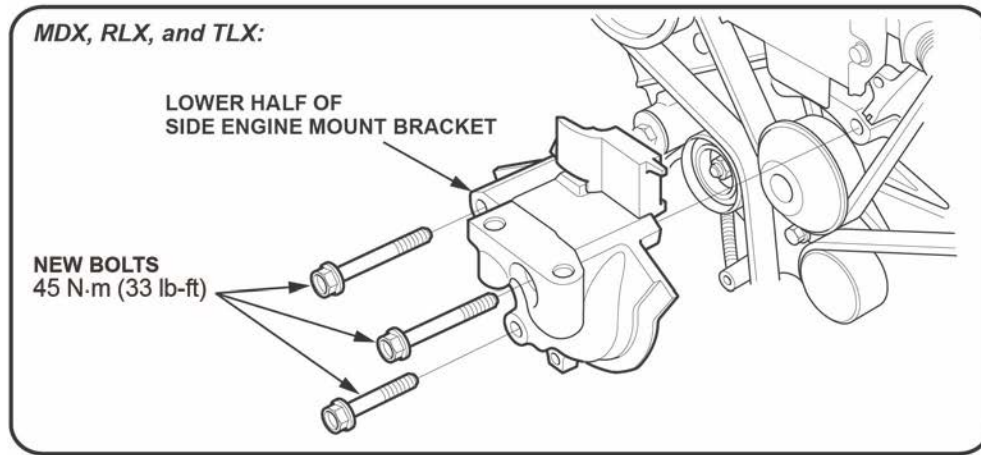

UPPER HALF OF SIDE ENGINE MOUNT

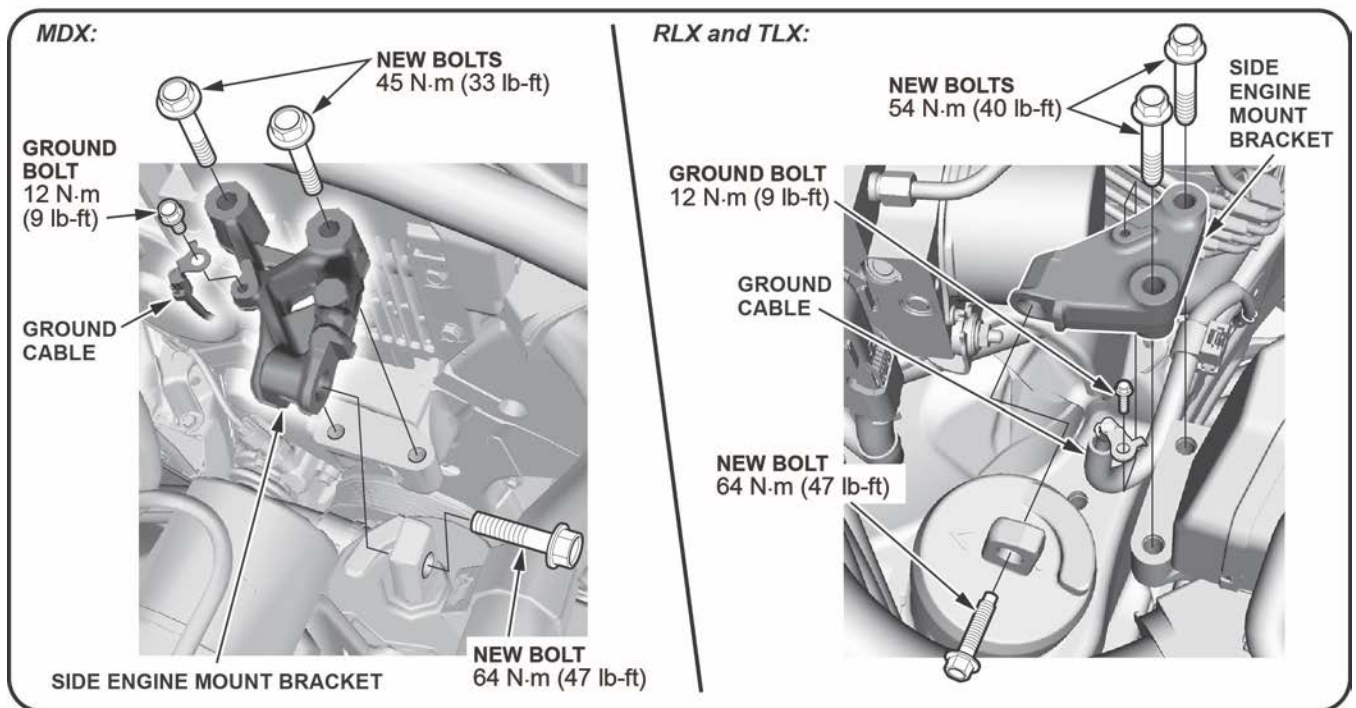

20. Install the upper and lower covers.

21. Remove the crank pulley bolt.

22. Remove any oil and clean the crankshaft pulley, washer, and bolt. Lubricate with new engine oil as shown.

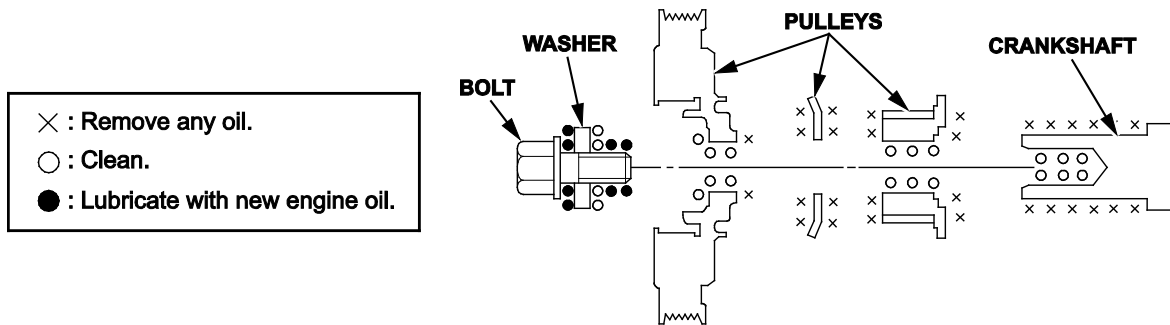

23. Install the crankshaft pulley and torque the bolt to **65 N·m (48 lb-ft)**.
24. Tighten the bolt an additional 60 degrees.

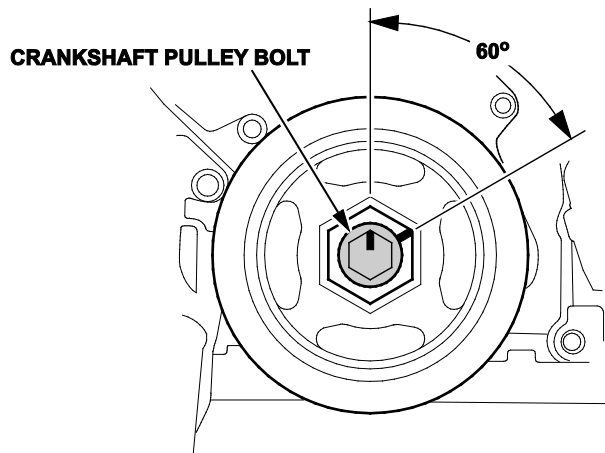

25. Install the drive belt.
26. Install the engine undercover.
27. Install the right front wheel and torque the nuts.
 - RLX: **127 N·m (94 lb-ft)**
 - MDX: and TLX: **108 N·m (80 lb-ft)**
28. Do the CKP pattern clear and the CKP pattern learn procedure.

NOTE: If you do not do these procedures, the PCM may falsely detect a misfire and set a DTC when there is no misfire.

END