

TECHNICAL BULLETIN

LTB00902NAS4

05 AUG 2016



© Jaguar Land Rover North America, LLC

NOTE: The information in Technical Bulletins is intended for use by trained, professional Technicians with the knowledge, tools, and equipment required to do the job properly and safely. It informs these Technicians of conditions that may occur on some vehicles, or provides information that could assist in proper vehicle service. The procedures should not be performed by 'do-it-yourselfers'. If you are not a Retailer, do not assume that a condition described affects your vehicle. Contact an authorized Land Rover service facility to determine whether this bulletin applies to a specific vehicle.

This reissue replaces all previous versions. Please destroy all previous versions.

Changes are highlighted in gray

SECTION: 309-00

Engine MIL Illuminated With DTC P2096-00 or P2097-00 Stored

AFFECTED VEHICLE RANGE:

Discovery Sport (LC)

Model Year: 2016

VIN: 544577-605042

GTDi 2.0L Petrol/GTDi 2.0L Petrol - SULEV

Assembly Plant: Halewood

Range Rover Evoque (LV)

Model Year: 2014-2016

VIN: 856580-134807

GTDi 2.0L Petrol/GTDi 2.0L Petrol - SULEV

Assembly Plant: Halewood

MARKETS:

NAS

CONDITION SUMMARY:

Situation: The engine Malfunction Indicator Lamp (MIL) may be illuminated with Diagnostic Trouble Code (DTC) P2096-00 or P2097-00 stored in the Powertrain Control Module (PCM).

After DTC P2096-00 or P2097-00 is stored, one or more of the following misfire-related DTCs is also likely to be stored in the PCM: P0300-00, P0301-00, P0302-00, P0303-00, and/or P0304-00.

Cause: This may be caused by a PCM software error.

Action: If the snapshot data show that one or more of the misfire-related DTCs has set **AFTER** DTC P2096-00 or P2097-00 is stored, follow the Service Instruction for DTC P2096-00 or P2097-00 outlined below.

If the snapshot data show that one or more of the misfire-related DTCs has set **BEFORE** DTC P2096-00 or P2097-00 is stored, investigate as per normal diagnostics. To be performed as a separate claim.

PARTS:

No Parts Required

TOOLS:



E179225

Jaguar Land Rover-approved diagnostic tool with latest DVD and Calibration File

Jaguar Land Rover-approved Midtronics battery power supply



E192494

Refer to the Service Instruction/Workshop Manual for any required special tools.

High Pressure Diagnostic Leak Detector
95-0106



E184192

WARRANTY:

⚠ **NOTE:** Repair procedures are under constant review, and therefore times are subject to change; those quoted here must be taken as guidance only. Always refer to TOPIx to obtain the latest repair time.

⚠ **NOTE:** DDW requires the use of causal part numbers. Labor only claims must show the causal part number with a quantity of zero.

DESCRIPTION	SRO	TIME (HOURS)	CONDITION CODE	CAUSAL PART
Reconfigure the Powertrain Control Module	12.90.13	0.2	04	LR057872
High Pressure Diagnostic Leak Detector test - With exhaust installed	30.10.89.49	0.6	04	LR057872

⚠ **NOTE:** Normal Warranty procedures apply.

SERVICE INSTRUCTION:

⚠ **NOTE:** Some variation in the illustrations may occur, but the essential information is always correct.

1. Reposition the air intake pipe.

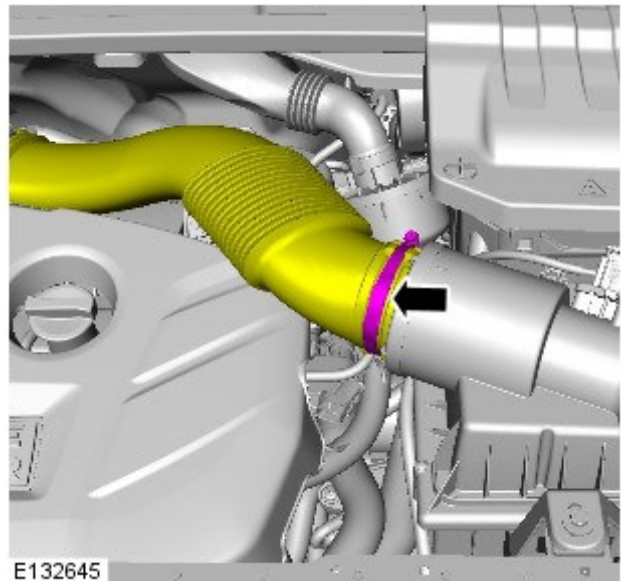

2. **WARNING:** Use the adapters supplied in the High Pressure Diagnostic Leak Detector kit.

Insert a suitable air intake adapter and a suitable block-off coupler to block off the inlet pipe.

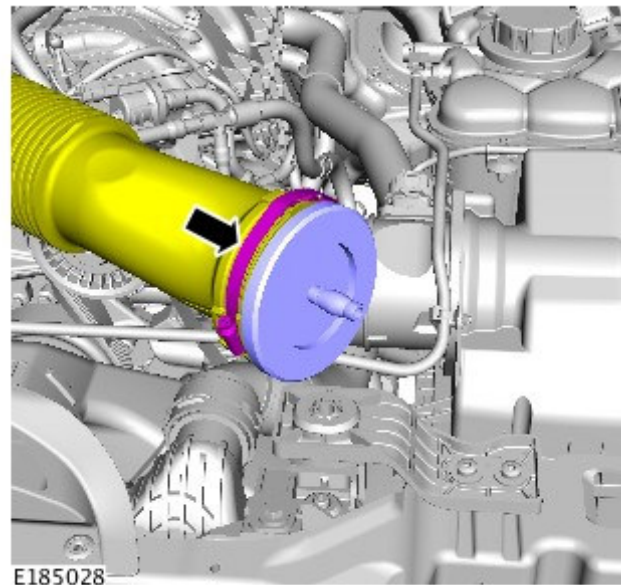

3. **CAUTION:** Never use dye/Ultraviolet (UV) dye in intake or exhaust systems; it may coat or harm critical sensors.

NOTE: Maximum to refill when empty: 2 fl. oz. (60 ml) .

Check and top up (if required) the vapor producing fluid reservoir.

4. **CAUTION:** Do not connect the High Pressure Diagnostic Leak Detector to a battery charger, battery support unit, or jumper box.

CAUTION: Never connect the High Pressure Diagnostic Leak Detector to the vehicle with the engine running.

Connect the High Pressure Diagnostic Leak Detector to a suitable power supply.

5. Connect the High Pressure Diagnostic Leak Detector to a suitable air supply.
6. Switch the flow control valve to the OFF position.

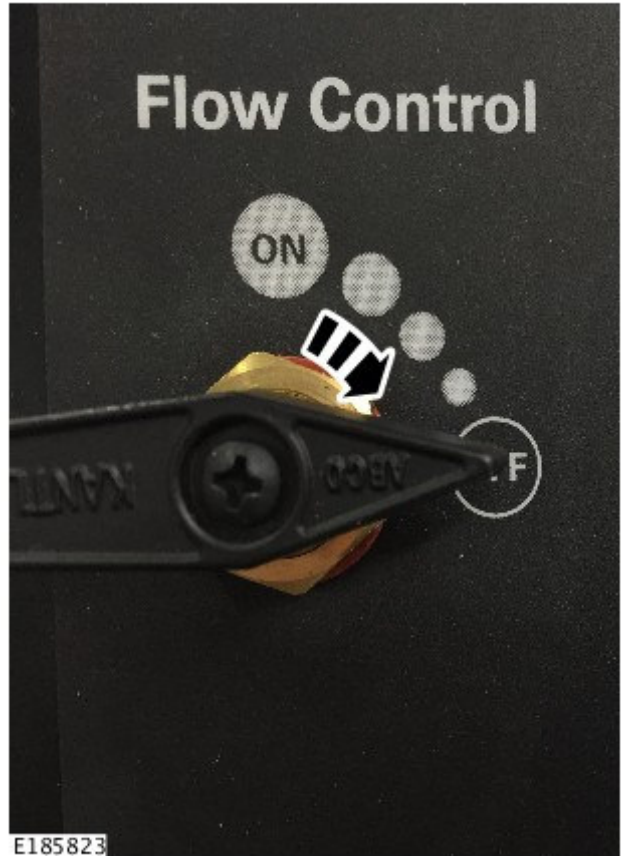

7. Pull the pressure regulator valve OUT.

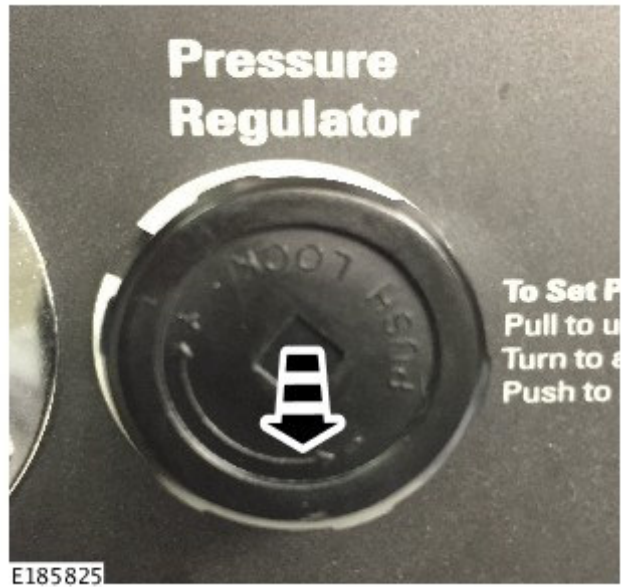

8.  **CAUTION: Do not exceed 0.5 bar (7.5 psi) test pressure or damage to components can occur.**

Use the 'Pressure Regulator' adjuster to set the test pressure to 0.5 bar (7.5 psi).



9. Push the pressure regulator valve IN to lock it.



10. Insert the leak detector's PowerSmoke™ adapter into the tailpipe.



11. Connect the block-off coupler to one of the tail pipe PowerSmoke™ adapters. Use a suitable tire inflator to inflate

the tailpipe PowerSmoke™ adapter bladder.

- Connect the leak detector to the other tailpipe. Use a suitable tire inflator to inflate the tailpipe PowerSmoke™ adapter bladder.

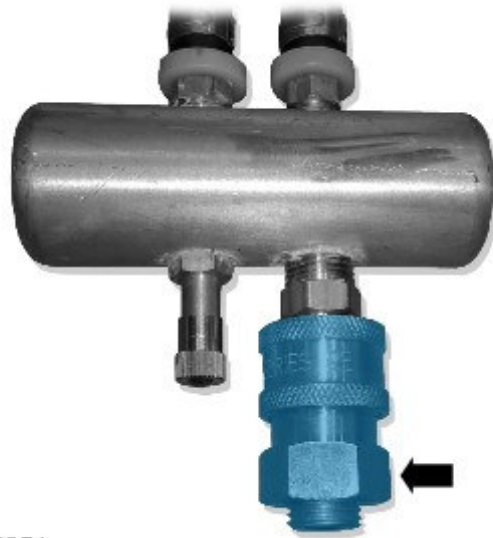

E188274

12. Press the START switch to begin a 10-minute vapor cycle.

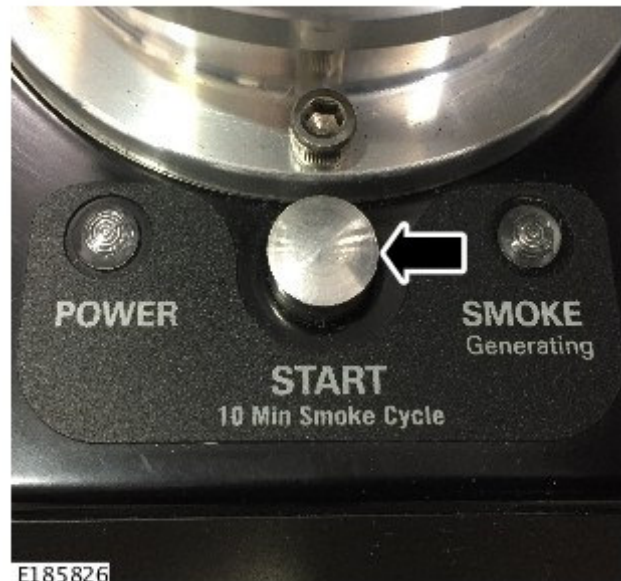

E185826

13. Turn the flow control valve ON to release pressure/vapor.

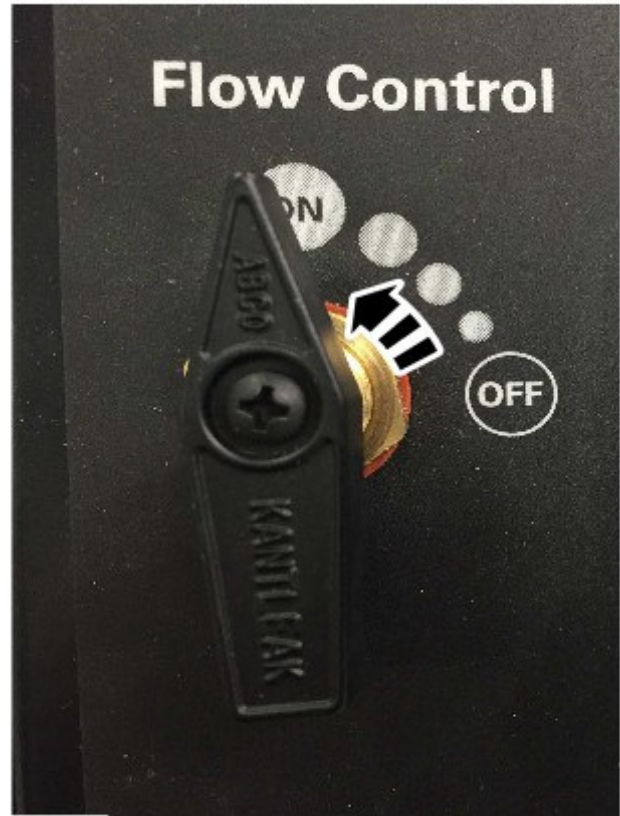

E185824

14.  **NOTE: Do not loosen the heated oxygen sensor (HO2S) before attempting to re-torque.**

Inspect the exhaust system for air leaks around **all** the HO2S and the exhaust.

- If a HO2S leak is found, torque the HO2S to the correct specification as shown in TOPIx.
- If a HO2S leak is not found, continue to the next step.

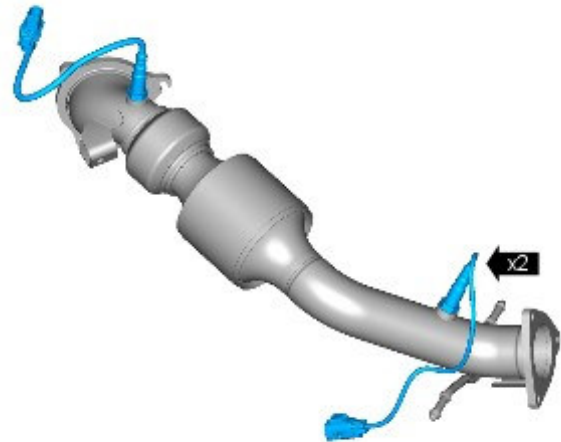

E133092

15.  **NOTE: Do not loosen the bolts before attempting to torque.**

Inspect the exhaust system for air leaks around the exhaust three-bolt flange:

- If an exhaust leak is found, tighten the bolts to the correct specification as shown in TOPIx.
- If an exhaust leak is not found, continue to Step 16.

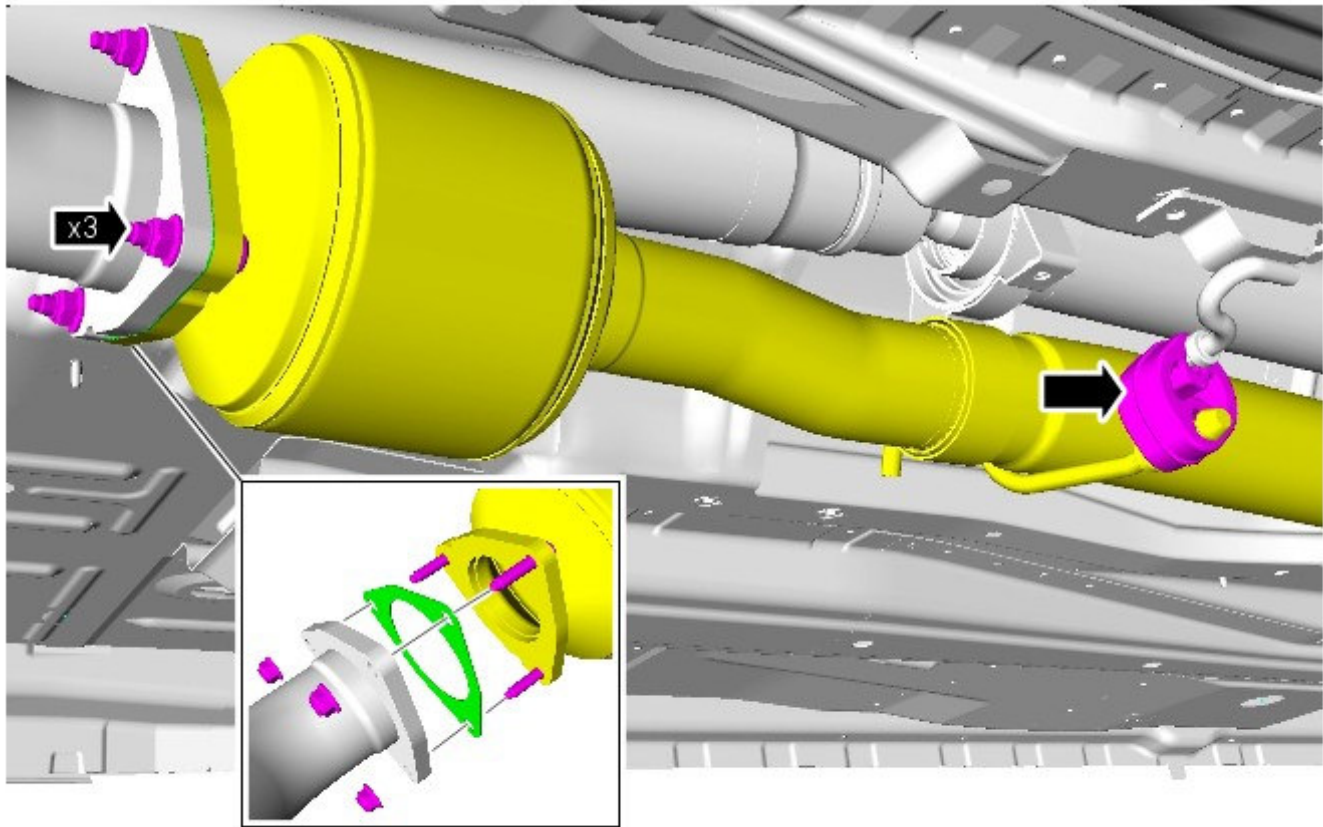

E138557

16. Install the air intake pipe.

- Torque: **3Nm**

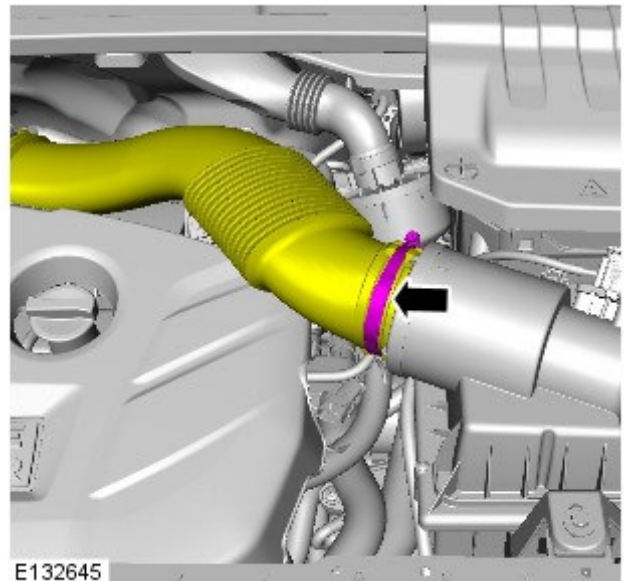

E132645

⚠ CAUTION: A Jaguar Land Rover-approved Midtronics battery power supply must be connected to the vehicle battery during diagnosis / module programming.

⚠ CAUTION: Ensure all ignition ON/OFF requests are carried out; failure to perform these steps may cause damage to control modules in the vehicle.

⚠ NOTE: The Jaguar Land Rover-approved diagnostic tool must be loaded with DVD145.04 v.245 or later.

17. Connect the Jaguar Land Rover-approved Midtronics battery power supply to the vehicle battery.

18. Turn ignition ON (engine not running).

19. Connect the Jaguar Land Rover-approved diagnostic tool to the vehicle and begin a new session.
20. Follow the on-screen prompts, allowing the diagnostic tool to read the VIN, identify the vehicle, and initiating the data collect sequence.
21. Select **Diagnosis** from the Session Type screen.
22. Select the **Selected Symptoms** tab and then select:
 - **Electrical - Instruments - Warning lamps - Engine malfunction lamp - Lamp illuminated**
23. Select continue'.
24. Select the **Recommendations** tab.
25. Select **Run** to perform the '**Configure existing module - Powertrain control module**' option.
26. Follow all on-screen instructions to complete this task, ensuring all Diagnostic Trouble Codes (DTC) are cleared.
27. When all tasks are complete, select the **Session** tab and then select the **Close Session** option.
28. Disconnect the diagnostic tool and battery power supply from the vehicle.