



Service Bulletin

File in Section: -

Bulletin No.: 16-NA-014

Date: July, 2016

TECHNICAL

Subject: Delayed Engagement After Sitting With Engine Off

Brand:	Model:	Model Year:		VIN:		Engine:	Transmission:			
		from	to	from	to					
Cadillac	Escalade	2015	2016	SOP	10/08/2015		8L90			
	Escalade ESV						8L90			
	ATS						8L45 or 8L90			
	CTS						8L45 or 8L90			
Chevrolet	Camaro				2015	2016	SOP	11/23/2015	3.6L (LGX)	8L90
								9/28/2015		8L45
	11/09/2015							2.0L (LTG)		8L45
	10/27/2015									8L90
	10/12/2015									8L90
Corvette									8L90	
Silverado									8L90	
GMC	Sierra				2015	2016	SOP	10/12/2015		8L90
	Yukon	8L90								
	Yukon XL	10/08/2015	8L90							

Involved Region or Country	North America and N.A. Export Regions
Condition	<p>Some customers may comment on a condition of delayed engagement when the transmission is shifted from Park to Reverse or Park to Drive after the vehicle has been sitting with the engine off. This condition may typically occur after several hours or more commonly overnight.</p> <p>Customers may describe this condition as:</p> <ul style="list-style-type: none"> • Vehicle delaying into gear. • Not wanting to move. • Feeling like the transmission is slipping. • Delayed engagement followed by a harsh engagement. <p>Operation will be normal for the subsequent engagements throughout the day and the condition will not occur until the vehicle sits again with the engine off for several hours or overnight.</p>
Cause	This condition may be caused by the torque converter draining the transmission fluid back into the transmission pan.

Not Wanting to Move or Slips - Torque Converter Drain Back

Vehicle Should Only be evaluate if sitting for 24 hours or Less.

Torque Converter Drain Down is present if the time difference between engine speed ramping up (Pt. 1) and transmission input shaft speed ramping up (Pt. 2) exceeds 2 seconds.

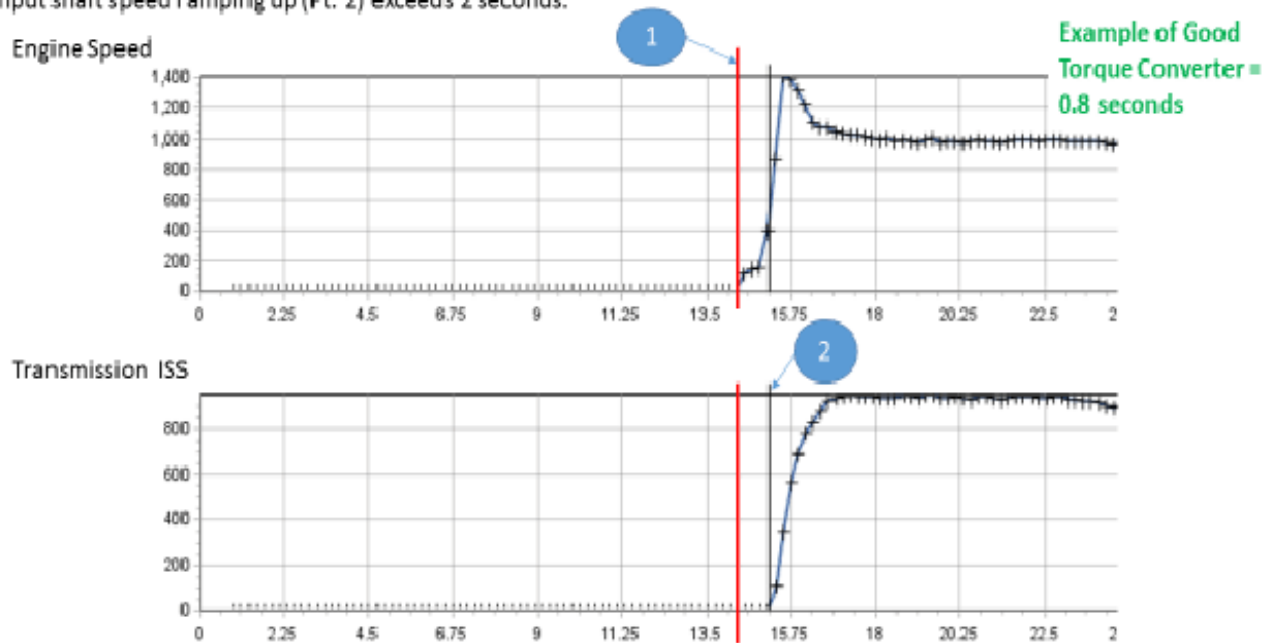

The slide bar on the bottom of GDS 2 screen can be used to aid in discerning time.

Example of acceptable torque converter fill time.

If the customer describes the condition as a long engagement with a slip/soft engagement feel and/or the vehicle not wanting to move, the condition should be considered drain back and the following procedure should be followed.

1. Using GDS and monitor engine RPM and transmission Input Speed Sensor (ISS) prior to starting the engine.
2. Start the engine with the transmission in park.
 - ISS should be equal to engine RPM in 3 seconds or less.
 - If ISS takes more than 3 seconds to equal engine RPM than follow the procedure for replacing the stator shaft support described in the service procedure below.
 - **DO NOT** replace the stator shaft support on vehicles taking 3 seconds or less for turbine shaft speed to equal engine RPM.

Delayed Harsh Engagement - Clutch Slow to Fill

Delayed Engagement into Reverse is present if the time difference between Gear Command (Pt. 1) and transmission input shaft speed reaching 0 rpms (Pt. 2) exceeds 1.5 seconds.

Example of C5 Needing to complete Adaptive Learn and several garage shifts in the temperature range of 20 – 30 deg C. = 3.34 seconds.

Gear Command

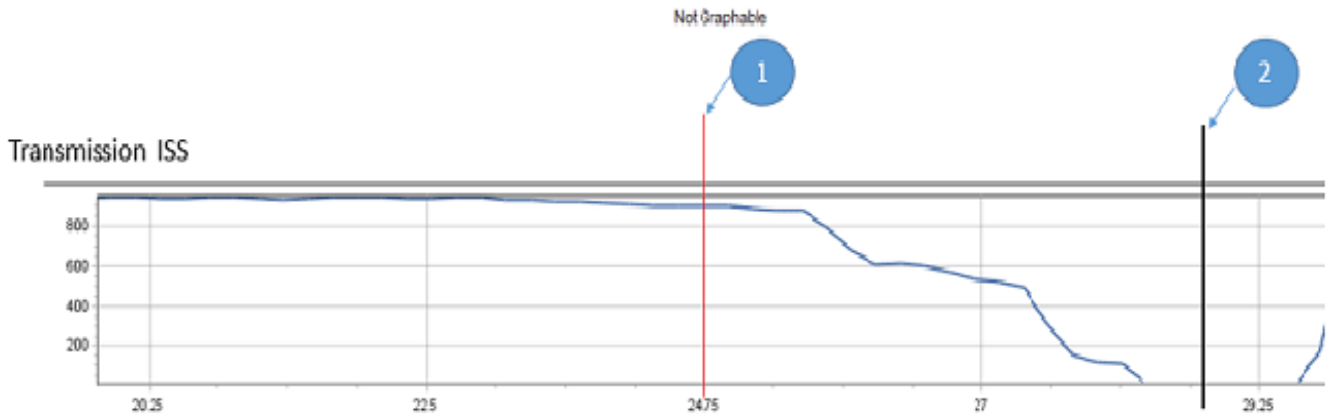

The slide bar on the bottom of GDS 2 screen can be used to aid in discerning time.

Example of C5 clutch needing to complete Adaptive Learn on a 2016 MY vehicle or a C5 Clutch that is slow to learn on 2015 and 2016 fill.

If the customer describes the condition as a long engagement time with a harsh or bump engagement feel when shifting the vehicle from park to drive or reverse. Using GDS and monitor engine RPM and transmission Input Speed Sensor (ISS) prior to starting the engine. Start the engine with the engine in park. ISS should equal engine RPM in 3 seconds or less. If ISS takes more than 3 seconds to equal engine RPM than follow the procedure for replacing the stator shaft support. If the ISS is equal to engine RPM in 3 seconds or less shift the vehicle from park to drive or reverse leaving the service brake applied. ISS should drop to zero "0" within 2 seconds, this is clutch engagement time. Recording a GDS session log can be useful in diagnosing this condition.

For 2015 MY vehicles Contact GM TAC for review and additional instructions. Prior to contacting TAC record a GDS2 Session log of the delayed engagement.

Note: This procedure will allow the pressures to adapt and improve the engagement time to reverse.

For 2016 MY vehicle attempt to learn the C5 Clutch using the following procedure:

1. Allow the transmission sump temperature to rise between 20 and 30 degrees C (68 and 86 degrees F).

Note: Do NOT apply the accelerator pedal.

2. Perform 20 Park to Reverse shifts releasing the brake with each shift.

If the learn procedure does not correct the condition contact GM TAC for review and additional instructions. Prior to contacting TAC record a GDS2 Session log of the delayed engagement.

Correction

Install a new stator shaft support assembly that includes an additional check ball. Follow the instructions below to replace the stator shaft support assembly.

Service Procedure

1. Remove the transmission from the vehicle and mount to the DT-48989 transmission holding fixture. Refer to *Transmission Replacement* in SI.
2. Remove the 15 bolts (1) securing the fluid pan and gasket to the transmission.

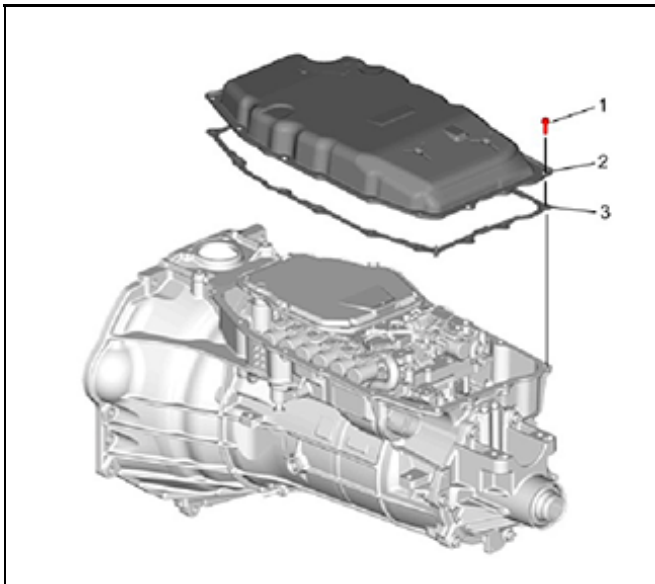

4358672

Note: The fluid pan gasket is reusable. Inspect the gasket to determine if it may be reused. If the gasket is stuck to the case or pan, it should be replaced.

3. Remove the fluid pan (2) and gasket (3). The fluid filter does not need to be removed.

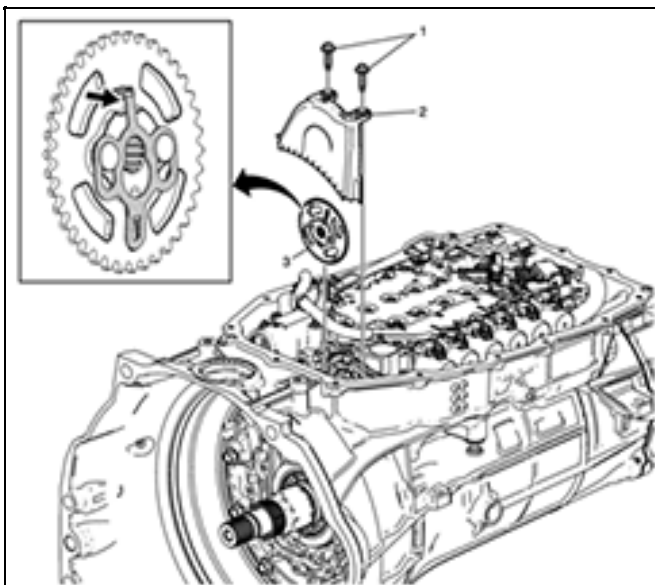

4358767

4. Using the DT-48285 Torx Plus socket, remove the two fluid baffle bolts (1) and fluid baffle (2). Discard the bolts.

Note: The driven sprocket locking tab is located on the back of the sprocket. Rotate the sprocket as shown and simultaneously pull back and up on the tab to release the retainer.

5. Remove the driven sprocket (3) from the oil pump shaft leaving the drive link (chain) loose in the case.

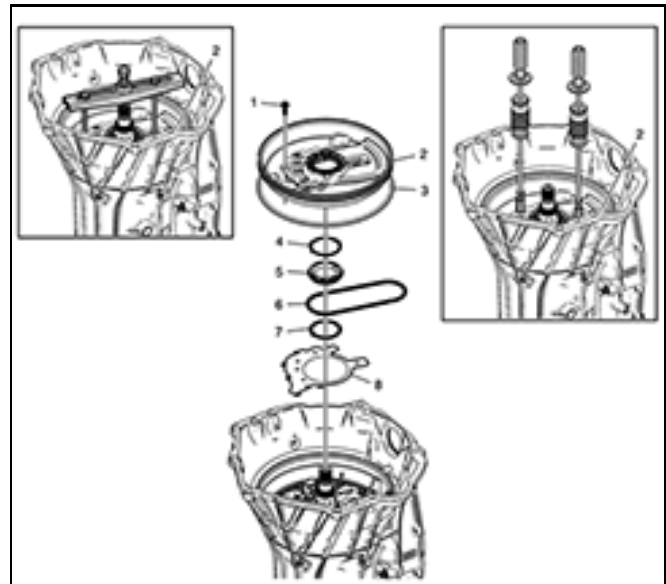

4358769

6. Remove the 11 front cover bolts (1). Discard the bolts. The bolts have a dry sealant on them and may only be used once.

Note: There are 2 different front cover configurations. Early design front covers have 3 threaded holes for service, late design front covers have 2 threaded holes.

- Use two *GE-6125-1B* slide hammers and *DT-51791* slide hammer adapters in the threaded holes of the front cover to remove it from the case for applications with 3 threaded holes.
- Use the *GE-8433* puller bar and 2 bolts in the threaded holes of the front cover to remove it from the case for applications with 2 threaded holes.

7. Remove the front cover (2) and seal (3). Inspect the seal and replace if worn or damaged.
8. Remove the drive sprocket (5).
9. Remove the drive link assembly (6).
10. Remove the front support cover gasket (8). Discard the gasket.
11. Inspect the front (4) and rear (7) drive sprocket thrust washers. Replace if worn or damaged.

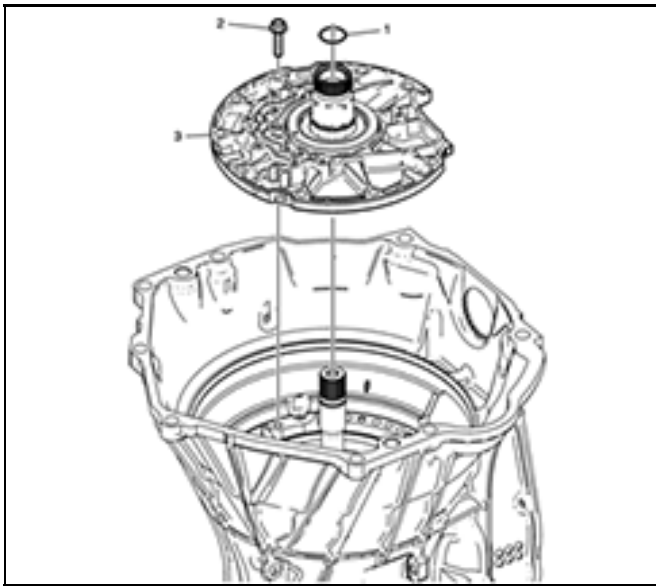

4358771

12. Remove the turbine shaft O-ring seal (1). Discard the seal.
13. Remove the nine stator shaft support bolts (2).
14. Remove the stator shaft support assembly (3).

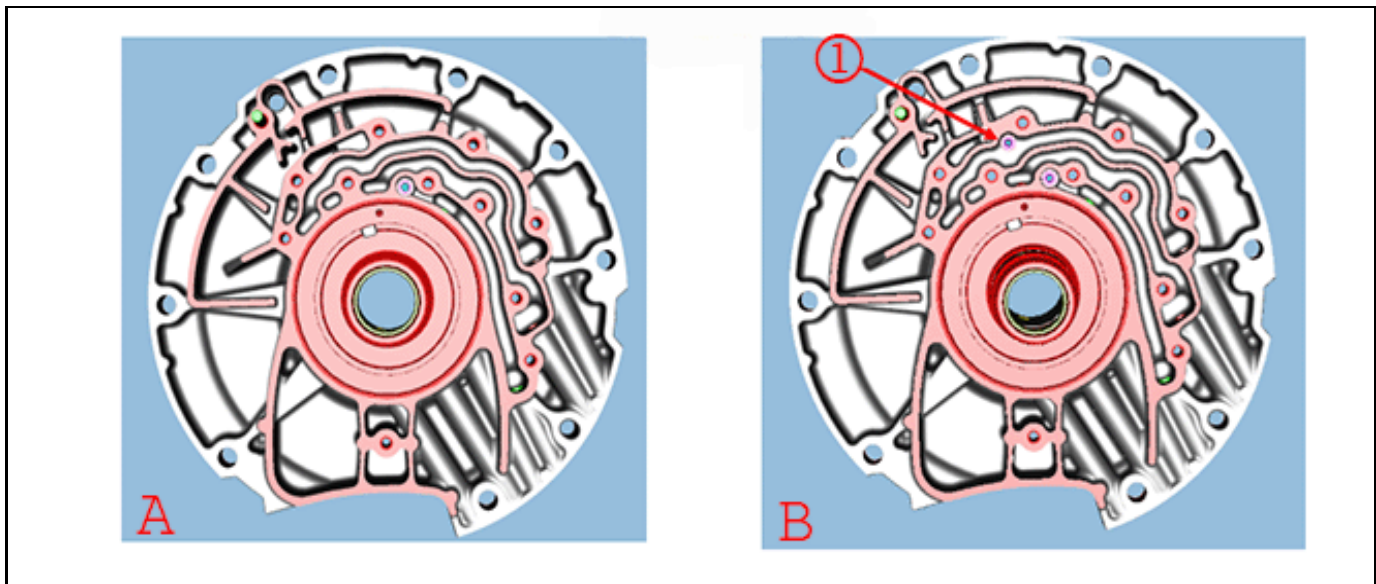

4358773

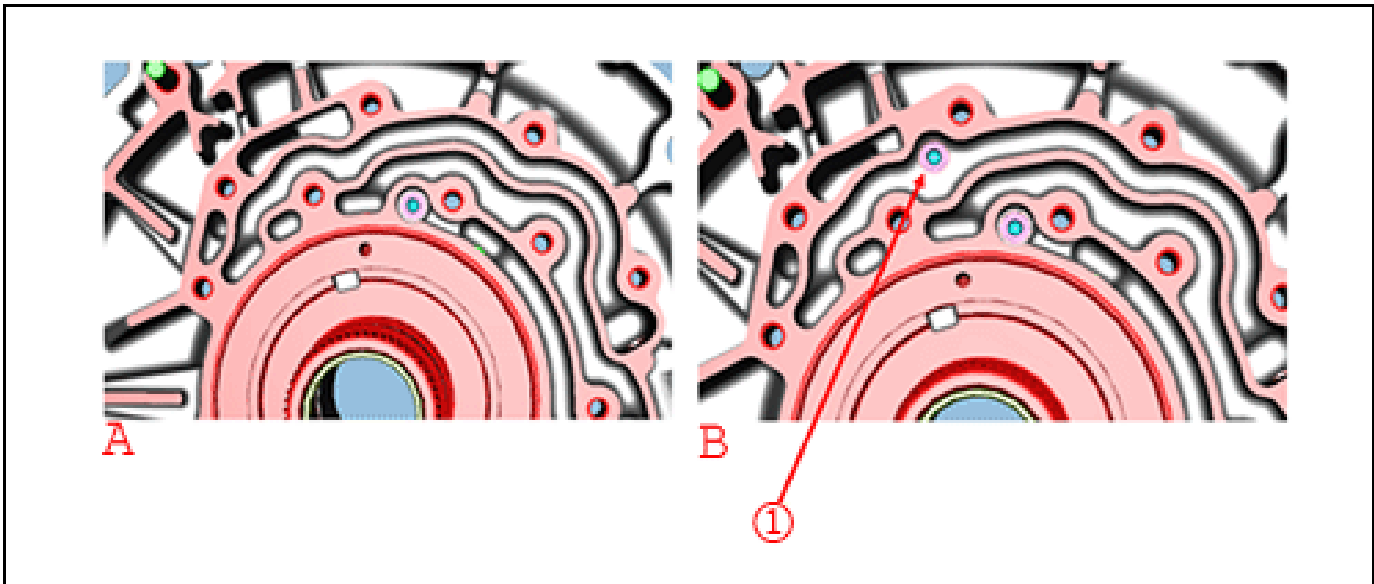

4358775

Legend

(A) Old stator support asm

(B) New stator support asm

Note: The new stator shaft support assembly has a second check ball (1) added (see illustrations).

Caution: Size the converter fluid seal ring for at least 5 minutes after installation to obtain proper seal ring size. Failure to do so may cause internal transmission leaks and transmission damage.

Note: Use the large taper side of *DT-50912-1* Seal Sizer for initial seal sizing, then flip the tool over for final sizing. The *DT-50912-1* seal sizer works for both the 8L90 and 8L45.

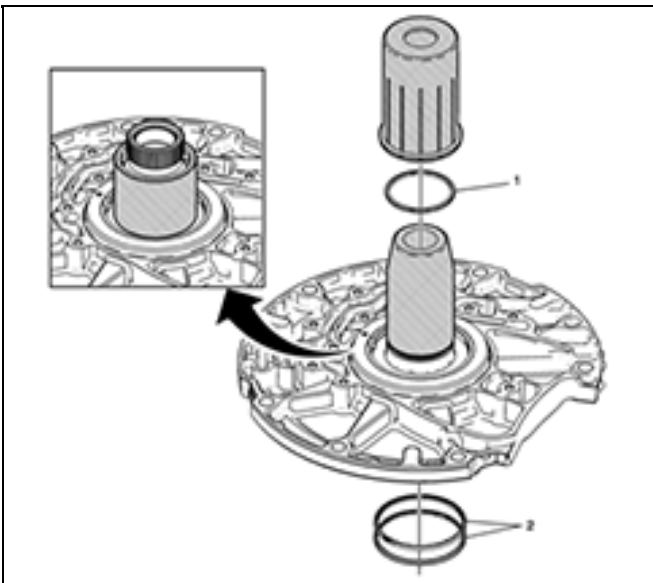

15. Using the *DT-50912* Seal Installer (8L90) or *DT-51196* Seal Installer (8L45), install a NEW torque converter fluid seal (1) on the stator shaft support assembly. Size the seal using the *DT-50912-1* Seal Sizer.
16. Install 2 NEW 1-3-5-6-7 Clutch Fluid Seal Rings (2).

4358778

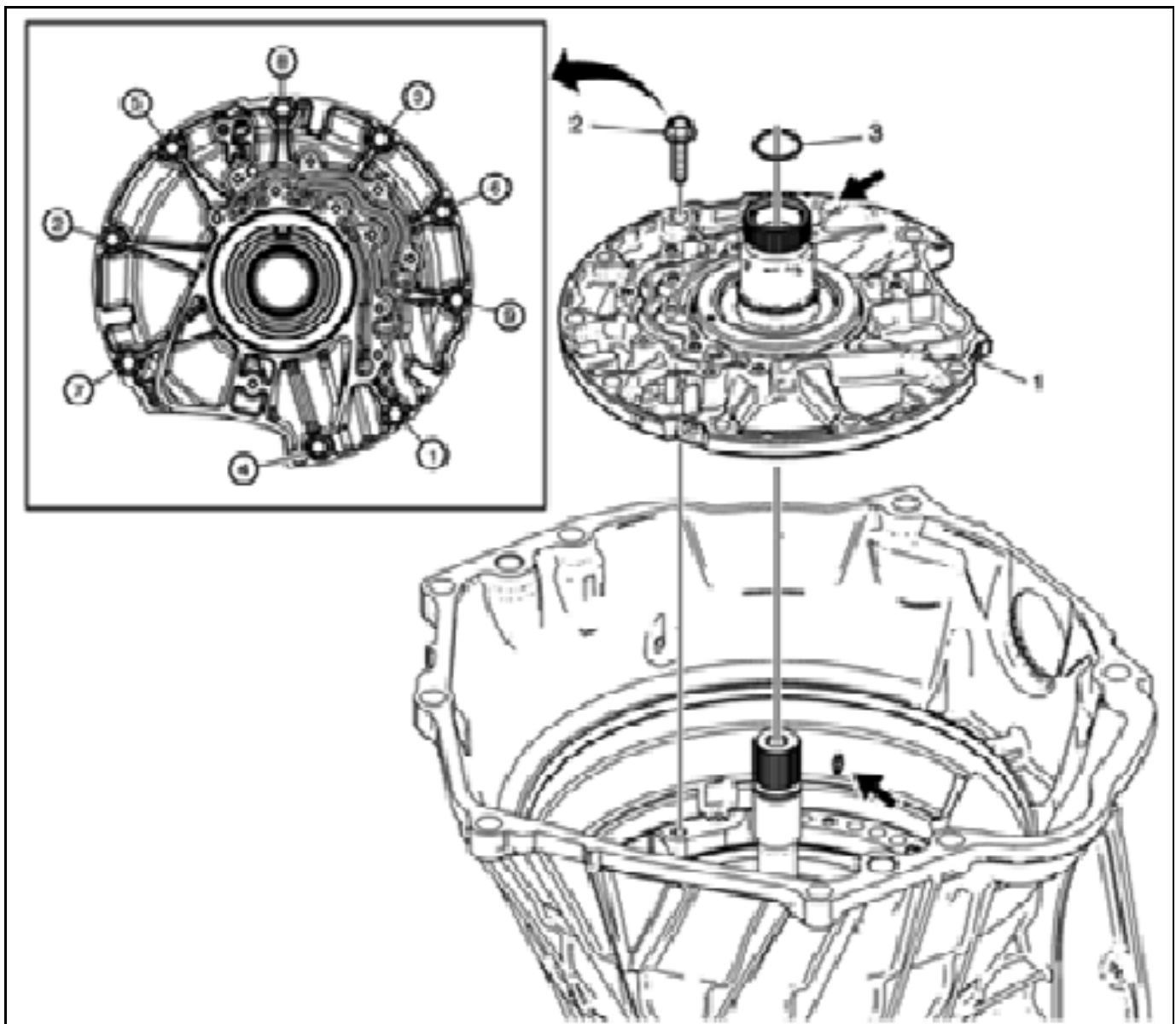

4358780

Note: Align the bolt hole indicated by the arrow with the arrow that is cast into the case and push down to seat.

17. Install the NEW stator shaft support assembly (1).
18. Install the nine stator shaft support bolts (2). Tighten the bolts in the sequence shown. Tighten the bolts to **31 N•m (23 lb ft)**.
19. Install a NEW turbine shaft O-ring seal (3).

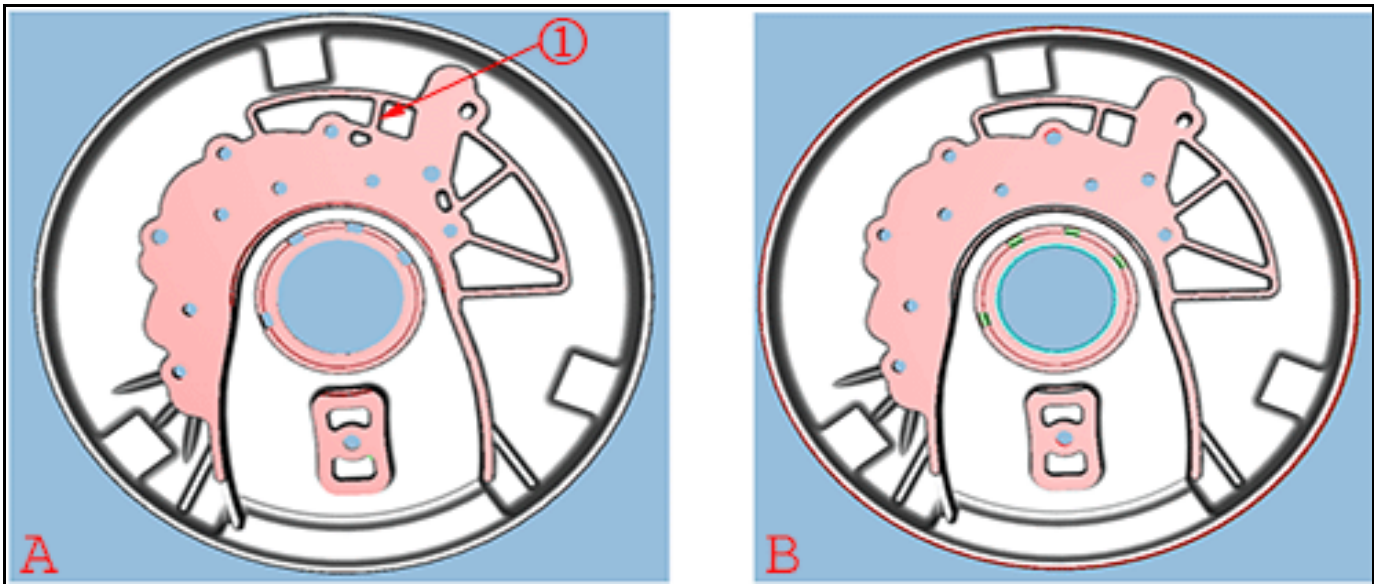

4358782

Legend

(A) Old cover - 8L90 Only

(B) New cover - 8L90 Only

Note: The casting void has been eliminated from the underside of the cover for the 8L90 only (see illustration). The 8L45 is not required.

- 20. Using the *DT-43772* Torque Converter Seal Installer, install a NEW torque converter fluid seal (1) on the front cover.

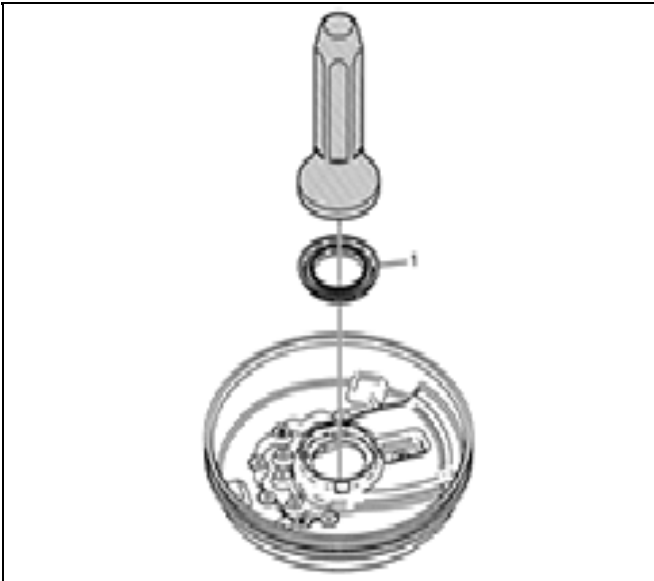

4358784

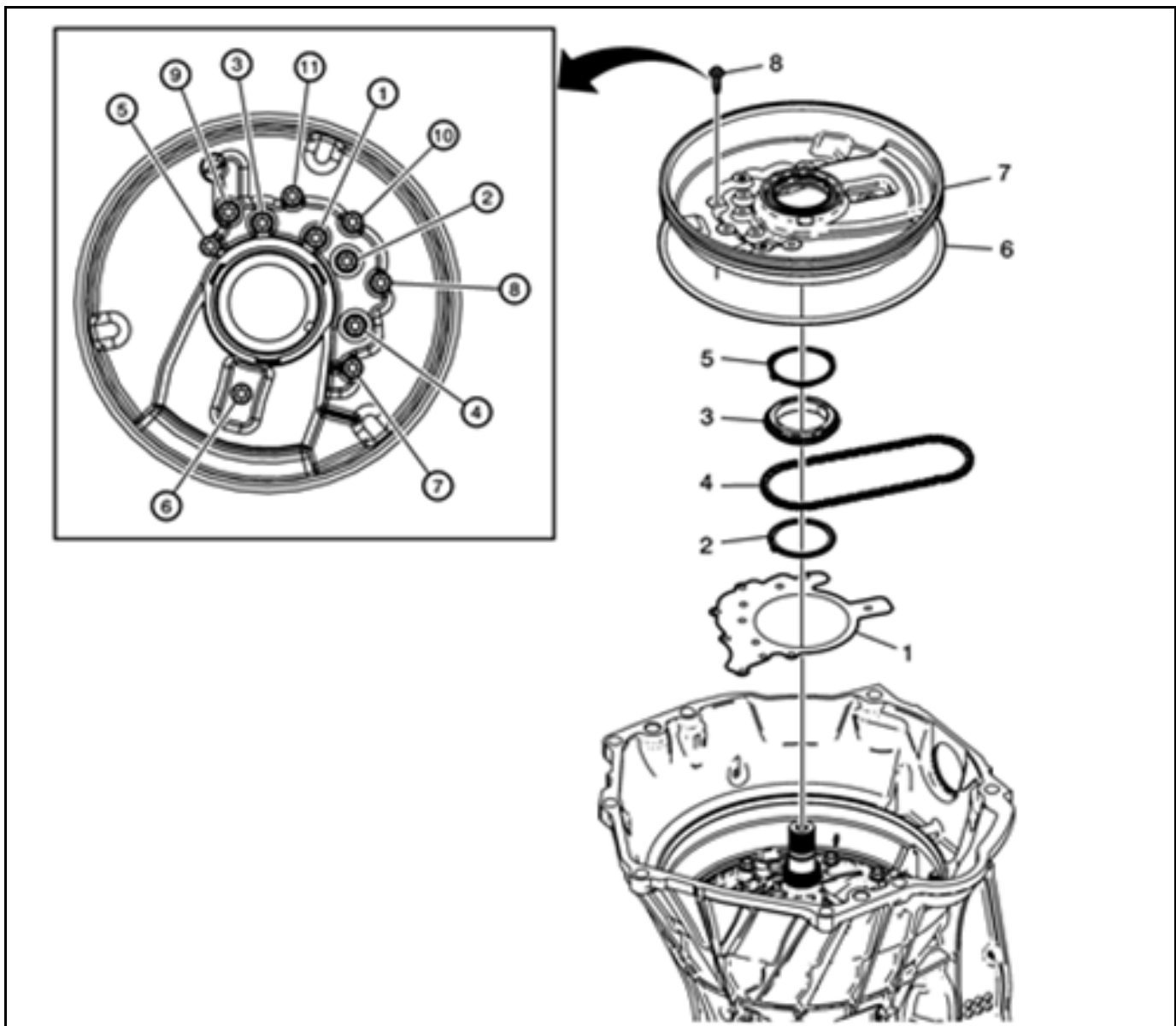

4358787

21. Install a NEW front support cover gasket (1).
22. Install the (rear) drive sprocket thrust washer (2) on the stator shaft support assembly.
23. Install the drive sprocket (3) and drive link assembly (4).
24. Install the (front) support cover gasket (5) on the front cover (7).
25. Install the front cover seal (6) on the front cover (7).

Note: Ensure the drive link assembly is not pinched by the front cover and moves freely on the drive sprocket.

26. Install the front cover (7) on the 8L90 only.
27. Install the 11 NEW front cover bolts (8). Gradually tighten the bolts in the sequence shown. Tighten the bolts a first pass to **6.5 N•m (58 lb in)**. Tighten the bolts a final pass **30 Degrees**.

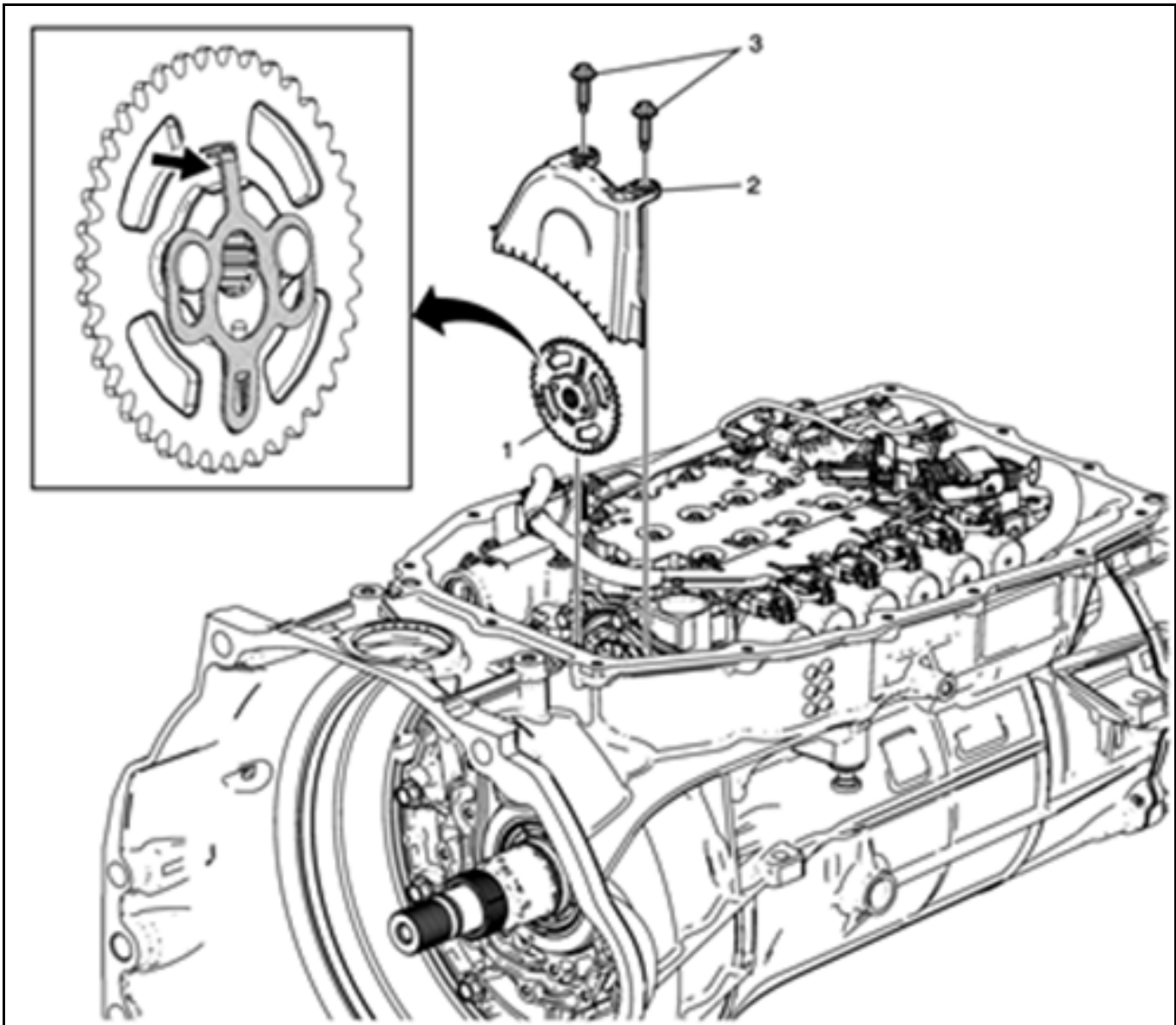

4358789

Note: Ensure the driven sprocket locking tab is in the unlocked position before installing the sprocket. The driven sprocket locking tab is located on the back of the sprocket and faces the pump.

28. Install the drive link (chain) to the driven sprocket (1) and then install the driven sprocket to the oil pump shaft. Rotate the sprocket as shown and push down on the tab until it locks the driven sprocket in place.
29. Install the fluid baffle (2).
30. Using the DT-48285 Torx Plus socket, secure the baffle using two NEW fluid baffle bolts (3). Tighten the bolts a first pass to **4 N•m (35 lb in)**. Tighten the bolts a final pass to **45 degrees**.

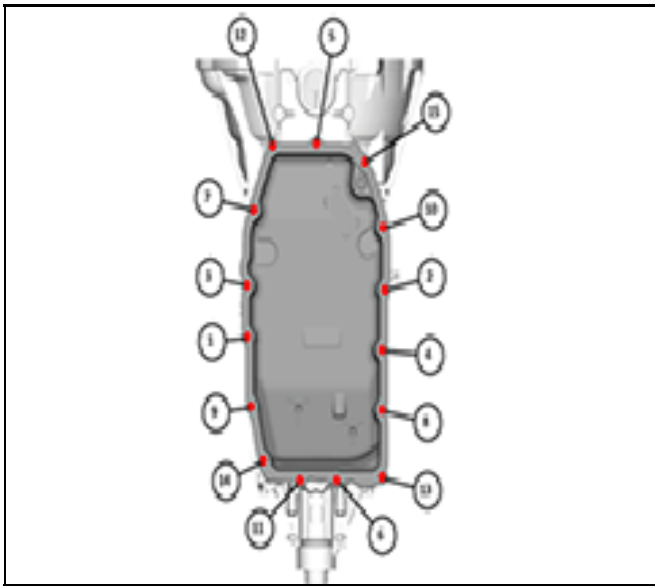

4358796

31. Install the fluid pan and gasket and secure with 15 bolts. Tighten the bolts to **10 N•m (89 lb in)** in the sequence shown.
32. Install the transmission into the vehicle. Refer to *Transmission Replacement* in SI.

Parts Information

Description	Part Number	Qty	Trans Model	Component Number in Disassembled Views
GASKET-A/TRNS FLUID PAN	24260071	1 (if required)	8L45/8L90	48
BOLT/SCREW-A/TRNS FLUID BFL	11548404	2	8L45/8L90	12
BOLT/SCREW-A/TRNS CASE FRT CVR	11548201	11	8L45/8L90	3
SEAL-A/TRNS CASE FRT CVR	24266366	1 (if required)	8L90	5
SEAL-A/TRNS CASE FRT CVR	24251906	1 (if required)	8L45	5
GASKET-A/TRNS FRT SUPT CVR	24272658	1	8L90	19
GASKET-A/TRNS FRT SUPT CVR	24272883	1	8L45	19
WASHER-DRV SPKT THR (FRONT)	24259119	1 (if required)	8L45/8L90	6
WASHER-DRV SPKT THR (REAR)	24259427	1 (if required)	8L45/8L90	8
SEAL-TURB SHF (O RING)	24261849 (Part of 24271697 kit)	1	8L90	500
SEAL-TURB SHF (O RING)	24261848 (Part of 24277071 kit)	1	8L45	500
SUPPORT ASM-STATOR SHF	24277234	1	8L90	14
SUPPORT ASM-STATOR SHF	24277230	1	8L45	14

Description	Part Number	Qty	Trans Model	Component Number in Disassembled Views
COVER-A/TRNS CASE FRT	24277964	1 (if required)	8L90	4
SEAL-T/CV FLUID	24259216	1	8L45/8L90	18
RING-1-3-5-6-7 CLU FLUID SEAL	24266593	2	8L90	15
RING-1-3-5-6-7 CLU FLUID SEAL	24266594	2	8L45	15
SEAL ASM-T/CV FLUID	24266709	1	8L45/8L90	2
FLUID, A/TRANS (DEXRON HP ATF) (1 QUART)	19300536-US 19300537-CA	As Required	8L45/8L90	

Warranty Information

Labor Operation	Description	Labor Time
8465020	Stator Shaft Support Replacement	Use Published Labor Operation Time

Version	3
Modified	April 22, 2016 – Removed stator part numbers from procedure. New part number for Trans Frt Gasket. June 16, 2016 – Clarifying Condition, added Cause statement and added diagnostic procedures for C5 clutch and Torque Converter above Correction.

GM bulletins are intended for use by professional technicians, NOT a "do-it-yourselfer". They are written to inform these technicians of conditions that may occur on some vehicles, or to provide information that could assist in the proper service of a vehicle. Properly trained technicians have the equipment, tools, safety instructions, and know-how to do a job properly and safely. If a condition is described, DO NOT assume that the bulletin applies to your vehicle, or that your vehicle will have that condition. See your GM dealer for information on whether your vehicle may benefit from the information.



WE SUPPORT VOLUNTARY
TECHNICIAN
CERTIFICATION