

TECHNICAL BULLETIN

Q631NAS1

13 OCT 2016



© Jaguar Land Rover North America, LLC

NOTE: The information in Technical Bulletins is intended for use by trained, professional Technicians with the knowledge, tools, and equipment required to do the job properly and safely. It informs these Technicians of conditions that may occur on some vehicles, or provides information that could assist in proper vehicle service. The procedures should not be performed by 'do-it-yourselfers'. If you are not a Retailer, do not assume that a condition described affects your vehicle. Contact an authorized Land Rover service facility to determine whether this bulletin applies to a specific vehicle.

SECTION: 501-10

Service Action: 2nd Row Seat Runners Creak

AFFECTED VEHICLE RANGE:

Discovery Sport (LC)

Model Year: 2016-2017

VIN: 544578-646315

Assembly Plant: Halewood

MARKETS:

NAS

CONDITION SUMMARY:

Situation: An issue has been identified on a limited number of vehicles within the listed Affected Vehicle Range where a 'creak' noise may be evident due to contact between the inner and outer track on the inboard side of the second row seat frame.

Action: Retailers are required to **HOLD** affected new vehicles that are within your control and refrain from releasing the vehicles for **new vehicle sale** pending completion of the Service Instruction detailed in this Technical Bulletin. Unsold vehicles should have this performed as part of the Pre-Delivery Inspection (PDI) process but **must** have it completed prior to vehicle handover to the customer.

Affected vehicles already in the hands of customers should be updated at the next available opportunity.

PARTS:



NOTE: Order only the expected percentage demand of parts identified.

DESCRIPTION	PART No./SUNDRY CODE	QTY./VALUE	EXPECTED % of VEHICLES REQUIRING PARTS
*NyoGel® 774	ZZZ001	**\$7.11 (CAD); \$5.43 (USD)	100

** - an allowance has been provided to cover the cost of the NyoGel® 774 and must be claimed using Sundry Code 'ZZZ001'.

SPECIAL TOOLS:

Refer to Workshop Manual/Service Instruction for any required special tools

WARRANTY:



NOTE: Check DDW to ensure that a vehicle is affected by this program prior to undertaking any rework action.

At the time of confirming a booking for vehicle repair, ensure that **all** outstanding Recalls and Service Actions are identified to ensure the correct parts are available and adequate workshop time is allocated for repairs to be completed at one visit.

Warranty claims must be submitted quoting Program Code **Q631** together with the relevant Option Code from the table. SRO and parts information is included for information only. The Option Code(s) that allows for the drive in / drive

out allowance can only be claimed if the vehicle is brought back into the workshop for this action alone to be undertaken.

This program is valid for a limited time only. Warranty claims with a repair date prior to the **31 October 2018** closure date must be submitted or payment within 30 calendar days of completion of the repair.

Repair procedures are under constant review and therefore times / prices are subject to change; those quoted here must be taken as guidance only. Refer to TOPIX to obtain the latest repair time.

PROGRAM CODE	OPTION CODE	DESCRIPTION	SRO	TIME (HOURS)	PARTS/SUNDRY CODE	QTY./VALUE*
Q631	B	Apply grease to upper and lower section of seat track	78.85.89.67	0.50	ZZZ001	\$7.11 (CAD); \$5.43 (USD)
Q631	C	Apply grease to upper and lower section of seat track Drive in / drive out	78.85.89.67 02.02.02	0.50 0.20	ZZZ001	\$7.11 (CAD); \$5.43 (USD)

* - an allowance has been provided to cover the cost of the NyoGel® 774 and must be claimed using Sundry Code 'ZZZ001'.

Normal Warranty policies and procedures apply.

COMPONENT LOCATION:

1. Second row seating seat track component location.

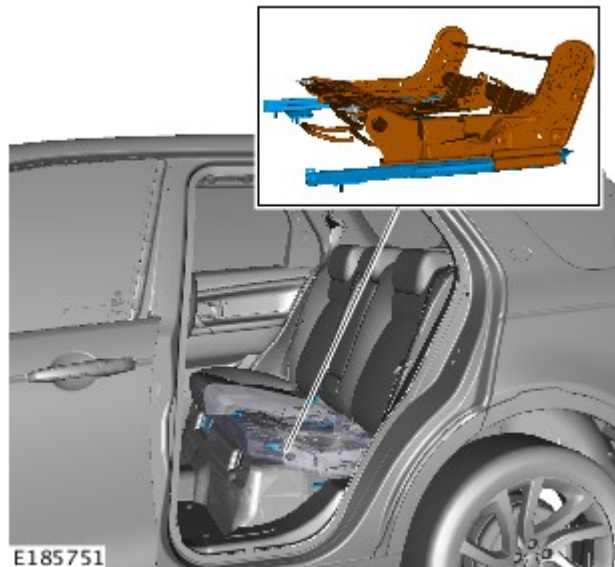

SERVICE INSTRUCTION:



CAUTION: Care must be taken not to damage or dirty the seats.

1. Remove the second row left-side seat (see TOPIX Workshop Manual section 501-10: Seating).
2. Place the frame on a bench and turn the seat on its side.
3. Pull the lever up and slide both seat tracks into the fully rearwards position.

4. Apply NyoGel® 774 (or equivalent Polyalphaolefin based, silica thickened, synthetic hydrocarbon grease, with a viscosity index of 274) to a new cable tie.

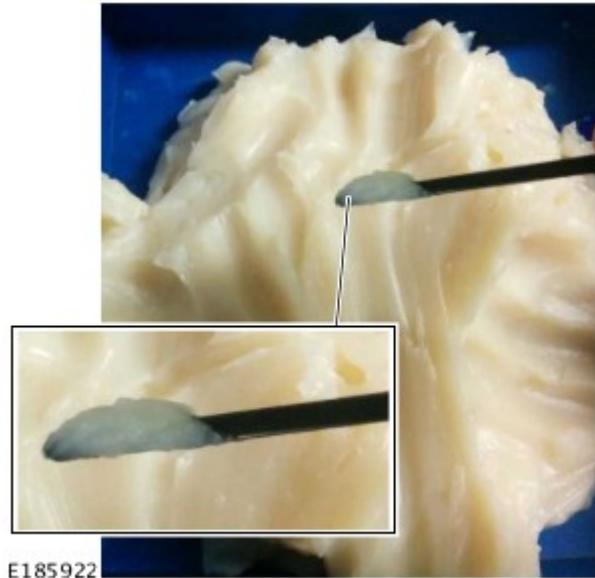

5. Push the NyoGel® 774 (or equivalent Polyalphaolefin based, silica thickened, synthetic hydrocarbon grease, with a viscosity index of 274) into both runners with a new cable tie.



6. Apply NyoGel® 774 (or equivalent Polyalphaolefin based, silica thickened, synthetic hydrocarbon grease, with a viscosity index of 274) to the left side runner ().

- Do not leave the runner dry ().
- Do not apply too much grease to the runner ().



7. Apply NyoGel® 774 (or equivalent Polyalphaolefin based, silica thickened, synthetic hydrocarbon grease, with a viscosity index of 274) to the right side runner ().

- Do not leave the runner dry ().
- Do not apply too much grease to the runner ().



8. Pull the lever up and operate the seat tracks a minimum of five times to lubricate the seat tracks.

9. Make sure that both seat tracks are returned to the original fully forward position.

10. Install the second row left-side seat (see TOPIX Workshop Manual section 501-10: Seating).