

# Hybrid System Electrical Safety Precautions

**Service Category** General

**Section** Pre-Delivery Service

**Market** USA

Lexus Supports  
ASE Certification 

## Applicability

YEAR(S)	MODEL(S)	ADDITIONAL INFORMATION
2016	GS450H	

## Introduction

This bulletin provides general high-voltage safety precautions for the hybrid system. The hybrid system circuits operate with up to 650 volts. These high voltages are dangerous and can cause severe personal injuries, burns, and electrical shock if proper safety precautions are NOT followed. Be sure to carefully review all applicable Repair Manual procedures BEFORE performing service.

As a policy, and to ensure safety, no Lexus dealership technician is qualified to service or repair hybrid vehicles until Lexus course L071 has been successfully completed.

### **CAUTION**

**When servicing the high-voltage system on the 2016 GS 450H, wait AT LEAST 10 minutes after disconnecting the service plug BEFORE touching any of the high-voltage connectors or terminals.**

# Hybrid System Electrical Safety Precautions

## Introduction (Continued)

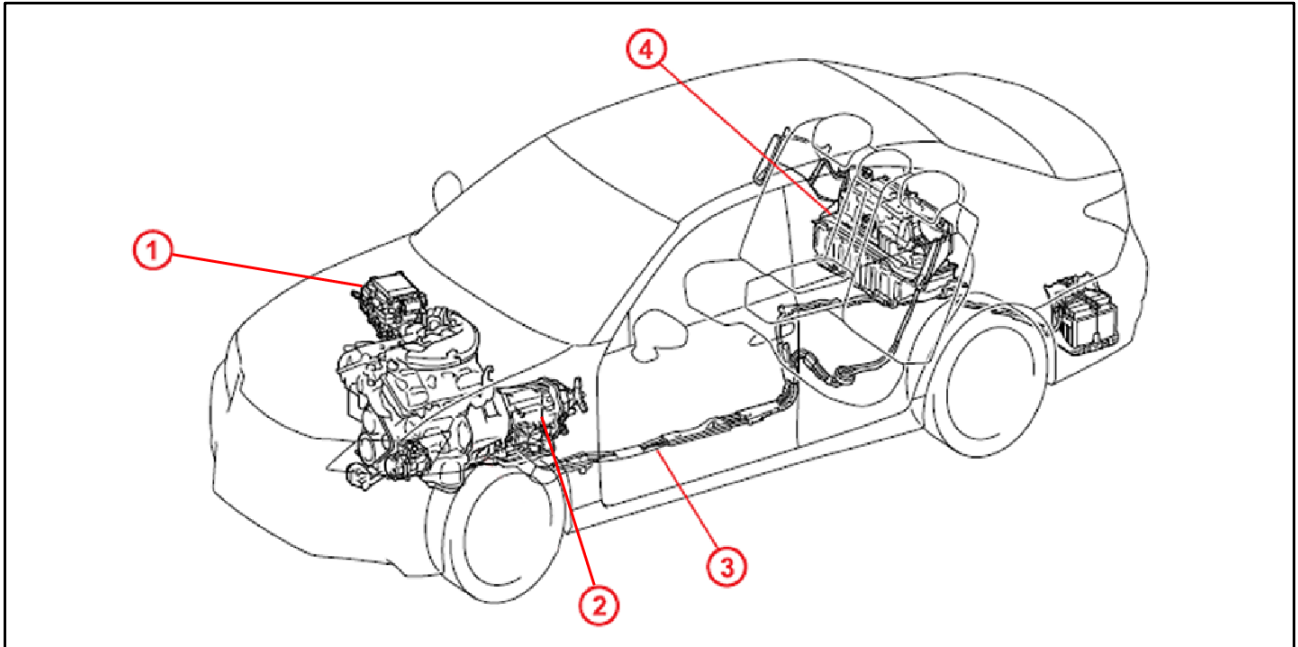

<b>1</b>	<b>Inverter Assembly: Boost Converter, Inverter, MG ECU</b>
<b>2</b>	<b>Hybrid Transmission: MG1, MG2</b>

<b>3</b>	<b>Power Cable</b>
<b>4</b>	<b>HV Battery Module: DC/DC Converter, Battery Smart Unit, SMR</b>

## Warranty Information

OP CODE	DESCRIPTION	TIME	OPF	T1	T2
N/A	Not Applicable to Warranty	-	-	-	-

## Required Tools & Equipment

SPECIAL SERVICE TOOLS (SST)	PART NUMBER	QTY
Electrical Insulating Gloves	<a href="#">00002-03100-S (Small)</a> <a href="#">00002-03200-M (Medium)</a> <a href="#">00002-03300-L (Large)</a>	1

\* Essential SST.

**NOTE**  
 Additional SSTs may be ordered by calling 1-800-933-8335.

**CAUTION**  
 Always inspect Electrical Insulation Gloves before use for cracks, ruptures, tears, pinholes, or damage. Do NOT wear if damaged.

## Hybrid System Electrical Safety Precautions

### Electrical Safety Precautions

#### **CAUTION**

#### **HYBRID HIGH-VOLTAGE SAFETY NOTICE**

A Lexus gas/electric hybrid vehicle has high-voltage DC and AC systems. Both DC and AC high-voltage are very dangerous and can cause personal injury, severe burns, electric shock, and even fatal injury.

#### ***Regular Service and Repairs (Pre-Delivery Service [PDS], and Non-High-Voltage Maintenance and Service)***

Ensure that all persons performing PDS or non-high-voltage maintenance and service:

1. Follow all Caution labels attached to high-voltage parts.
2. Do NOT touch or attempt to remove or replace any high-voltage (orange-colored) wiring and connectors.
3. Do NOT touch the orange service plug.
4. Read, understand, and follow the safety procedures in the Pre-Delivery Service Manual, Repair Manual, and all applicable Technical Service Information Bulletins for the vehicle.

#### ***High-Voltage Repairs***

Ensure that all technicians performing repairs to high-voltage systems:

1. Complete the hybrid training course L071 provided at the Lexus Area office.
2. Read, understand, and follow the safety procedures in the Repair Manual and all applicable Technical Service Information Bulletins for the vehicle.
3. Use high-voltage gloves and safety glasses whenever servicing high-voltage systems.
4. After disconnecting the service plug, wait AT LEAST 10 minutes BEFORE touching any of the high-voltage connectors or terminals.
5. Are responsible for managing the safety of any hybrid vehicle or parts they are working on.
6. Maintain a "safety zone" around their work, including using yellow caution tape and "DO NOT TOUCH — HIGH-VOLTAGE" signs when high-voltage system repairs are to be left unattended.

## Hybrid System Electrical Safety Precautions

---

### Electrical Safety Precautions (Continued)

**CAUTION****HYBRID HIGH-VOLTAGE SAFETY NOTICE (Continued)***In the Event the Hybrid Vehicle is Involved in an Accident*

1. Do NOT touch any high-voltage wiring, connectors, or parts, such as the inverter or the hybrid battery assembly.
2. Do NOT touch the potassium hydroxide electrolyte that might spill or leak from the hybrid battery as the result of an accident. If potassium hydroxide electrolyte gets on your skin or in your eyes, neutralize it IMMEDIATELY with a saturated boric acid solution (ratio: 80 grams boric acid to 2 liters water or alternatively, flush repeatedly with large amounts of water).

**SEEK IMMEDIATE MEDICAL ATTENTION.**

3. If a vehicle fire occurs, water has been proven to be a suitable extinguishing agent.
4. See the Emergency Response Guide on the Lexus Technical Information System (TIS) or Dealer Daily for more information.

If you have any questions, contact your District Service and Parts Manager.

For additional Caution notices, download the PDF files from Dealer Daily, Lexus Customer Services website, Forms, and print on a color printer.