

TECHNICAL BULLETIN
JTB00499NAS3
12 OCT 2016



© Jaguar Land Rover North America, LLC

NOTE: The information in Technical Bulletins is intended for use by trained, professional Technicians with the knowledge, tools, and equipment required to do the job properly and safely. It informs these Technicians of conditions that may occur on some vehicles, or provides information that could assist in proper vehicle service. The procedures should not be performed by 'do-it-yourselfers'. If you are not a Retailer, do not assume that a condition described affects your vehicle. Contact an authorized Jaguar service facility to determine whether this bulletin applies to a specific vehicle.

This reissue replaces all previous versions. Please destroy all previous versions.

Changes are highlighted in gray

SECTION: 204-02

'Creak' Noise From Rear Suspension

AFFECTED VEHICLE RANGE:

F-PACE (X761)

Model Year: 2017
VIN: 045409-075852
Assembly Plant: Solihull

MARKETS:

NAS

CONDITION SUMMARY:

Situation: A 'creak' noise may be evident from the rear of the vehicle while driving.

Cause: This may be caused by deflection of the rear spring top mount isolator, allowing the spring to contact the vehicle body.

Action: Should a customer express this concern, see the Service Instruction outlined below.

PARTS:



NOTE: An allowance (\$10.00 [CAD], \$7.50 [USD]) has been allocated to cover the cost of the locally sourced etch primer and must be claimed using ZZZ001.

C2Z2224	Wishbone nut	2
T2H2202	Damper bottom bolt	2
T2H3176	Lower wishbone nut	2
T2H3507	Damper bottom nut	2
T2H3774	Lower wishbone bolt	2
T2H16285	Wishbone bolt	2
T4A1994	Lower Isolator	2
T4A2003	Upper Isolator	2
XR848057	ARB drop link nut	2
ZZZ001	*Etch primer	\$10.00 [CAD], \$7.50 [USD]

TOOLS:

Refer to Workshop Manual for any required special tools.

WARRANTY:

 **NOTE:** An allowance (\$10.00 [CAD], \$7.50 [USD]) has been allocated to cover the cost of the locally sourced etch primer and must be claimed using ZZZ001.

 **NOTE:** Repair procedures are under constant review, and therefore times are subject to change; those quoted here must be taken as guidance only. Always refer to TOPIx to obtain the latest repair time.

 **NOTE:** DDW requires the use of causal part numbers. Labor only claims must show the causal part number with a quantity of zero.

DESCRIPTION	SRO	TIME (HOURS)	CONDITION CODE	CAUSAL PART
Rear spring isolator - Set	64.20.02.99	0.7	GW2	T4A2008

 **NOTE:** Normal Warranty procedures apply.

NEW COMPONENT OVERVIEW

1. Lower and upper isolators.

- **A** = Lower Isolator - T4A1994.
- **B** = Upper Isolator - T4A2003.



E193708

SERVICE INSTRUCTION:

 **CAUTION:** Nuts and bolts must be tightened with vehicle at normal ride height.

1.  **CAUTION:** Make sure to support the vehicle with axle stands.

Remove the rear left wheel (see TOPIx Workshop Manual section 204-04: Wheels and Tires).

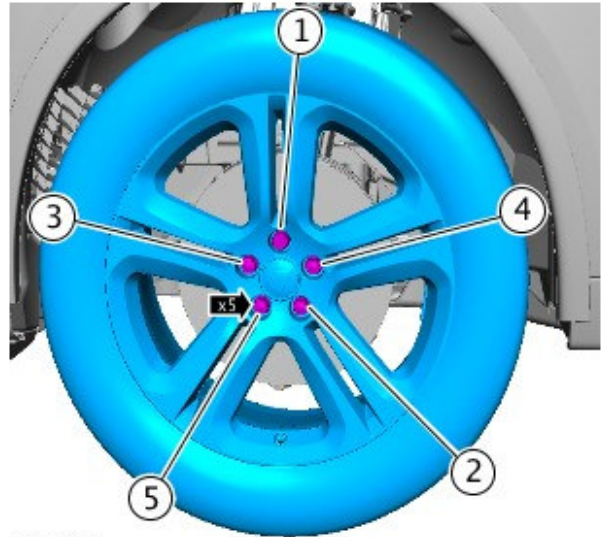

E192935

2. Install a suitable transmission jack and compress the rear left suspension.

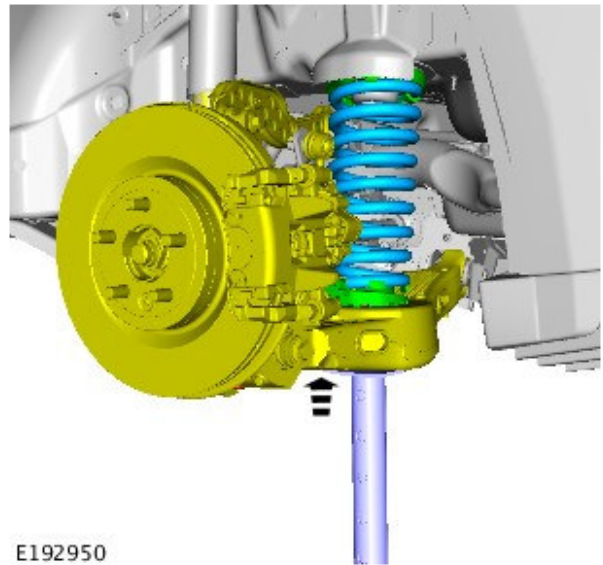

E192950

3. Install suitable coil spring compressors.

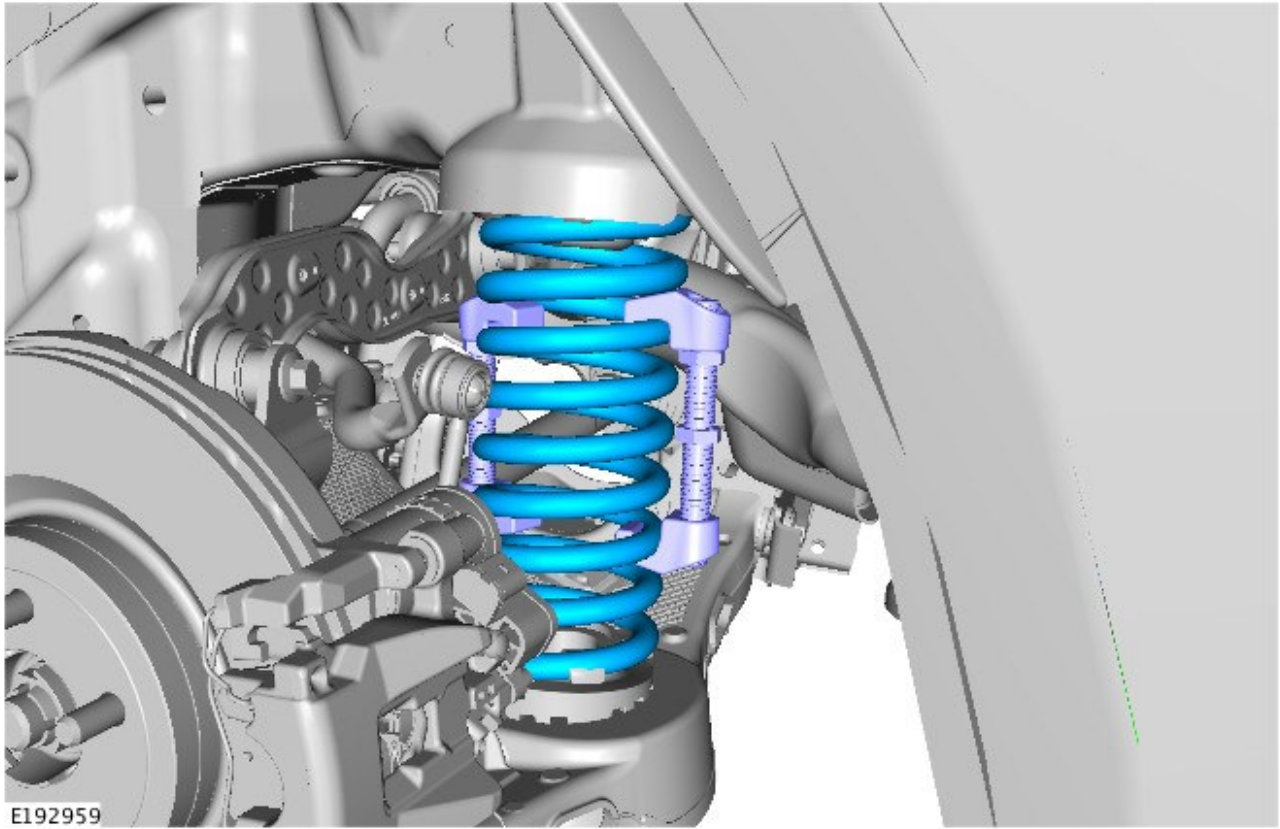

4. Remove and discard the stabilizer bar link nut.

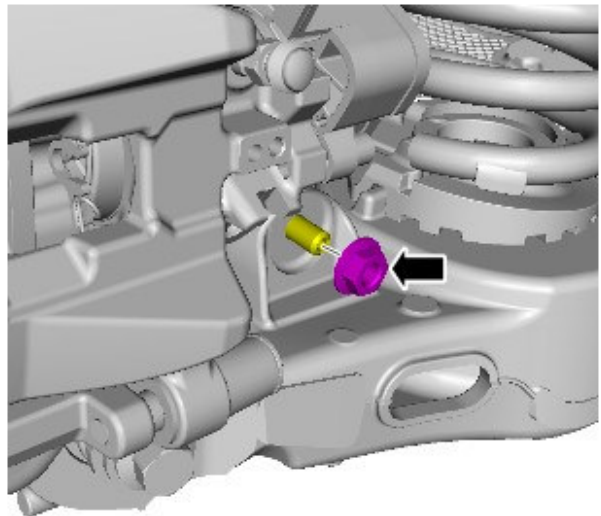

5. Remove and discard the rear shock absorber nut and bolt.

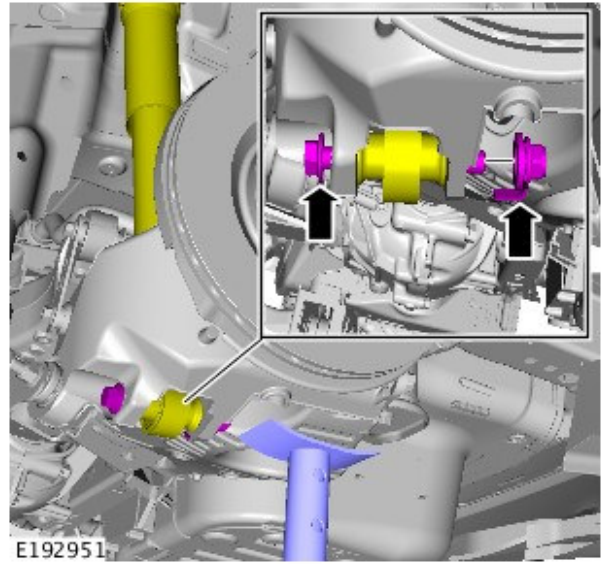

6. Remove and discard the rear tie-rod outer nut and bolt.

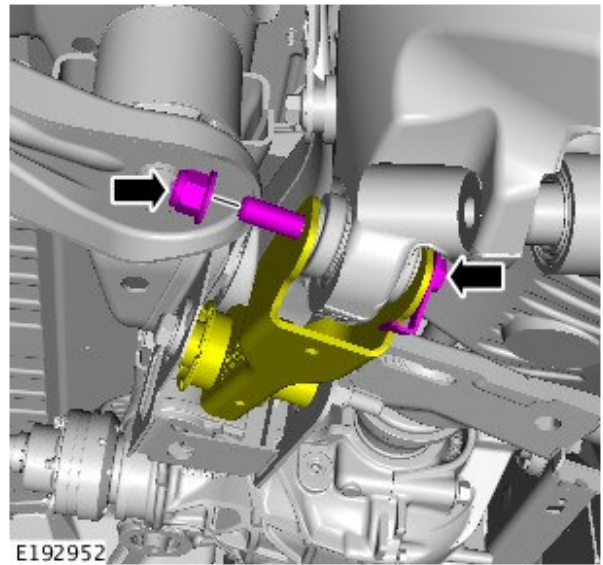

7. Remove and discard the rear lower arm nut and bolt.

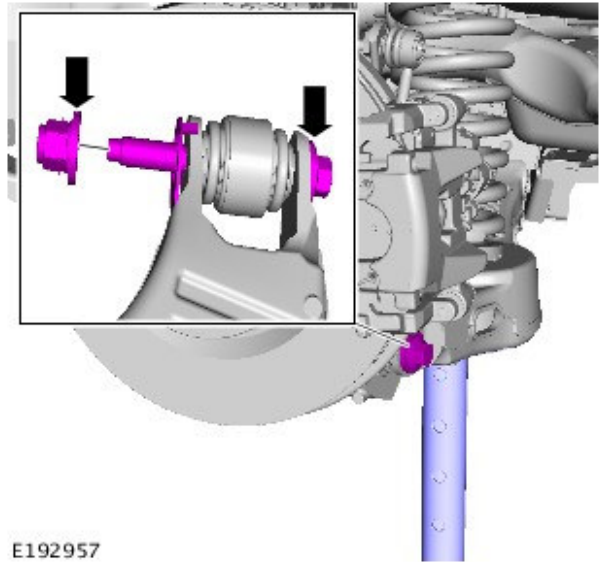

8. Note the orientation of the coil spring isolator on the rear lower arm.

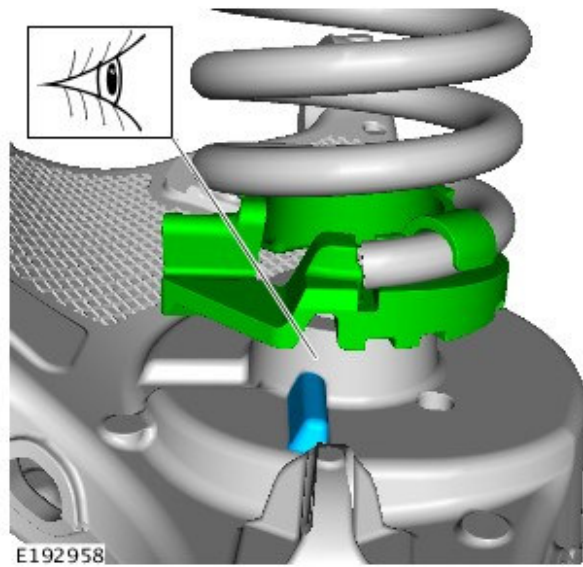

9. Lower the transmission jack to allow the rear lower arm to articulate **(1)** as shown and remove **(2)** the rear coil spring.

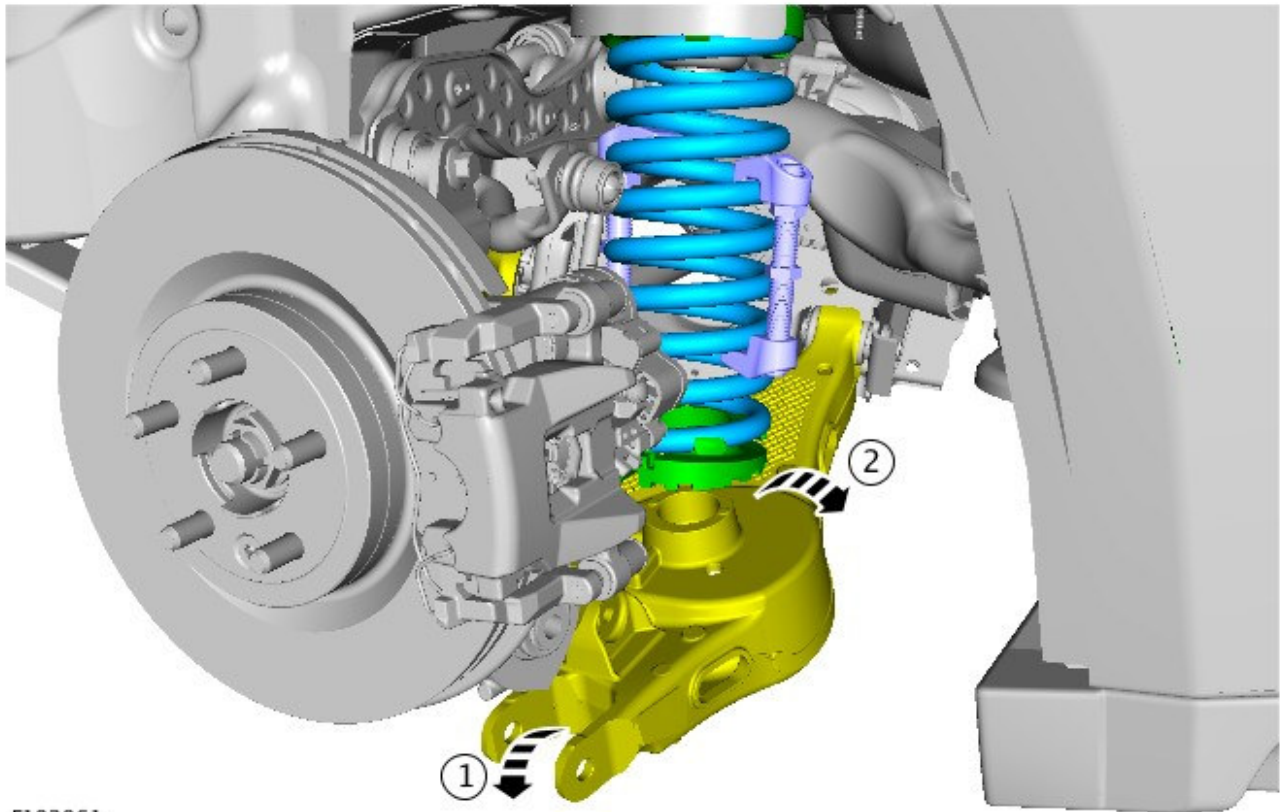

E192961

10. Apply etch primer to the upper mount in the area shown.

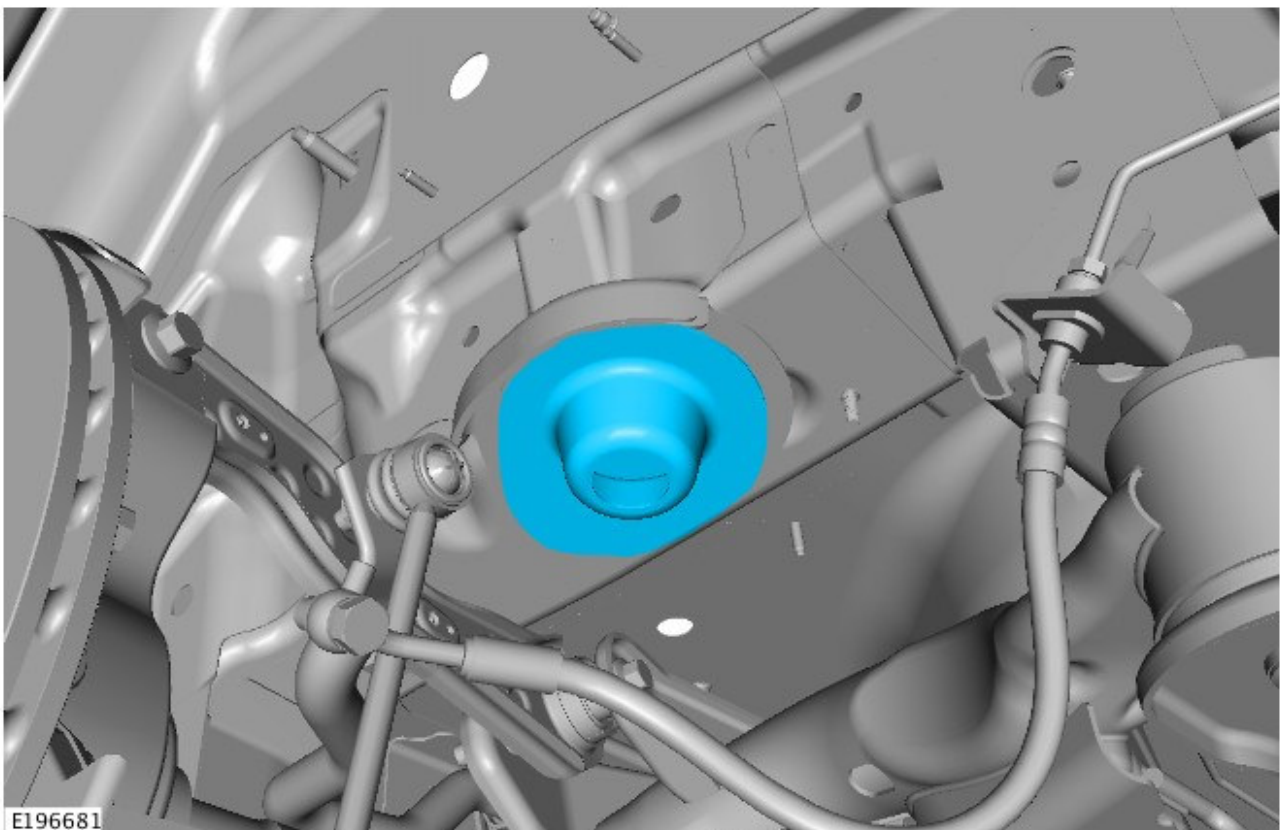

E196681

11. Apply etch primer to the upper mount in the area shown.

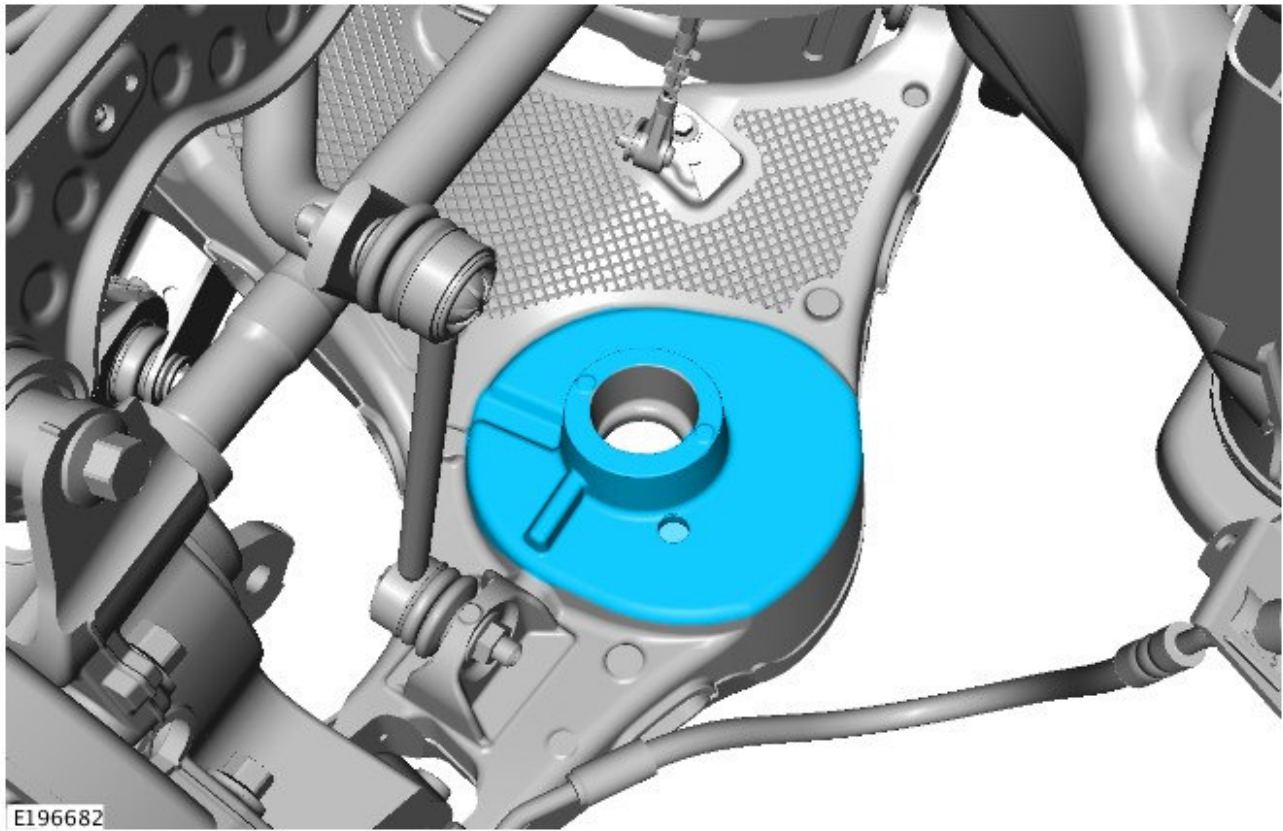

12. Remove and discard the upper and lower coil spring isolators.

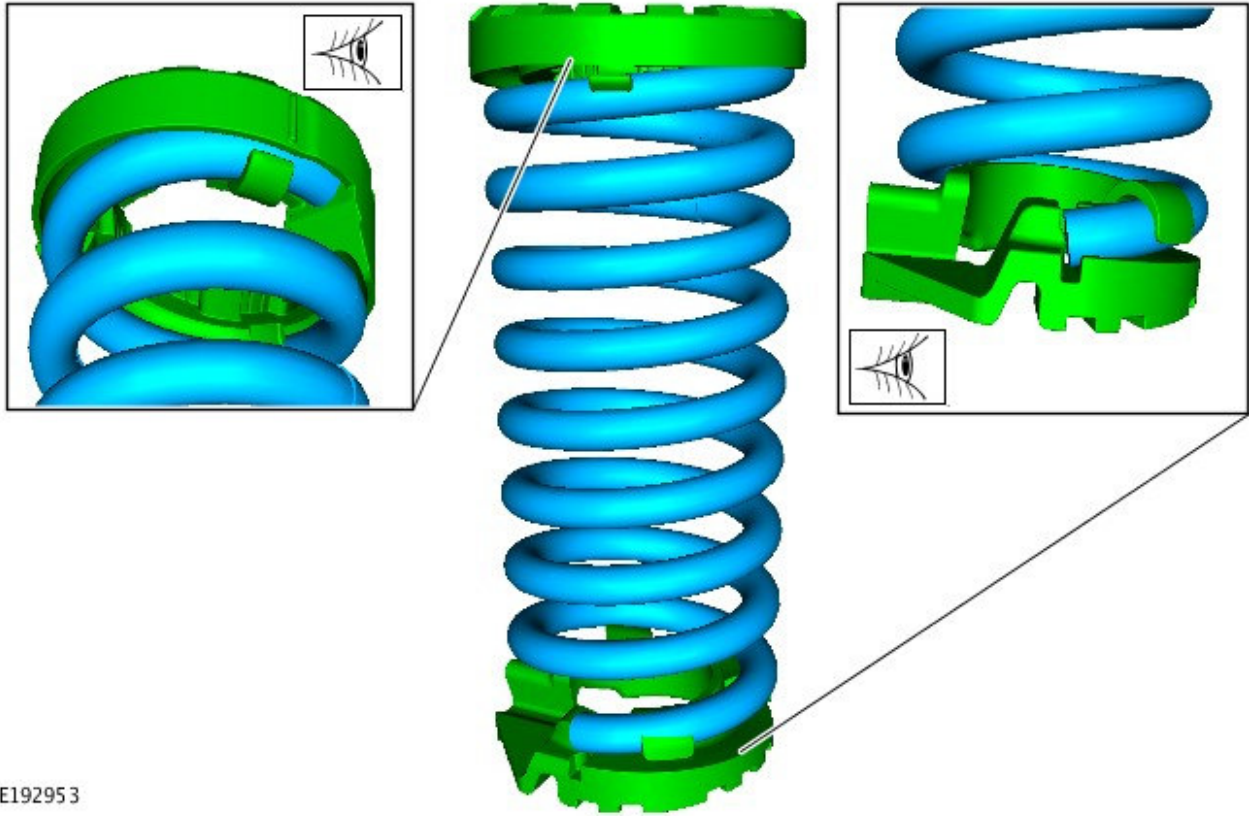

E192953

13.  **CAUTION: Make sure the upper and lower coil spring isolators are fitted in the correct orientation.**

Install the new upper and lower coil spring isolators.

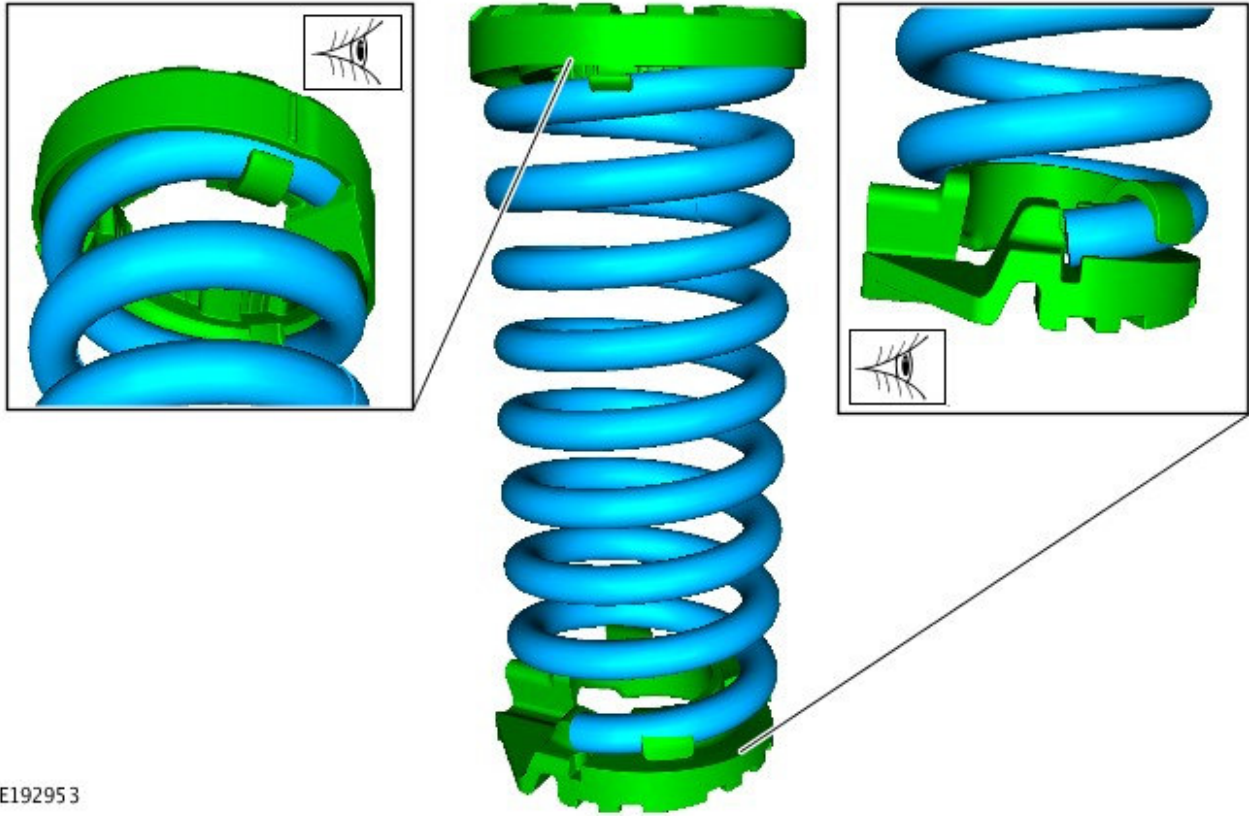

E192953

14.  WARNING: Make sure the rear coil spring is correctly located.

Install **(1)** the rear coil spring and use the transmission jack to support and raise **(2)** the rear lower arm.

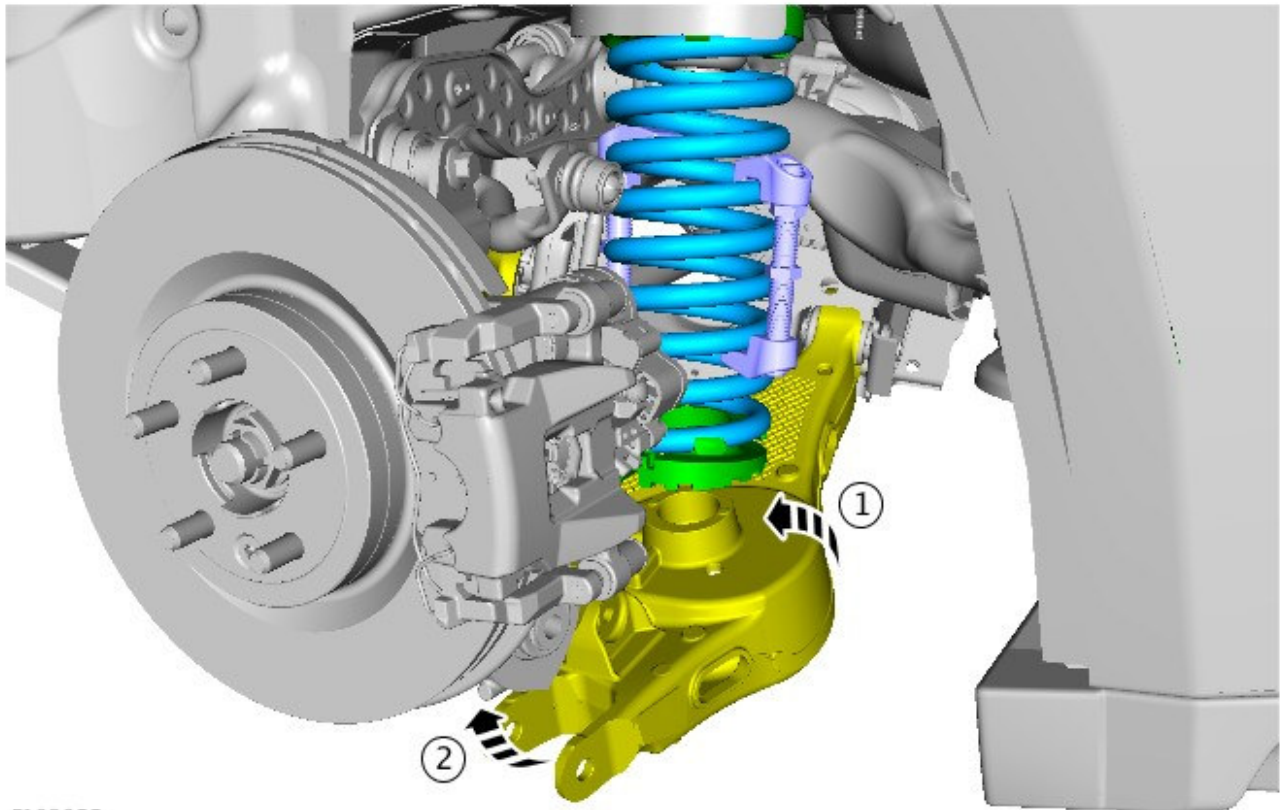

E192955

15.  WARNING: Make sure the rear coil spring is correctly located.

Make sure the lower rear coil spring isolator is engaged correctly on the rear lower arm.

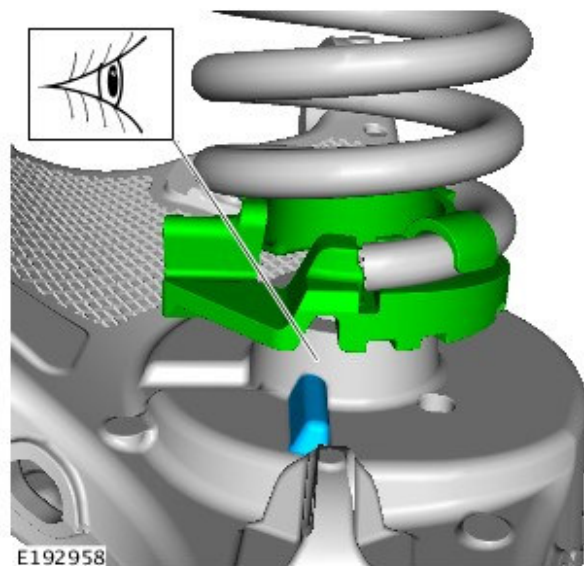

E192958

16. Install a new lower rear arm nut and bolt.

- Stage one - **Torque: 110 Nm**
- Stage two - **Torque: 60°**

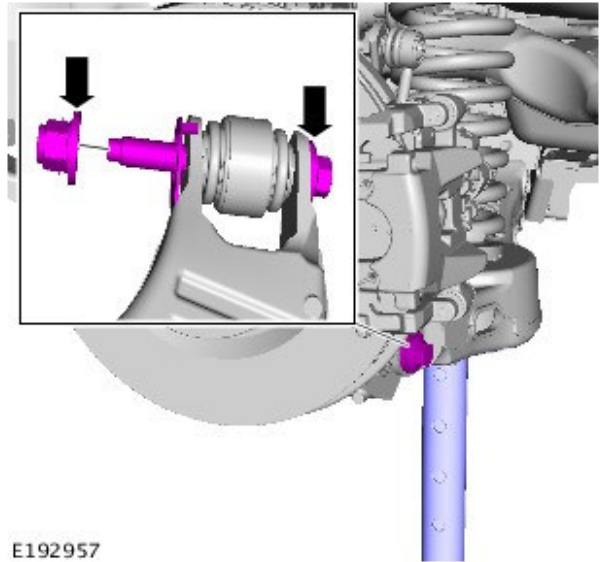

E192957

17. Install a new tie-rod nut and bolt.

- Stage one - **Torque: 60 Nm**
- Stage two - **Torque: 60°**

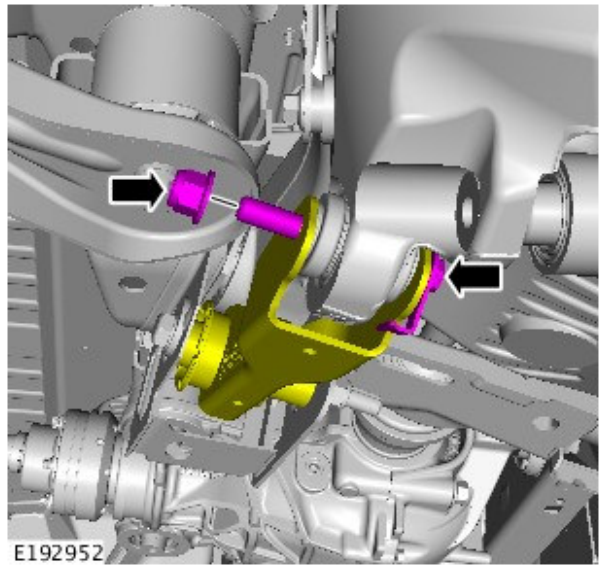

E192952

18. Install a new rear shock absorber nut and bolt.

- **Torque: 170 Nm**

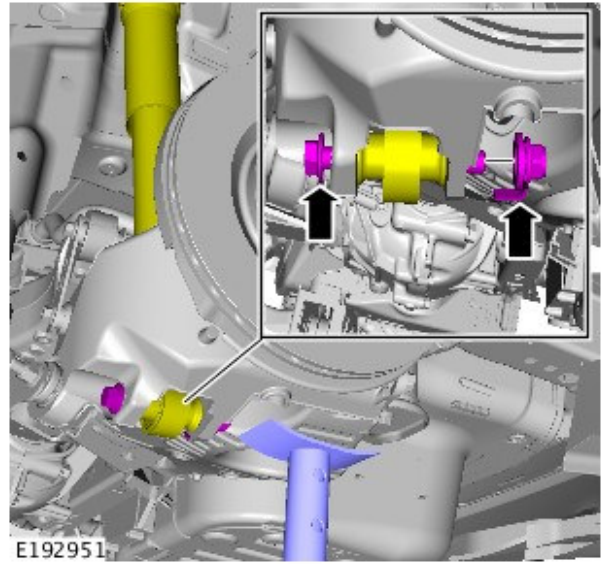

19. Install a new stabilizer bar link nut.

- Stage one - **Torque: 40 Nm**
- Stage two - **Torque: 45°**

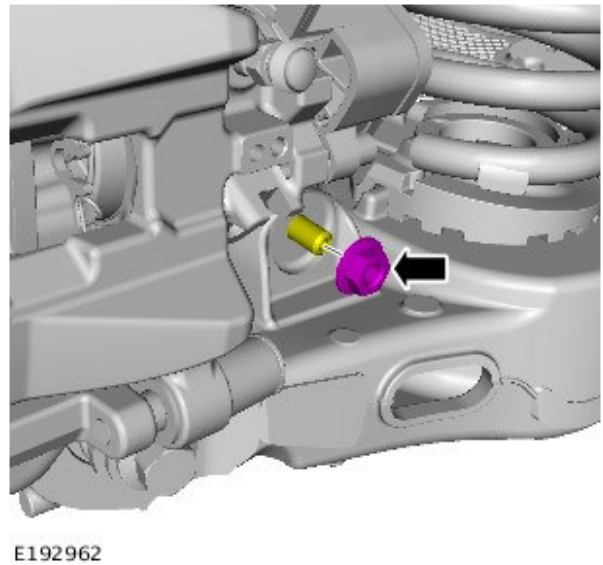

20. Using the transmission jack, raise the rear suspension.

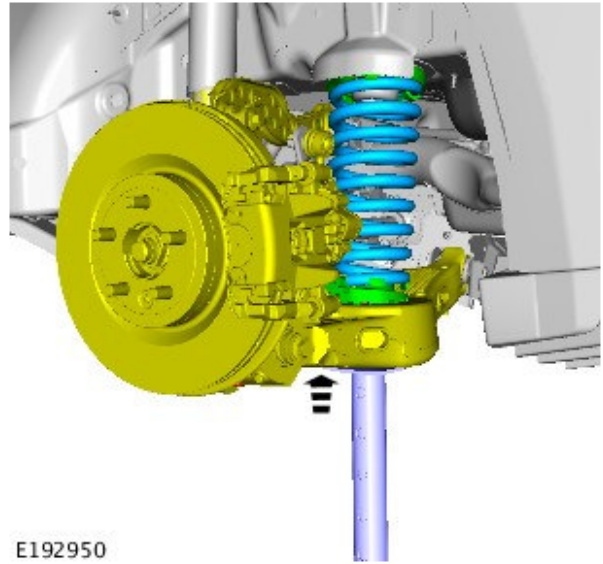

21. Remove the coil spring compressors.

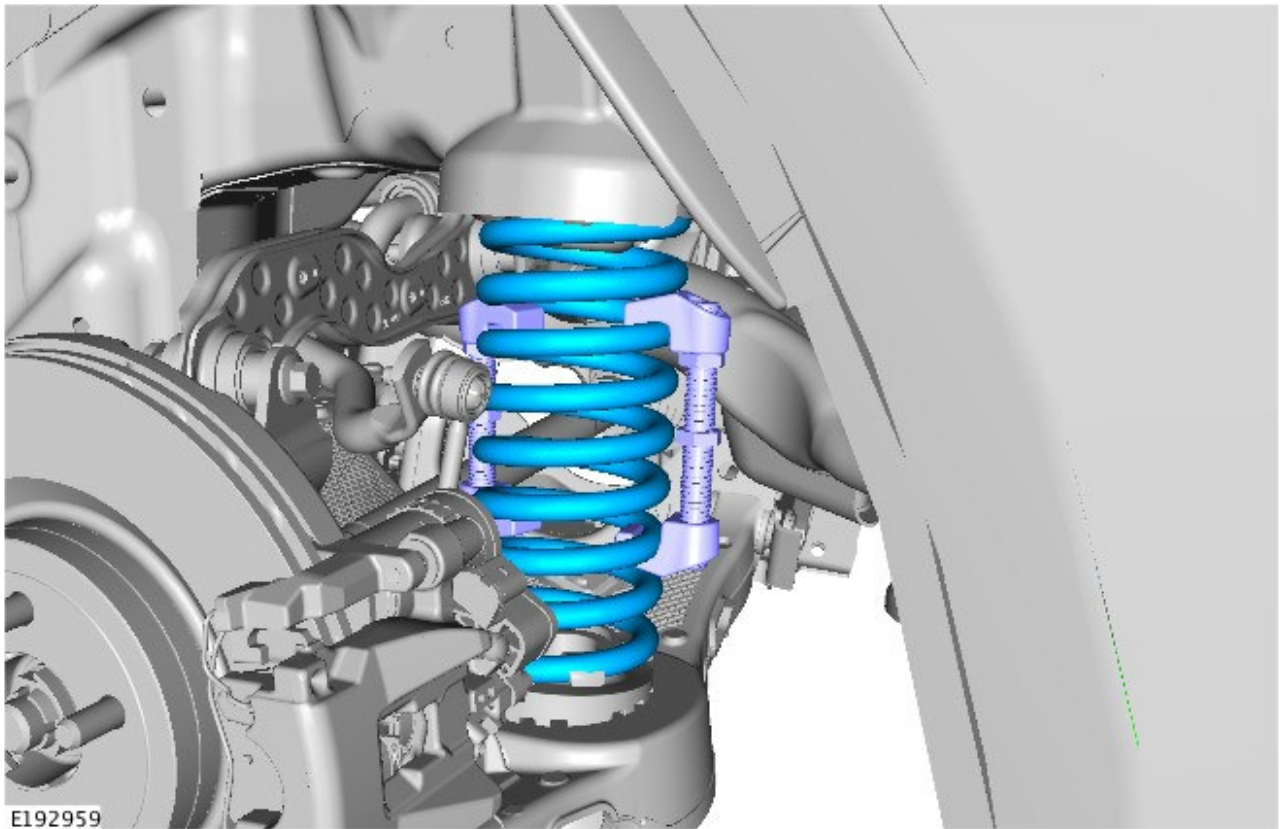

22. Lower and remove the transmission jack.

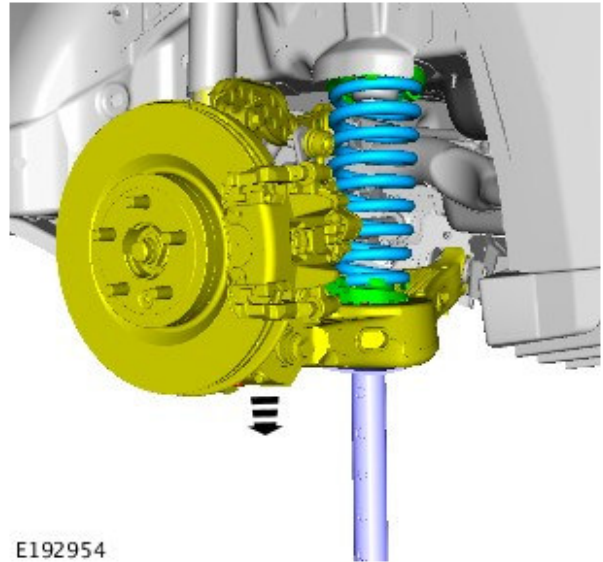

23.  **WARNING:** Apply a small amount of grease to the bore and spigot areas of the wheel before installation. Make sure the grease does not come into contact with the braking components and the wheel stud threads. Failure to follow these instructions may result in personal injury.

Install the rear left wheel (see TOPIX Workshop Manual section 204-04: Wheels and Tires).

- Stage one - **Torque: 4 Nm**
- Stage two - **Torque: 70 Nm**
- Stage three - **Torque: 133 Nm**

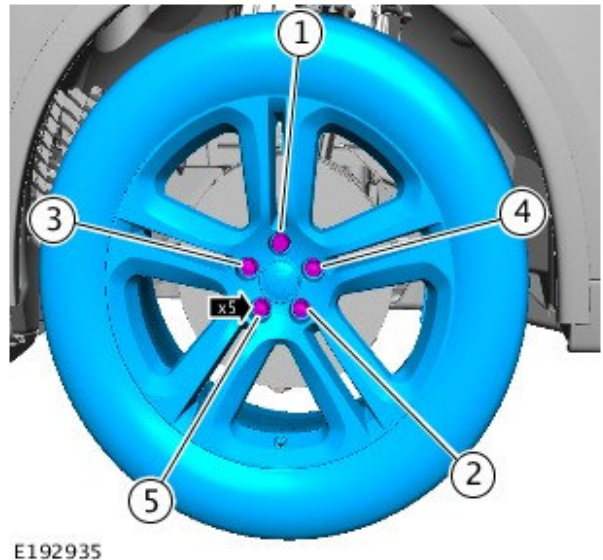

24. Perform Steps 2-23 for the rear right suspension.