



# Service Bulletin

## INFORMATION

**Subject:** Information on Vibration Analysis and Diagnostic

**Models:** 2014 Chevrolet Silverado 1500  
 2015-2016 Chevrolet Silverado  
 2014 GMC Sierra 1500  
 2015-2016 GMC Sierra

**Attention:** This PI also applies to any of the above models that may be North America Export to Middle East, Chile, Peru and Thailand vehicles.

*This PI has been revised to add the 2016 Model Year and update the applicable information below. Please discard PI1354C.*

### Training Available

US Courseware			
Course	Delivery Platform	Course Description	Length
13042.14D1	Virtual Classroom Training (VCT)	Noise, Vibration and Harshness (NVH) 1	1.5 hrs
13042.14D2	Virtual Classroom Training (VCT)	Noise, Vibration and Harshness (NVH)	2.0 hrs
13042.14H	Hands-On Training (est. avl. December 2014)	Noise, Vibration and Harshness (NVH)	8.0 hrs
13042.12W	Web-Based Training	Noise, Vibration and Harshness (NVH)	2.0 hrs
13042.13V	Video On Demand (VOD)	PicoScope Noise, Vibration, and Harshness Diagnostics Overview	15:05 minutes
GMCC Courseware			
13042.12W	Web-Based Training	Noise, Vibration and Harness	—
13042.05D1	Virtual Classroom Training (VCT)	Noise Vibration & Harshness - Session 1	—
13042.05D2	Virtual Classroom Training (VCT)	Noise Vibration & Harshness - Session 2	—
13025.16H	Hands-On Training	Vibration Diagnosis (2 day classroom training)	—

13042.13V	Video On Demand (VOD)	PicoScope Noise, Vibration, and Harshness Diagnostics Overview - VOD	—
-----------	-----------------------	---	---

## Condition/Concern

Some customers may comment about a vibration at speeds of 56-72 km/h (35-45 mph) or 96-120 km/h (60-70 mph), which can be felt in either the seat or steering wheel.

The purpose of this bulletin is to outline the recommendations and procedures for diagnosing and repairing vibrations caused by wheel and tire, axle components and/or propeller shafts.

## Recommendation/Instructions

**Important:** The first step in determining the cause of the vibration is a test drive with the appropriate diagnostic equipment installed on the vehicle. If the correct tools and procedures are not followed, an incorrect diagnosis will result.

### Full Size Truck Vibration Analysis:



1. Inspect the truck for any aftermarket equipment installations. For example: non factory tires, wheels and/or lift kits or leveling kits – shims(1) installed as shown above. Aftermarket equipment does include running boards, bug deflectors, and window shades, etc. Remove any aftermarket that might cause vibration transmission paths.
2. Mark each tire valve stems location on the tire. This will be utilized to check for tire slippage on the rim.



3. Using a Pico Oscilloscope Diagnostic Kit, mount the PicoScope vibration sensor on one of the two locations shown above.

**Note:** Only the use of the Pico Oscilloscope Diagnostic Kit with NVH should be utilized, available from GM Dealer equipment (P/N 733-CH-51450). Previous vibrations tools are NOT recommended due to the types and frequencies producing these vibrations.

- Seat Vibration – mount the sensor to the front right corner of the driver's seat bracket (1).
- Steering Wheel Vibration – mount the sensor to the steering wheel bracket (2) under dash.

**Note:** In some cases, moving the sensor from a vertical position to a horizontal position may indicate higher amplitude and may be beneficial to help in diagnosis.



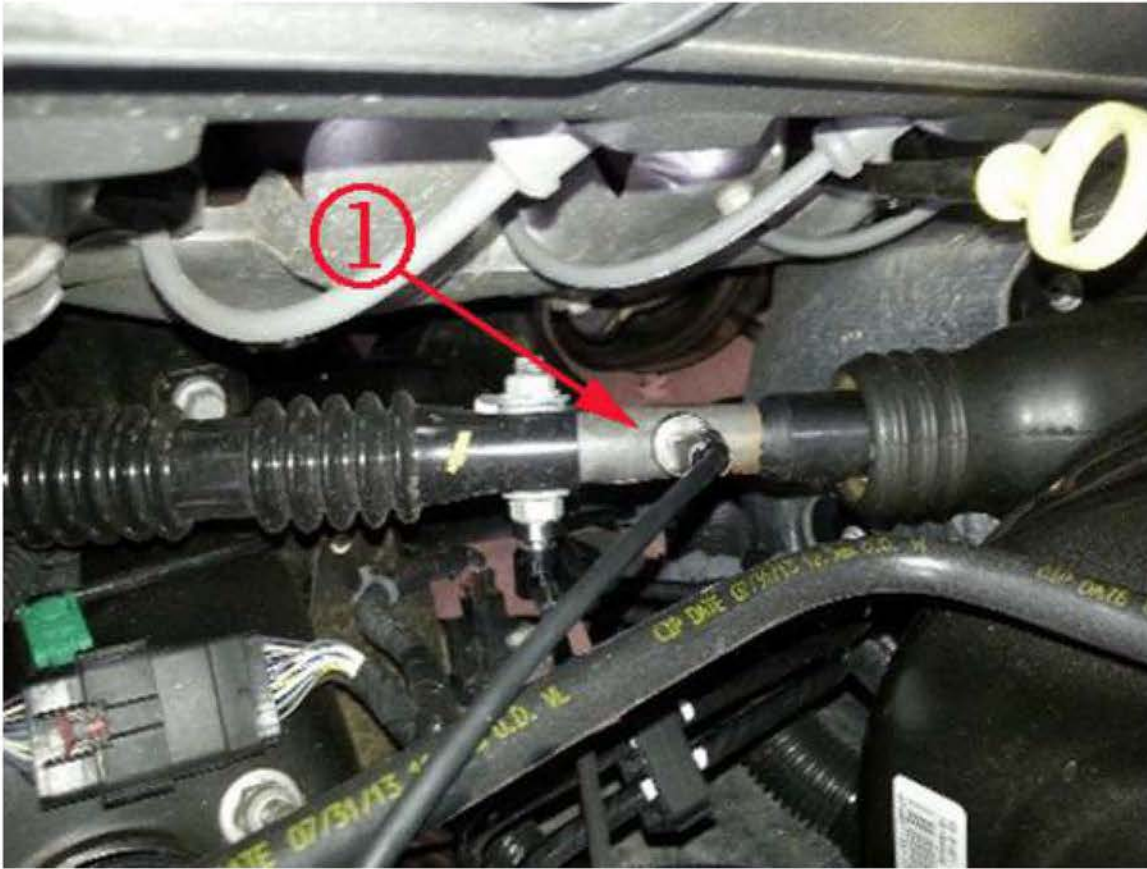

4. This step should be only be used if the vibration can be felt while running the vehicle on the rack. Mount the sensor on the steering shaft(1), under the hood as illustrated above.
5. Measure the vibration. Typically trucks should be driven in M5 to keep from switching in and out of active fuel management (AFM).  
**Note: At the bottom of this bulletin is a required Vibration Diagnostic Worksheet that MUST be completed and is required for the claim payment. Vibration Diagnostic must be retained by the dealership. This worksheet is required to be filled out before calling TAC.**
6. After the road test, verify that the tires have not slipped on the rim (step #2). If slippage has been found, correct the condition prior to any other repair. Refer to the latest version of Corporate Bulletin Number 12-03-10-001: Vibration Shortly After Tires are Mounted/Preventing Vibration from Wheel Slip (Tire Sliding on Wheel).
7. Once the condition has been duplicated on a test drive and the vibration readings have been recorded, bring the vehicle back into the shop and test the vehicle on four jack stands or a suitable hoist. The hoist must support the suspension at the same trim heights as the vehicle would normally sit on the road.
8. With the vehicle properly supported, bring the speed up to the complaint speed and verify that the previously recorded vibration data matches current vibration data being displayed.
9. The test should be performed in both 2 wheel drive and 4 wheel drive, if equipped. If vibration can be duplicated on the rack, the test should be performed a second time with the wheels and tire assemblies removed from the vehicle and the wheel nuts installed to retain the brake discs and/or brake drums. If the vibration has been eliminated with the wheel and tire assemblies removed, focus on the wheel and tire assemblies as the source of the vibration. If the vibration is still present, focus on the vehicle driveline as the source of the vibration.

**Additional Notes for Testing**

- Phasing is typical on these tracks. Test drives should include many turns that can prevent phasing.
- Same test should be conducted after dealer correction to ensure vibration is eliminated throughout the entire test repair phase.

Use the chart below to determine which type of vibration the truck has and what repair procedure should be utilized.

Type of Vibration	Go to Condition
1st Order Tire	1
1st Order Prop Shaft	2

2nd Order Prop Shaft	3
3rd Order Tire Combined with 1st Order Prop	4
Vibration Felt in 4 cylinder mode (AFM) – V6 Engine Only	5
Vibration Felt at Idle Only	6*
<p>*For rough idle and/or vibration at idle in gear – PIP5211: Rough Idle. *For vibration related to AFM in 4 cylinder mode – refer to PIP5228: Vibration During Active Fuel Management V4 Mode Operation 1200–1400 Engine RPM.</p>	

**Important:** Prior to any Road Force Balancing done with the Hunter 9700, please make sure that the wheel assemblies pass the centering test, which is performed using the Hunter 9700 machine.

### Condition 1: 1st Order Tire Suggestions (Freq 11-14 hz at 60 mph or 97 km/h)

#### Measurements

1. Remove the tire and wheel assemblies from the vehicle and perform the Road Force Variation (RFV) measurement.  
**Important:** Prior to taking any measurements, the assemblies MUST all pass a center check.
2. Document the before and after Road Force Variation (RFV) numbers on the vibration worksheet located at the end of this bulletin.

#### Road Force Specifications

P-Metric tires on passenger cars	15 lbs (6.8 kg) or less
P-Metric tires on light trucks	15 lbs (6.8 kg) or less
LT - tires on light trucks	15 lbs (6.8 kg) or less

**Note:** These numbers are lower than what is currently published in service information as some vehicles react to parts that are near the high limit. These numbers SHOULD NOT be used if you do not have a tire speed related disturbance.

#### Repair:

- For any assembly that has an out of balance condition (greater than 0.25oz), remove the weights and correct the condition utilizing normal balancing techniques.
- For any assembly having Radial Force Variation (RFV) measurements beyond the specification above, should be corrected utilizing the Hunter 180 Match Mount Process (See Hunter 180 Match Mount process below) prior to tire replacement. If this does not bring the assembly within specification, the tire should be replaced. The existing vectoring process cannot be utilized on Full size truck rims (except wheel wheels) due to the removal of the out-board flange on the wheel which was utilized for the outboard rim runout measurement. Without this surface, an inaccurate rim runout measurement would exist and negatively affect the vectoring calculation.

#### Additional Notes on Balancing:

- Always perform a centering check.
- The Hunter Balancer/Road Force Balancer should not be set to "Smart Weight."
- All tires need to be balanced under 0.25 oz (both static and dynamic). In many cases, it may be helpful to add weight to only one plane at a time.
- When using the Hunter – Balancer/Road Force Balancer, removal and remounting to the tire balancer should be performed to re-check balance and verify that results are repeatable to 0.25 oz or less.
- Anytime a tire is removed from the wheel, the bare wheel should be mounted back on the vehicle and a runout check be performed on-vehicle. This process not only checks the wheel but also all mounting surfaces and suspension components that may effect runout.

**Important:** When replacing tires, the road force should be checked before a test drive and after a test drive (min of 10-15 miles or 16-24 km/h). Road force on new tires will change dramatically after being warmed up (as much as a 20lb reduction). After the test drive, the tire's road force should be checked. If acceptable RFV cannot be achieved, first try vectoring the tire on the rim before an alternate tire is utilized. Also refer to the Information in the latest version of



Corporate Bulletin Number 13-03-10-002: Diagnostic Tips for Difficult to Resolve Tire/Wheel Vibration Concerns. Some more information is needed on how to check the assemblies for 2nd, 3rd, and 4th order RFV.

#### Hunter 180 Match Mount Process

GM passenger cars have had some limited flangeless wheel applications in the past, but starting with the launch of the 2014 Light Duty Pickup, several new Flangeless wheels were introduced. Flangeless refers to the outboard flange of the wheel where previously a clip-on weight would attach. The new wheels do not have a machined flange for the Hunter Run-out Arm/Wheel to ride on. The previous process for tire and wheel assemblies that had high Road Force, was using the tire Force Matching process. This process requires the use of the Runout Measurement arms on the Hunter Road Force balancer. Without having this machined area, there is not a place for the Runout roller to measure. The Generation 3 and 4 RoadForce balancers have an alternate process called the 180 Match mount. On Gen IV machines this procedure can be found under RoadForce - Procedures - 180 Matching (or by selecting Match Mount without Rim Runout after initial RoadForce measurement).

This process does not use the Runout Arms and instead utilizes the Load Roller to optimize Road Force. While this process requires that the tire may need to be rotated up to 3 times on the rim to obtain the lowest Road Force number, it is the only way for the technician to match mount these wheel and tire assemblies reliably.

For more information on the 180 Matching process, please review the following Hunter Video that outlines the process. <https://youtu.be/nswttgUKstk>

### Condition 2: 1st Order Prop Shaft (Freq 38-44 hz at 60 mph or 97 km/h)

#### Perform Propeller Shaft Runout Measurement (Refer to the SI Document ID# 2084709)

Specification	0.050**
Actual Measurement	
*For Best Result, the maximum runout should be under 0.20." If over, then replace the driveshaft.	

**Note:** These numbers are lower than what is currently published in service information as some vehicles react to parts that are near the high limit. These numbers SHOULD NOT be used if you do not have a propeller shaft speed related disturbance.

#### Check Pinion Flange Runout Measurement

##### Special Tools:

- GE-7872 Magnetic Base Dial Indicator Set, equivalent
- GE-8001 Dial Indicator Set, or equivalent

For equivalent regional tools, refer to the Special Tools and Equipment in SI.

##### Note:

- This measurement procedure is intended to measure propeller shaft runout for prop shaft systems with 2 or 3 U-joints only. This is not for prop systems with only 1 U-joint, or with only constant velocity (CV) joints, and/or coupler assemblies.
- When measuring runout of propeller shafts, do not include fluctuations on the dial indicator due to welds or surface irregularities.
  1. Raise and support the vehicle with the wheels free to rotate. Refer to the Lifting and Jacking the Vehicle in SI.
  2. Place the transmission in NEUTRAL.
  3. Clean the circumference of the propeller shaft of any debris and/or undercoating along the rear of the shaft, where contact of the dial indicator will make to the propeller shaft.
  4. Inspect the propeller shaft for dents, damage, and/or missing weights. Any propeller shaft this is dented or damaged requires replacement.

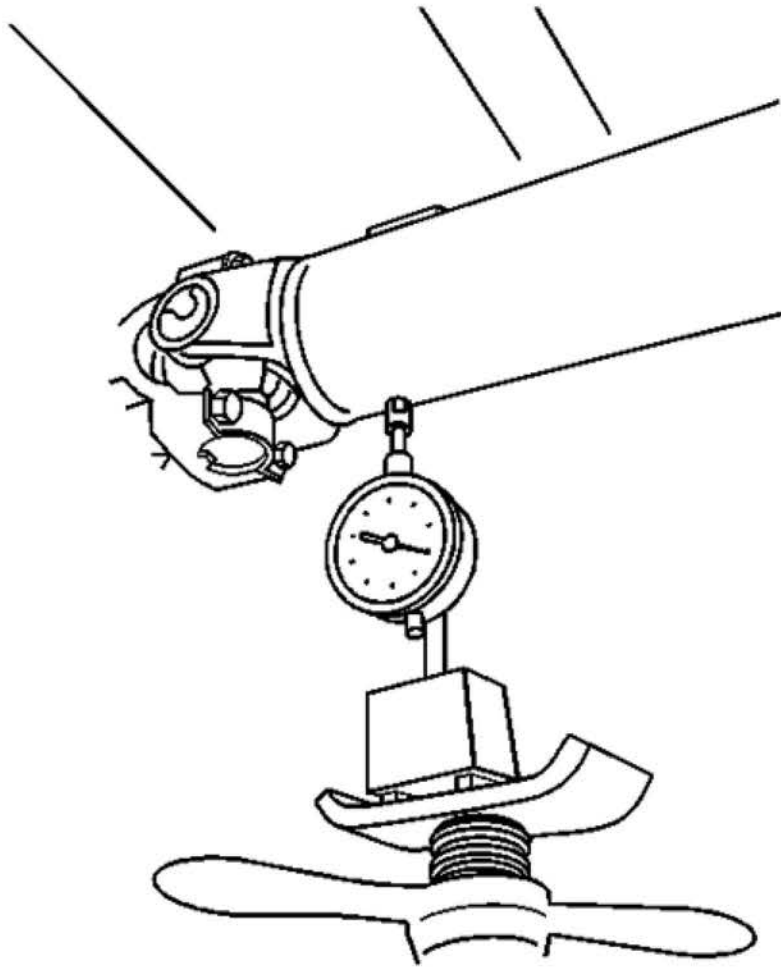

5. Mount the GE-7872 Magnetic Base Dial Indicator Set, or equivalent, or the GE-8001 Dial Indicator Set, or equivalent, to the vehicle underbody or to a service stand positioned just clear of the U-joint yoke weld on the prop shaft.
6. Rotate the drive pinion axle flange, torque tube input flange, transmission output, or transfer case output flange by hand while take runout measurements of the prop shaft. The prop shaft will rotate more easily in one direction than in the other. If necessary, the tire and wheel assemblies and even the brake caliper assemblies can be positioned and supported aside, or the brake drums can be removed from the drive axle to provide axle to provide easier rotation of the prop shaft.
7. Measure and mark the high spot of the propeller shaft. Mark the location of the propeller shaft to flange.
8. Rotate the propeller shaft 180 degrees from its original position on the flange.
9. Perform step six again.
10. If the high spot of the propeller shaft is in the same location as marked in the previous step and the measurement exceeds the maximum prop shaft runout specified, the prop shaft requires replacement before proceeding.  
**Note:** This measurement is focused on pinion flange runout, it is NOT a complete measurement of the prop shaft runout. To fully measure prop shaft runout, measurements must be taken at the front and middle of each prop shaft segments.
11. If the high spot is in a different location, the runout is in the pinion flange or pinion. If this exceeds the maximum allowable runout for the pinion flange, the source of the runout (usually the flange or the pinion itself) must be found.

**Perform Balance Measurement using “Adjustment Procedure Using Oscilloscope” (PicoScope) (Refer to the SI Document ID# 3753593)**

Specification	10 g-cm
Actual Measurement	

For vehicles that are out of balance, perform a system balance. Using the two hose clamp method, the best driveline balance results are obtained under 10g-cm.



### Suggestions:

1. Perform Runout Measurement.
2. Disassembly/reassembly rear yoke joint – checks for shift in U-joint.
3. Evaluation Drive.
4. Perform Runout Measurement.
5. Index 180.
6. Evaluation Drive.
7. Perform Runout Measurement.
8. Evaluation Drive.
9. Balance Shaft with PicoScope.

### Diagnostic Aid:



- Inspect the propeller shaft for dents or damage. There have been many cases of dented propeller shafts.
- For 4WD Trucks, remove the rear propeller shaft, seal output shaft and drive the vehicle in 4WD. If the vibration is gone, the rear prop shaft could be the problem.
- For vehicles with a 3:08 with a one-piece steel shaft, this can be replaced with a one-piece aluminum one that is utilized on all 3:42 and 3:73 ratios (K15543 and K15753 Models only).
- PIP5140: Low Speed Vibration 30-35 mph (48-56 km/h).
- Inspect the transmission output shaft bushing for irregular wear.

### Condition 3: 2nd Order Prop Shaft (Normally a launch shudder or left under hard acceleration)

**Note:** Vehicle rear suspension must be properly supported during the Driveline Angle measurement process in order to record true Driveline Angle measurements.

**Check Driveline Angles (Refer to SI Document ID# 2084724)**

### Suggestion:

1. Check Angle.



2. Disassembly/reassembly rear yoke – check for shift in U-joint.
3. Check Angle.
4. Evaluation Drive.

	Measurement	Notes:
Yoke to Shaft		The first (forward most) U-joint action on a two piece driveshaft system is not canceled out by another U-joint. Because of this, the first U-joint working angle should be between 0.5 and 0.75 degrees.
Front Shaft to Center Support Bearing (if equip)		U-joint pairs cancel each other. Neither U-joint working angle should exceed 4 degrees, nor the allowable range of difference between cancelling U-joint working angles is 0.00 to 1.0 degrees.
Shaft to Diff Yoke		

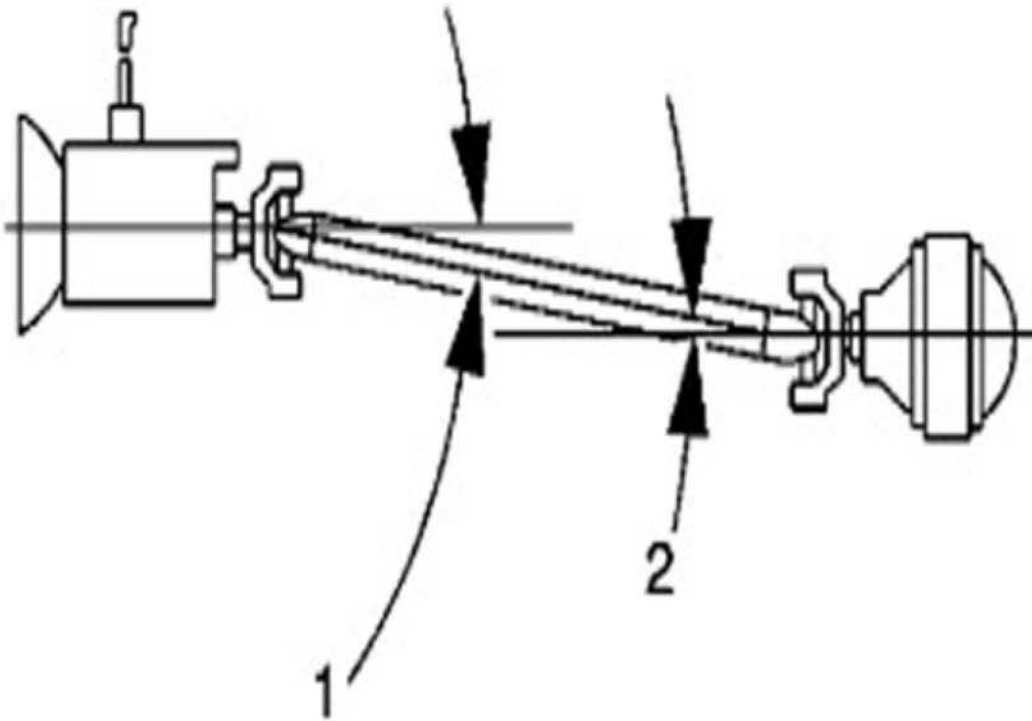

Propeller systems containing only 1 U-joint: The U-joint working angle should be between 1/2 and 3/4 degrees.

Allowable range of difference between cancelling U-joint working angles: 0.25 to 1.0 degrees.

### Shimming

**Important:** This is only be used for trucks that have incorrect working angles.

### Options:

1. Trucks were built prior to 1/1/2015 had a 14 mm spacers under the transfer case (4WD only). Starting with 1/1/2015. The shim was reduce to 7 mm shim which may correct the condition.
2. A 2 degree axle shim (P/N 23469809 – Qty 2) can be placed between the leaf spring pack and the axle perch. To rotate the pinion up to correct this; the “fat end” of the shim must face backwards, to the rear of the truck.

### Center Support Bearing - Two Piece Propeller Only

Change center support bearing shim from 12 mm (0.47 in) to 6 mm (0.24 in) using washers or other means. (If replacing the propeller, the new one will come with 6 mm or 0.24 in shim).

#### Condition 4: 3rd Order Tire with 1st Order Prop

- 3rd Order Tire combined with 1st Order Prop. This type will create a phasing boom. Need to focus on the 1st Order Prop – condition above.

#### Condition 5: Vibration Felt in 4 Cyl Mode (AFM) – V6 Engine Only

Several customers have commented on a vibration felt in the steering wheel or seat during 4 Cylinder Active Fuel Management (AFM) operation. This can be noticed more at 64-72 km/h (40-45 mph) and by lightly accelerating to the point where the engine transitions to 6 cylinders, or V6 mode.

- This type of vibration can be the result of exhaust cross pipe ground out and/or cab mount ground out.

To repair this condition, the three-way catalytic converter settling procedure in PIP5228: Vibration During Active Fuel Management V4 Mode Operation 1200–1400 Engine RPM should be completed.

#### Condition 6: Vibration Felt at Idle Only

- Refer to the PIP5137A: Rough Idle or Vibration In Drive.

#### Other Sources of Vibrations

1. Exhaust resonance – PI1201A: Exhaust Rattle, Buzz, Pop or Whistle.
2. Vibration during active fuel management V4 mode operation – PIP5228. Follow this cab mount settling procedure listed below:

**Warning: When settling the body cushions, do NOT separate the frame from the body more than is necessary. Possible personal injury and damage to multiple parts may result if you do not follow the guides outlined below:**

- Intermediate steering shaft – Do not allow the shaft to extend more than 25 mm (1 in).
- Fuel tank filler hose – Do not stretch the hose excessively.
- Tail/Turn signal lamp wiring/rear lamps junction block – Leave slack in the wires
- Park brake cable – Leave slack in the cable
- Body ground straps – Leave slack in the wire
  - ⇒ The technician should first loosen the fastener located at the center of each body mount (6 for a regular cab, 8 for crew and double cab).
  - ⇒ Using a large angled pry bar, lift up the cab body slightly to settle / relax it. Perform this at each mount location one at a time.
  - ⇒ Repeat this cab mount settling process twice, to confirm the mounts are settled / relaxed.

Visually verify that the cab to box alignment is correct before re-torquing all mounts to specification found in Service Information, body repair, frame and under body section.

#### The cab / body mount position location

The numbers in the picture below indicate the specific mount position. The mounts on the passenger side of the vehicle are identified the same way. This will assist the technician to identify the correct location of each mount so they can be torque to the proper specification.



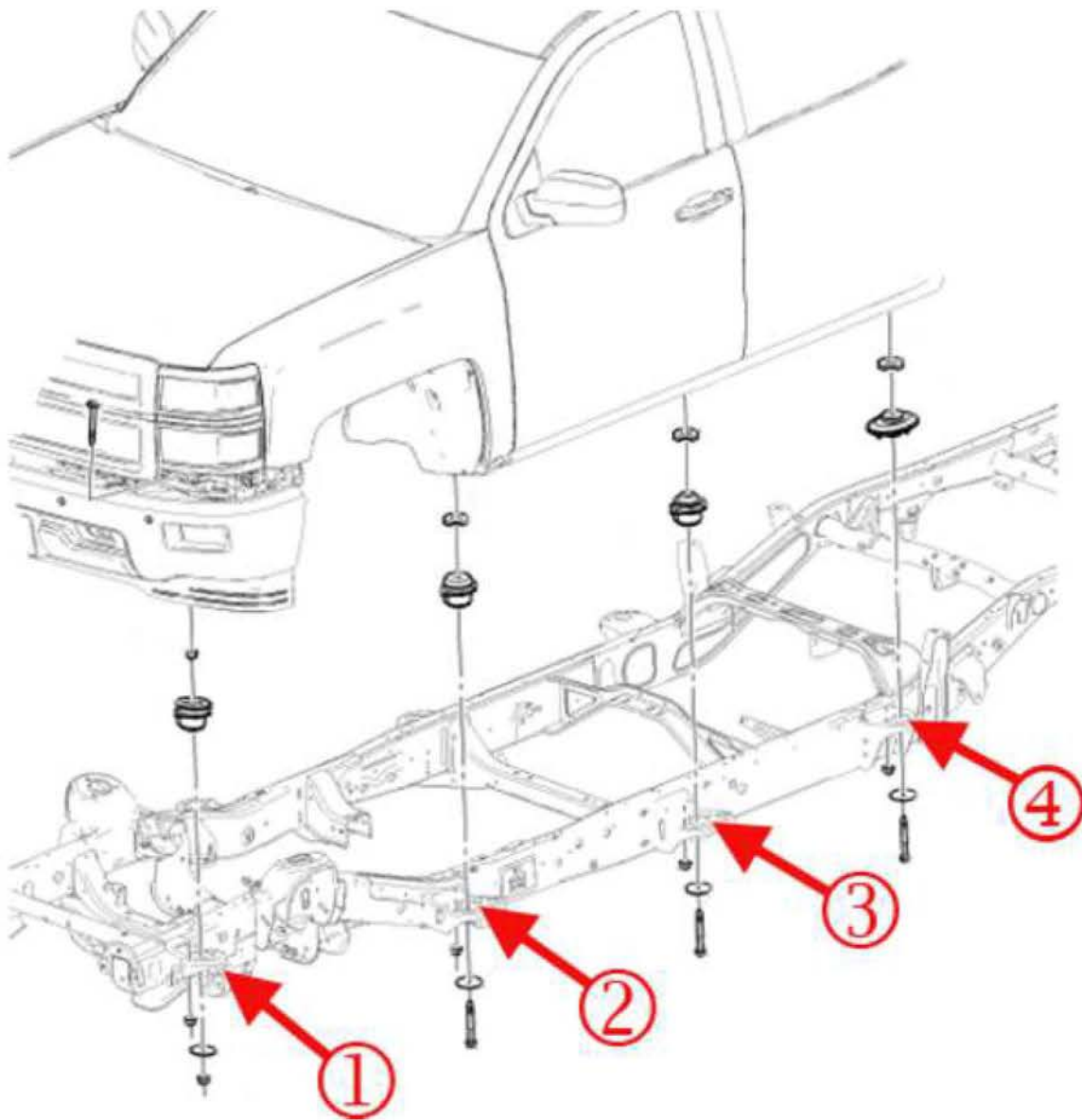

- 1 = body mount cushion front
- 2 = body mount cushion position number 1
- 3 = body mount cushion position number 2
- 4 = body mount cushion position number 3

3. Pitchline runout – Pitchline runout will normally show as a 1st order tire vibration on the PicoScope. If after correcting tire(s) with excessive Road Force a vibration exists, remove differential cover and check ring gear backlash. Every tooth should be checked for excessive backlash. If there is more than 0.0762 mm (0.003 in) of variation, the ring gear and/or differential should be replaced to correct the condition (SI Document ID# 3269088, 3620298) (PIP4148A).

### Backlash Adjustment Procedure

#### Special Tools:

- J-8001 Dial Indicator Set
- J-25025 Guide Pins

#### Note:

- Ensure that the side bearing surfaces in the axle housing are clean and free of burrs. If the original bearings are to be reused, the original bearing cups must also be used.
- The differential side bearings must be initially preloaded in order to determine the backlash of the gear set. After the backlash is set, the final bearing preload is set.
- Mark the bearing caps left or right sides.

1. Measure the rotating torque of the drive pinion and differential assembly. Refer to the Differential Drive Pinion Gear Bearing Replacement in SI.

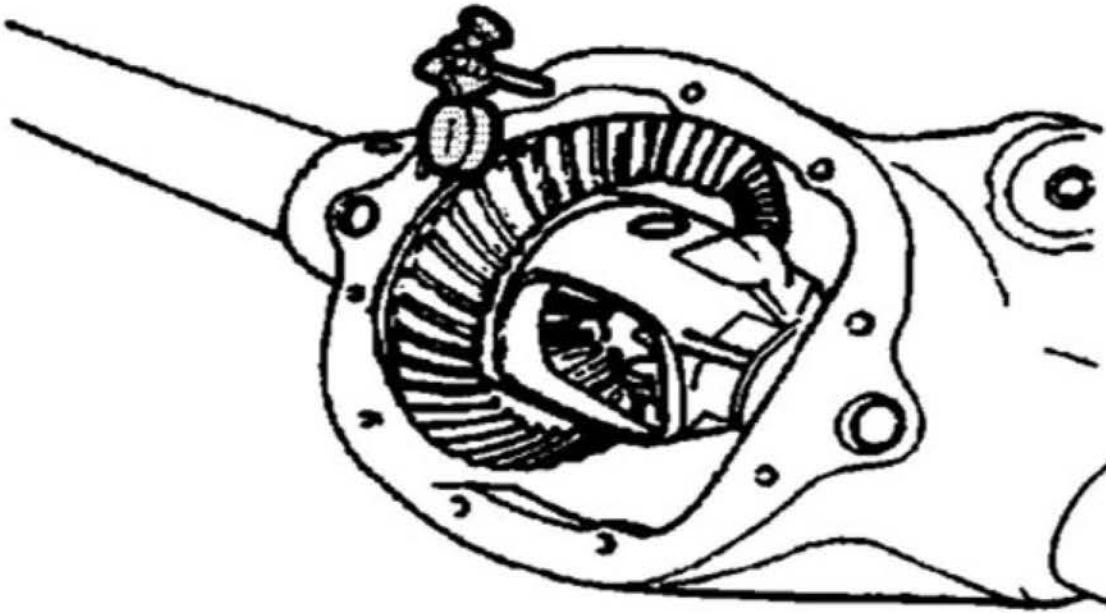

2. Install the J-25025 pins and the J-8001 indicator to the axle housing.

**Note:** Preload the dial of the J-8001-3 indicator approximately  $\frac{3}{4}$  of a turn and zero the gauge.



**Note:** The illustration above is for reference only. The differential does NOT need to be removed from the vehicle.



3. Set the J-8001-3 indicator (1) so that the stem is aligned with the gear rotation (1) and square to the tooth angle.
4. Hold the drive pinion stationary and move the ring gear back and forth.
5. Repeat the measuring procedure at **each tooth** around the ring gear.
6. The difference between the backlash at all of the measuring points should not vary by more than 0.05mm (0.002 in).
7. If the difference between the backlash at all of the measuring points varies by more than 0.05 mm (0.002 in), inspect for burrs, a distorted case flange or uneven bolting.
8. If the difference between all the measuring points is within specifications, the backlash at the minimum lash point measured should be 0.08-0.25mm (0.003-0.010 in) with a preferred backlash of 0.13-0.18 mm (0.005-0.007 in).

**Note:**

- Increasing or decreasing the shim thickness by 0.05 mm (0.002 in) will change the backlash adjustment approximately 0.03 mm (0.001 in).
  - If the backlash is less than, select a smaller shim than the one that was removed. For example, to INCREASE the backlash by 0.05mm (0.002 in), select a shim that is 0.10 mm (0.004 in) thinner than the shim that was removed.
  - If the backlash is larger than, select a larger shim than the one that was removed. For example, to DECREASE the backlash by 0.05 mm (0.002 in), select a shim that is 0.10 mm (0.004 in) thicker than the shim that was removed.
9. Install the selected shim.
 

**Caution:** Use the correct fastener in the correct location. Replacement fasteners must be the correct part number for that application. Do not use paints, lubricants, or corrosion inhibitors on fasteners, or fastener joint surfaces, unless specified. These coatings affect fastener torque and joint clamping force and may damage the fastener. Use the correct tightening sequence and specifications when installing fasteners in order to avoid damage to parts and systems. When using fasteners that are threaded directly into plastic, use extreme care not to strip the mating plastic part(s). Use hand tools only, and do not use any kind of impact or power tools. Fastener should be hand tightened, fully seated, and not stripped.
  10. If the backlash is too small, increase the backlash using the following procedure:
    - 10.1. Remove the bearing cap bolts and the bearing caps.
 

**Note:** Mark the bearing cups and the shims left or right.
    - 10.2. Remove the differential case assembly with the bearing cups and the shims.
 

**Note:** Measure the production shim or the shim and service spacer in 3 locations.  
Measure each shim separately.
    - 10.3. Measure the thickness of left side shim pack.
 

**Note:** If the original shim is cast iron production shim, assemble the shim pack using a service spacer and service shims. For example, to increase the backlash by 0.05 mm (0.002 in), remove 0.10 mm (0.004 in) in of thickness from the left side shim pack.
    - 10.4. Calculate the average of the 3 measurements for each shim.
 

**Note:** If the original shim is cast iron production shim, assemble the shim pack using a service spacer and service shims. For example, to increase the backlash by 0.05 mm (0.002 in), remove 0.10 mm (0.004 in) of thickness from the left side shim pack.
    - 10.5. Assemble a new left side shim pack by decreasing the appropriate amount of thickness from the original left side shim pack.
 

**Note:** Measure each shim separately.
    - 10.6. Measure the thickness of right side shim or the shim and service spacer in 3 locations.
 

**Note:** Add the average of each of the shim measurements together. Record the measurement. This is the thickness for the right side shim pack.
    - 10.7. Calculate the average of the 3 measurements for each shim.
    - 10.8. Assemble a new right side shim pack by increasing the appropriate amount of thickness to the original right side shim pack. If the original shim is cast iron production shim, assemble the shim pack using a service spacer and service shims. For example, to increase the backlash by 0.05 mm (0.002 in), add 0.10 mm (0.004 in) of thickness to the right side shim pack.
  11. Use the following procedure to decrease the backlash if the backlash is too large:
    - 11.1. Remove the bearing cap bolts and the bearing caps.
 

**Note:** Mark the bearing cups and the shims left or right.
    - 11.2. Remove the differential case assembly with the bearing cups and the shims.
 

**Note:** Measure the production shim or the shim and service spacer in 3 locations. Measure each shim separately.
    - 11.3. Measure the thickness of left side shim pack.
 

**Note:** Add the average of each of the shim measurements together. Record the measurement. This is the thickness for the left side shim pack.
    - 11.4. Calculate the average of the 3 measurements for each shim.
    - 11.5. Assemble a new left side shim pack by increasing the appropriate amount of thickness to the original left side shim pack. If the original shim is

cast iron production shim, assemble the shim pack using a service spacer and service shims. For example, to increase the backlash by 0.05 mm (0.002 in), add 0.10 mm (0.004 in) of thickness to the left side shim pack.

**Note:** Measure the shim or the shim and service spacer in 3 locations. Measure each shim separately.

11.6. Measure the thickness of right side shim pack.

**Note:** Add the average of each of the shim measurements together. Record the measurement. This is the thickness for the right side shim pack.

11.7. Calculate the average of the 3 measurements for each shim.

11.8. Assemble a new right side shim pack by decreasing the appropriate amount of thickness to the original right side shim pack. If the original shim is cast iron production shim, assemble the shim pack using a service spacer and service shims. For example, to decrease the backlash by 0.05 mm (0.002 in), remove 0.10 mm (0.004 in) of thickness to the right side shim pack.

12. Install the differential case assembly with the bearing cups.
13. Install the left side service shims between the axle housing and the differential case.
14. Install the right side service shims between the axle housing and the differential case.

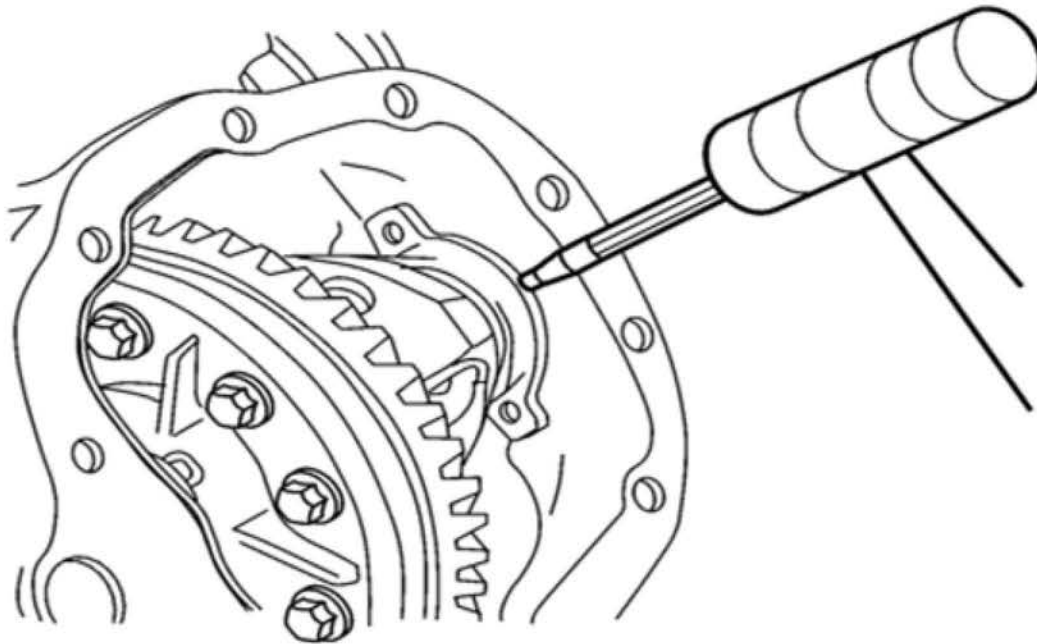

**Note:** The service spacers must be installed between the service shim(s) and the axle housing.

15. Using the brass drift for 9.5/9.76 axle, install the left side service spacer.
16. Recheck the backlash and adjust, if necessary.
17. Install the bearing caps and bolts and tighten to 85 N•m (63 lb ft).
18. Recheck the backlash and adjust, if necessary.
19. Once backlash is correct, perform a gear tooth contact pattern check in order to ensure proper alignment between the ring and pinion gears. Refer to the Gear Tooth Contact Pattern Inspection in SI.

**Note:** Recheck the backlash following the steps above to verify that the backlash is within specifications.

20. Tighten the differential bearing cap bolts to 85 N•m (63 lb ft).
21. Measure the drive pinion and differential case side bearing preload and adjust, if necessary following the steps above.
22. Once the backlash and bearing preload is correct, perform a gear tooth contact pattern check in order to ensure proper alignment between the ring and pinion gears. Refer to the Gear Tooth Contact Pattern Inspection in SI.

Once all areas of vibrations has been reduced, if there is still vibration that the customer is concerned about, the following diagnosis maybe helpful to determine if a shock issue exists.

**Warning:** The following items should NOT be utilized until the source of the problem has been corrected.



## Potential Vibration/Rough Ride:

### Condition/Concern

The shock issues below DO NOT cause a vibration, it will only make an existing vibration feel worse. In some cases, a vibration that would not normally be a customer concern may now be felt due to a bad shock. But in general, the original source of the vibration, whether it is the wheels, tires, propeller shaft, etc, will have to be corrected. When diagnosing a vibration issue, there have been reports of the shocks amplifying the vibration felt inside the truck. Engineering has found that some shocks may have been built with contaminated shock oil. This may cause the shocks to dampen incorrectly.

### This only applies to the following shocks:

- Rear- Only trucks listed with the Z71 option (RPO Z71, these shocks will be white in color)

### Recommendation/Instructions:

Two checks are needed to be performed to verify if the shocks could be an issue:

1. Check the date code located on the bottom of the shock. The first 8 digits are the GM part number. The next 5 digits are the supplier part number. The last 5 digits will be the date code. Any shock built before A1474 could have an issue. The date code format is as follows: 1st digit is the plant, next 3 digits are the day of the year and the last digit is the last number of the year.

#### Example:

- A14743C
- A = Plant
- 147 = 147th Day of the Year
- 4 = 2014
- 3C = Drawing Change Level

2. If the rear shocks are built before this date code, they will have to be removed for a dynamic test.

### Dynamic Test (Rear Shock – Z71 option only)

Starting with a fully extended shock, compress the rod taking notice of the first 10 millimeters of travel. A good shock will not have any free play and there will be immediate resistance to being compressed. A shock with an issue will have several millimeters of free play (no resistance) before feeling the resistance from being compressed. Replace any shocks with excessive free play. In most cases, the rear shocks will be the issue.

## Warranty Information

For vehicles repaired under warranty, use:

Labor Operation	Description	Labor Time
3080138*	Perform Pico Scope Vibration Measurement and Road Test	0.5 hr
8080108*	Perform Road Force Measurement	0.9 hr
	Add time to vector each tire correction (Before and after Road force number should be noted on Vibration worksheet)	0.2 hr
3080088*	Perform Prop Shaft Measurement and Balance (two hose clamp method)	0.8 hr
**	Replace Tire(s)	Use Published Labor Operation Time
8033641	Front Shock Absorber, Shock Absorber Component, or Spring Replacement - Both Sides	1.2 hrs
8044751	Rear Shock Absorber Replacement - Both Sides	0.7 hr

\*This is a unique Labor Operation for Bulletin use only. It will not be published in the Labor Time Guide.

\*\*Use the appropriate labor operation code in SI specific to the manufacturer of the tire being replaced.

## Vibration Diagnostic Worksheet

Vibration Felt In:			
Seat:	Steering Wheel:	Other:	
Complaint Speed:		VIN:	
Year:		Model:	
Symptom:			
Engine:		Engine Speed:	
Tire Brand:		Tire Size:	
Axle Ratio:		Gear:	
TPC Spec:			
Primary			
Frequency:		Type (circle): T1 T2 T3 E1 E4 P1 P2	
		Other:	
Measurement of vibration is M/g's (# of runs? Peak, Average, and Avg of Peaks?)			
_____			
Source of Vibration (Based PICO)			
_____			
Secondary			
Frequency:		Type (circle): T1 T2 T3 E1 E4 P1 P2	
		Other:	
Measurement of vibration is M/g's (# of runs? Peak, Average, and Avg of Peaks?)			
_____			
Source of Vibration (Based PICO)			
_____			

**Condition 1: Road-Force Measurements**

Before Repairs		
	Ounces	Road Force (Lbs)
Right Front		
Left Front		



Right Rear		
Left Rear		
<b>After Repairs</b>		
	<b>Ounces</b>	<b>Road Force (Lbs)</b>
Right Front		
Left Front		
Right Rear		
Left Rear		

GM bulletins are intended for use by professional technicians, NOT a "do-it-yourselfer". They are written to inform these technicians of conditions that may occur on some vehicles, or to provide information that could assist in the proper service of a vehicle. Properly trained technicians have the equipment, tools, safety instructions, and know-how to do a job properly and safely. If a condition is described, DO NOT assume that the bulletin applies to your vehicle, or that your vehicle will have that condition. See your GM dealer for information on whether your vehicle may benefit from the information.



WE SUPPORT VOLUNTARY TECHNICIAN CERTIFICATION