



Service Bulletin

INFORMATION

Subject: Diagnostic Tip for Intermittent Crank/No Start After Removal of Camshaft Sprockets

Models: 2013-2016 Buick Encore
2014-2015 Cadillac ELR
2011-2015 Chevrolet Volt
2011-2016 Chevrolet Cruze (VIN P for 2016)
2012-2016 Chevrolet Sonic
2013-2016 Chevrolet Trax
2012-2015 Opel Ampera
Equipped with 1.4L Engine (RPOs LUU, LUV or LUJ)

Attention: This PI also applies to any of the above models that may be Export from North America vehicles.

This PI has been revised to update the Model Years. Please discard PI1237A.

Condition/Concern

Some customers may comment on an intermittent crank/no start. After cycling the key, the vehicle will start. This may be caused after having the camshaft sprockets being removed for any type of engine service performed.

Recommendation/Instructions

The exhaust and intake camshaft position exciter wheel must be installed properly with special tool EN-49977-100, fully seated on the cylinder head, before tightening the camshaft sprocket bolt. Refer to the pictures below for proper alignment installation and tool usage.

Exciter Wheel (1)

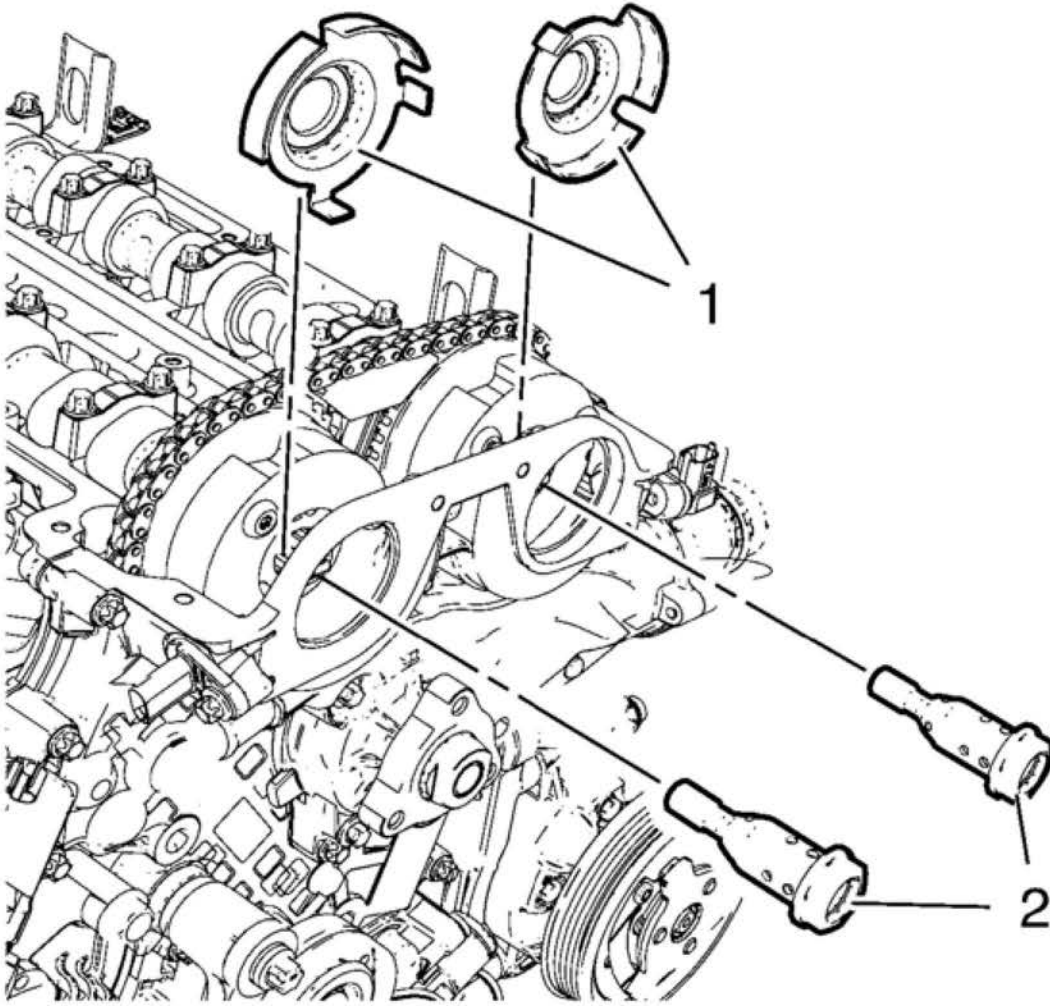

Rear Cylinder Head with Tool Showing Proper Exciter Wheel Alignment



Front Cylinder Head with Tool Showing Exciter Wheel Misalignment



Exhaust Exciter Wheel Incorrect Alignment



Exhaust Exciter Wheel Correct Alignment

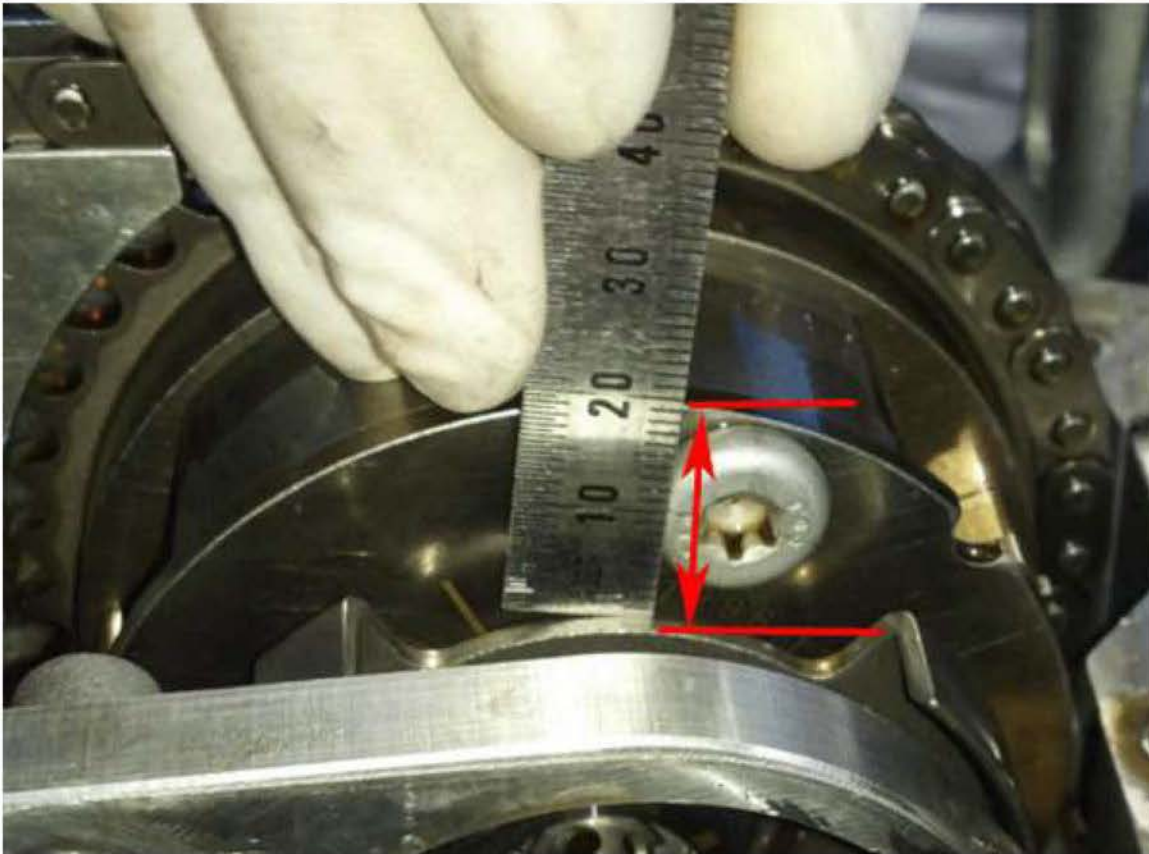

GM bulletins are intended for use by professional technicians, NOT a "do-it-yourselfer". They are written to inform these technicians of conditions that may occur on some vehicles, or to provide information that could assist in the proper service of a vehicle. Properly trained technicians have the equipment, tools, safety instructions, and know-how to do a job properly and safely. If a condition is described, DO NOT assume that the bulletin applies to your vehicle, or that your vehicle will have that condition. See your GM dealer for information on whether your vehicle may benefit from the information.



WE SUPPORT VOLUNTARY TECHNICIAN CERTIFICATION