



Countries: AUSTRALIA, BAHAMAS, BOLIVIA, BRAZIL, BELIZE, CANADA, CHILE, COLOMBIA, COSTA RICA, DOMINICAN REPUBLIC, ECUADOR, EL SALVADOR, TRINIDAD AND TOBAGO, UNITED STATES, URUGUAY, VENEZUELA, ARUBA, NICARAGUA, PERU, PUERTO RICO, Curaçao, GUATEMALA, GUYANA, HAITI, HONDURAS, JAMAICA, PANAMA, SOUTH AFRICA

Availability: ISIS, Bus ISIS, FleetISIS, Body Builder, IsSIR

Major System: BRAKES

Current Language: English

Other Languages: [Français](#), [Español](#).

Viewed: 11174

Document ID: IK0400057

Revision: 8

Created: 2/11/2009

Last Modified: 8/24/2016

Author: Charles Schroeder

[Less Info](#)

Hide Details

Coding Information

Copy Link 	Copy Relative Link 	Bookmark View My Bookmarks	Add to Favorites 	Print 	Edit Document 	Provide Feedback 	Helpful 908	Not Helpful 1026
----------------------	-------------------------------	--	-----------------------------	------------------	--------------------------	-----------------------------	---------------------------	--------------------------------

Title: 07 and Newer Brake Light Operation on HPV, ProStar and LoneStar with Air Brakes

Applies To: 07 and newer HPV ProStar LoneStar with Air Brakes

Change Log

Please refer to the change log text box below for recent changes to this article:

08/24/2016 - Updated the NOTE in Step 7 for vehicles with 2 brake switches. Both switches must be unplugged to check supply voltage.

05/12/2016 - Added component location.

07/24/2015 - Corrected voltage for Step 7 for vehicles with 2 brake switches. Both switches must be unplugged to check for supply voltage.

11/10/2014 - Updated Layout. Step based diagnostics. Added ABS fault SID 55 FMI 2 with Cummins Engine

10/16/2014 - Initial Article Release

Description

- On vehicles with air brakes, the zero volt reference signal is supplied to brake switch 1 HPV (1823) ProStar/LoneStar (1806) terminal D from Body Controller connector (J5) 1602-E5. (Only one switch is used in tractor applications).
- When the key is in the ignition position, the Body Controller will supply 12 volts to the stop light switch 1 HPV (1823) ProStar/LoneStar (1806) terminal C.
 - When the key is in the off position the Body Controller will supply 5 volts to the stop light switch terminal C of the switch instead of 12 volts.
- A 6.8 volt Zener diode, inside the switch body is wired in parallel with the switch contacts. The diode allows current to pass through it when the key is in the ignition position and 12 volts is applied to the switch. The diode prevents current from passing through it when the key is off and 5 volts is applied to the switch. When the key is on and the brake is not applied, the BC monitors the voltage drop across the diode and resistor in the switch. If there is an open in the brake switch circuits there will be no voltage drop and the BC will set a fault. The diode is required to block current flow when the key is off, preventing the circuits from putting a drain on the battery.

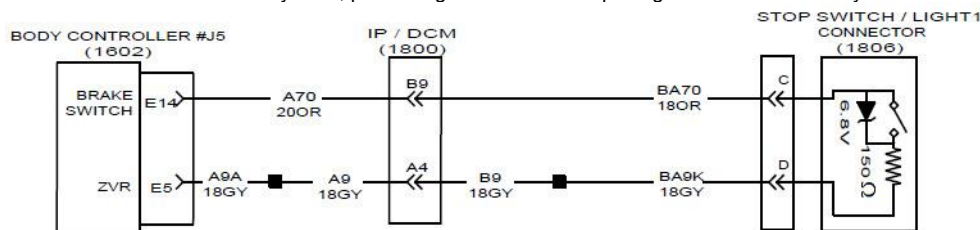

- A 150 ohm resistor, inside the switch body, is wired in series with the switch. The BC senses the voltage drop across this resistor to check for a short to ground in the brake switch circuits between the brake switch and the BC. If there is a short, 12 volts from the BC will be pulled to ground and the BC will set a fault.
- When the brake switch is closed the voltage drop will change and the BC will sense that the brake is applied.
- Diagnostics must be performed key on only. The brake switch input is both an analog input and a digital input. The digital input is used to signal the microprocessor to switch on the brake lights. The analog input is used for brake switch diagnostics. The Body Controller does not perform switch diagnostics with the key switch off; this is because it only uses the digital input when the key is off.

Symptom(s)

Diagnostic Trouble Code(s) & Dashboard Indicator Light(s):

DTC / Light	Module	Description
SPN 597 FMI 0	Body Controller	Brake Switch reading above normal range
SPN 597 FMI 1	Body Controller	Brake Switch reading below normal range
SPN 597 FMI 2	Body Controller	Brake Switch inputs do not match
SPN 597 FMI 7	Body Controller	Brake Switch stuck open or closed
SID 55 FMI 2	ABS ECU	Stop Lamp Switch Defective ** Cummins Engine only

Customer Observations or Concerns:

- Brake Lights Stay On
- Brake Lights Not Working
- ABS Light

For instructions on retrieving fault codes with DLB please follow [IK2600036 - Retrieving Fault Codes with DLB](#)

Special Tool(s) / Software

Tool Description	Tool Number	Comments	Instructions
Diamond Logic Builder		EZ-Tech Software	
Cummins INSITE		EZ-Tech Software	
Fluke DVOM Universal	ZTSE4357		

Service Parts Information

Kit Description	Part Number	Quantity Required	Notes
Kit, Stop Light Switch	2505670C92	1	Certain applications may have 2

Component Location

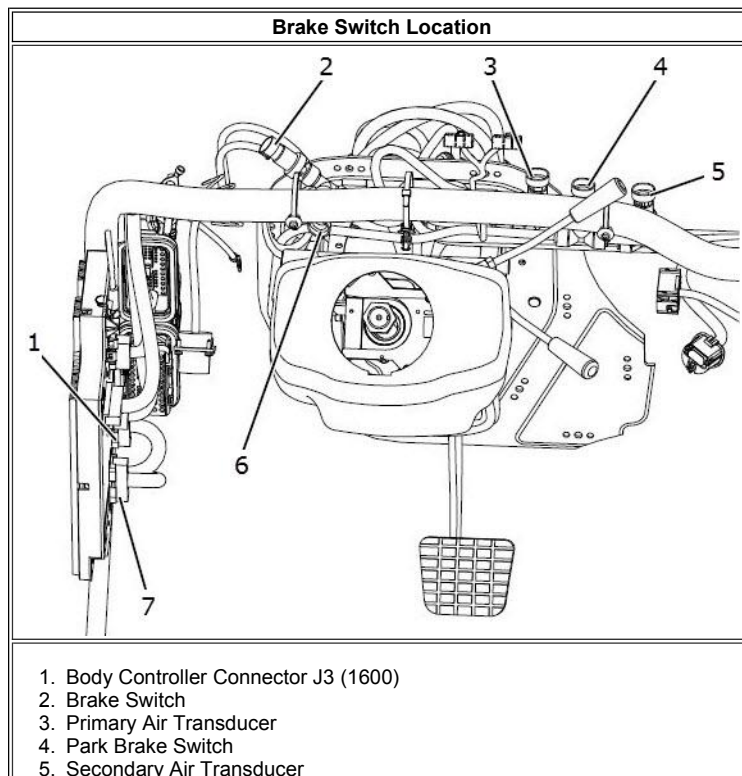

- 6. Brake Application Transducer
- 7. Body Controller Connector J5 (1602)

Diagnostic Step(s)

If you have fault code SID 55 FMI 2 in the ABS ECU with a Cummins powered vehicle, refer to Step 8.

Step	Action	Decision
1	Verify the Body Controller is powered up properly. <ul style="list-style-type: none"> • Follow IK0800092 - The First Check to make when Troubleshooting any Body Controller or ESC Issue 	Yes: Go to step 2
	Is the Body Controller powered up properly with Battery, Ignition, Accessory and Grounds?	No: Repair power or ground circuits as needed. Re-check operation.

Step	Action	Decision
2	Check the faults in the Body Controller using DLB. <ul style="list-style-type: none"> • For instructions on retrieving fault codes with DLB please follow IK2600036 - Retrieving Fault Codes with DLB 	Yes: Go to step 3
	Are brake switch faults present?	No: Go to Step 8

Step	Action	Decision
3	Open a session in DLB for the Brake Switch feature <ul style="list-style-type: none"> • 0595AAD should be the feature you will use • Refer to IK2600008 - How to Diagnose Electrical Problems with Diamond Logic® Builder for more information on making a session from a feature. • You must be in a diagnostic mode with the key on 	Continue to Step 4

Step	Action	Decision
4	Monitor the Value for Brake_Analog_Switch_Raw_Signal with the brakes applied and again with the brakes released. <ul style="list-style-type: none"> • Refer to Figure 1 for Signals and Specifications. 	Yes: Go to step 5
	Is Brake_Analog_Switch_Raw_Signal in spec with brakes applied and brakes released? NOTE: The Body Controller only processes the Brake_Analog_Switch_Raw_Signal when the key is on. This signal is ignored when the key is in the off position.	No: Go to Step 7

Step	Action	Decision
5	Monitor the Value for Brake_Switch_Signal with the brakes applied and again with the brakes released. <ul style="list-style-type: none"> • Refer to Figure 1 for Signals and Specifications. 	Yes: Go to step 6
	Is Brake_Switch_Signal in spec with brakes applied and brakes released?	No: Go to Step 7

Step	Action	Decision
6	Monitor the Value for Brake_Switch with the brakes applied and again with the brakes released.	

<ul style="list-style-type: none"> Refer to Figure 1 for Signals and Specifications. <p>Is Brake_Switch in spec with brakes applied and brakes released?</p>	<p>Yes: Brake Switch signals in DLB are correct. Verify fault and check for an intermittent fault occurrence. Open a Tech Service Case File for further assistance if needed.</p> <p>No: Go to Step 7</p>
---	---

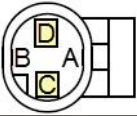
Step	Action	Decision
7	<p>Unplug the connector from the brake switch. (The key should still be on).</p> <ul style="list-style-type: none"> Inspect terminals on the sensor and connector. Verify all terminals are fully seated and locked. Measure the voltage from the Brake Switch connector Terminal C to Terminal D. <p>Is 11.3 ± 0.5 Vdc present?</p> <div style="text-align: center;">  </div> <div style="background-color: #90EE90; padding: 2px; margin: 5px 0;">NOTE:</div> <p>This step will need to be performed on both brake switch connectors for applications with 2 brake switches, and both brake switch connectors need to be unplugged. If either brake switch is plugged in during this voltage check, you will show approx. 7.3v on the volt meter. The 2nd brake switch will be wired to 1602-E15.</p>	<p>Yes: Replace Brake Switch and re-check operation and faults.</p> <hr/> <p>No: Inspect wiring from Body Controller 1602-E14 to Brake Switch Connector and 1602-E5 to Brake Switch Connector. Inspect all terminals and connectors. Perform continuity checks on the wiring as needed. Repair as needed. Re-check operation and faults.</p>

Step	Action	Decision
8	<p>Check the faults in the ABS ECU.</p> <p>Are brake switch or stop lamp switch faults present?</p>	<p>Yes: Check the Parameters using Cummins INSITE. Correct if needed. Refer to Figure 2.</p> <p>No: No fault found. Verify complaint. Check for intermittent issue. Open a Tech Service Case File for further assistance if needed.</p>

Figure 1

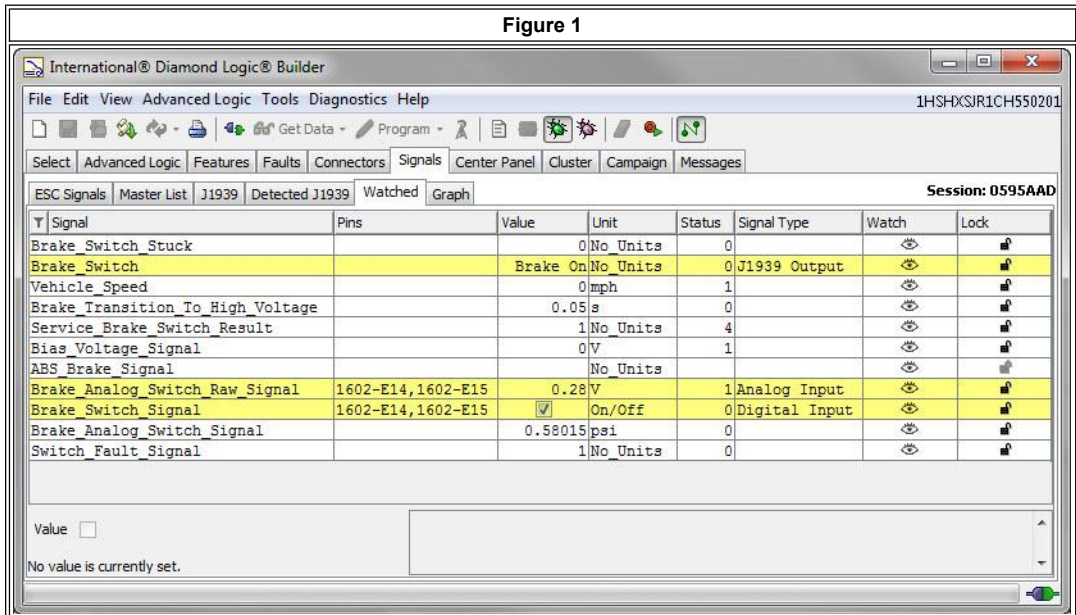

SIGNAL	BRAKE PEDAL STATE	VALUE
Brake_Analog_Switch_Raw_Signal	Applied	0.28v
Brake_Switch_Signal	Applied	Checked
Brake_Switch	Applied	Brake On
Brake_Analog_Switch_Raw_Signal	Released	1.6v
Brake_Switch_Signal	Released	No Check
Brake_Switch	Released	Brake Off

- Return to [Step 4](#)
- Return to [Step 5](#)
- Return to [Step 6](#)

Figure 2

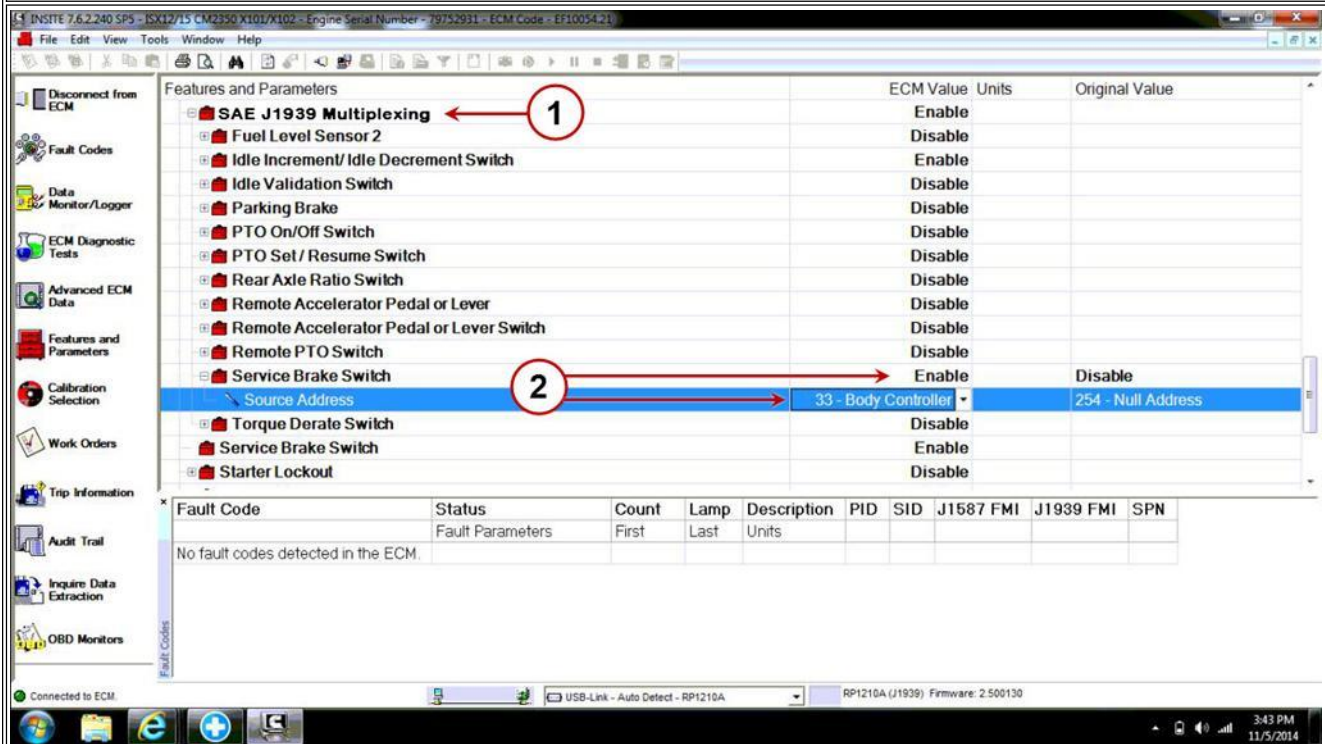

1. Look in the SAE J1939 Multiplexing Parameter
2. Ensure the Service Brake Switch is Enabled and set to 33 - Body Controller

Warranty Information

Warranty Claim Coding:

Group:	08817 - Lighting Systems (Tail / License / Rear Stop / Rear Turn / Backup Lights)
Noun:	863 - Switch, Stoptlight - Air

Standard Repair Time(s):

Step	Description	Chassis	Engine	SRT	Hours
7	Wiring Repair(s), Perform	All Models		A08-2001A A08-2002A A08-2003A A08-2004A A08-2005A	Click Here
7	Stop Light Switch, Replace	4300, 4400 7300, 7400, 7500 7600 8600 ProStar LoneStar All Models		KL08-8863A M08-8863A N08-8863A Q08-8863A R08-8863A S08-8863A A08-3580	Click Here
8	Change Parameter	All Models	Cummins	A12-T1	0.4

Other Resources

- [Medium Duty Diagram](#)
- [LoneStar and ProStar Diagram](#)
- [Master Service Information Page](#)
- [S08293 Advanced Electrical Guide](#) - More information on the Brake Switch starts on Page 40

 Hide Details	Feedback Information
	Viewed: 11173 Helpful: 908 Not Helpful: 1026
No Feedback Found	

Copyright © 2016 Navistar, Inc.