

Subject: PASSENGER-SIDE SEAT WARMER IS SLOW TO WARM UP - (CLOTH SEAT ONLY)	Bulletin No: 09-035/16
	Last Issued: 05/19/2016

APPLICABLE MODEL(S)/VINS

2016 CX-5 vehicles (equipped with cloth seats only) with VINs between JM3KE*****600001 - 772816 (produced from Nov. 3, 2014 to Feb. 1, 2016)

DESCRIPTION

Some customers may complain that the passenger-side seat warmer is slow to get warm, compared with the driver-side seat warmer.

Following a change to the seat weight sensor, urethane pads were added to the passenger-side seat cushion to improve seating comfort. Due to the addition of the urethane pads (which were not installed on the driver-side seat), it takes longer for the passenger-side seat to warm up.

To eliminate this concern, the heater wattage for the passenger-side seat warmer has been increased. Also, the Coupler, Box (Seat Warmer Control Unit) has been changed to cope with the increased wattage.

Customers having this concern should have their vehicle repaired using the following repair procedure.

REPAIR PROCEDURE

1. Verify the customer concern.
2. Replace the **Heater/Pad (R) Front Seat Cushion** and **Heater/Pad (R) Front Seat Back** and the **Coupler, Box (Seat Warmer Control Unit)** with modified parts according to the instructions on MS3 online or the Workshop Manual:

CAUTION: Make sure to install all three (3) modified parts as a set. If not installed as a set, the seat warmer will not operate properly.

(Section 09-13 FRONT SEAT CUSHION TRIM REMOVAL/INSTALLATION).

(Section 09-13 FRONT SEAT BACK TRIM REMOVAL/INSTALLATION).

(Section 09-13 SEAT WARMER CONTROL UNIT REMOVAL/INSTALLATION).

3. Verify the repair.

PART(S) INFORMATION

New	Old	Description	Qty.	Notes
KA0K-88-11XB	KA0K-88-11XA	Heater / Pad (R), Front Seat Cushion	1	---
KA0G-88-13X	KA0K-88-13X	Heater / Pad (R), Front Seat Back	1	---
KAYG-88-092	KA0K-88-092	Coupler, Box	1	Service Part
<p>NOTE: The three (3) new parts listed above are NOT interchangeable with the old parts. The new parts must be installed as a set. If the old and new parts are mixed, the seat warmer will not operate properly and there is also a possibility the seat weight sensor durability could be affected.</p>				
KD45-88-1G5-02	---	Knob (R), Knuckle	1	"R" part

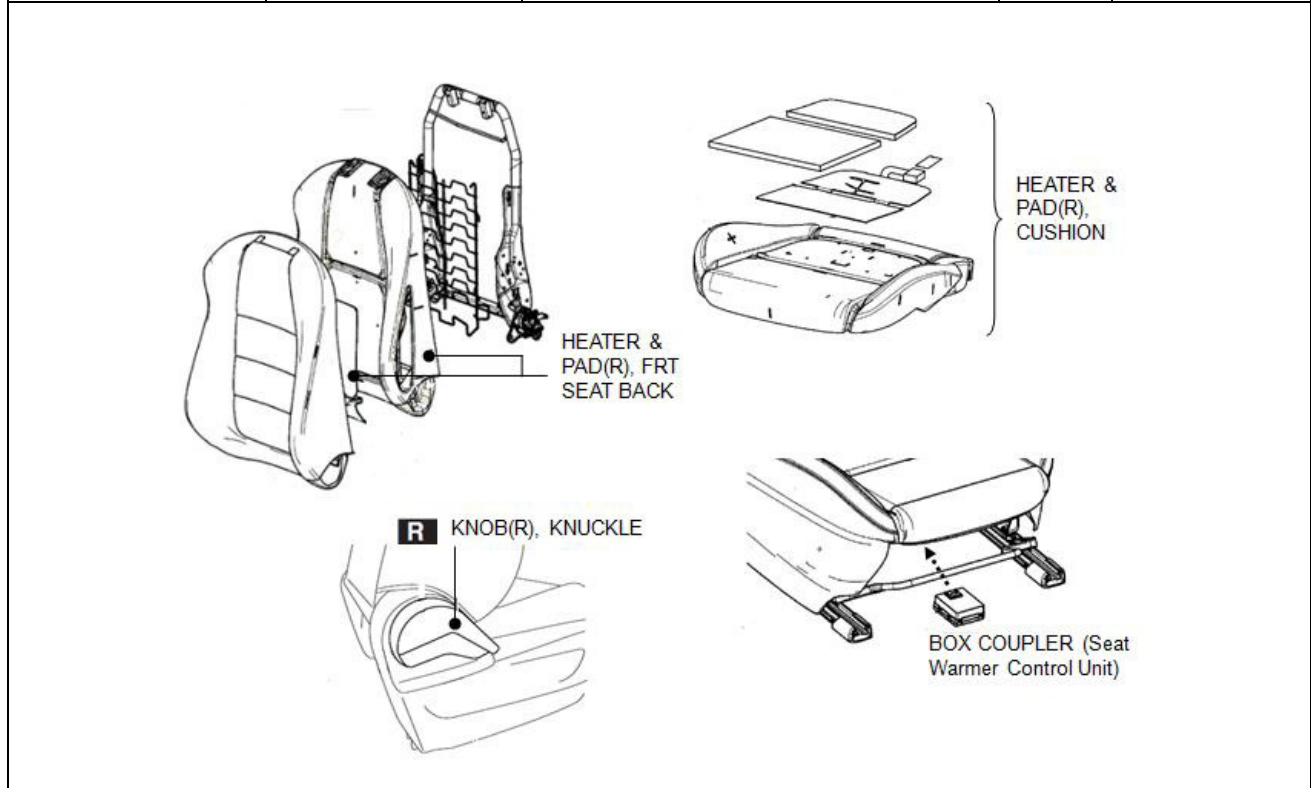

NOTE: The following caution label is attached to the top of the modified Coupler, Box (KAYG-88-092) service part. The label indicates that the same modified service part should be used again, in the event of a future parts replacement.

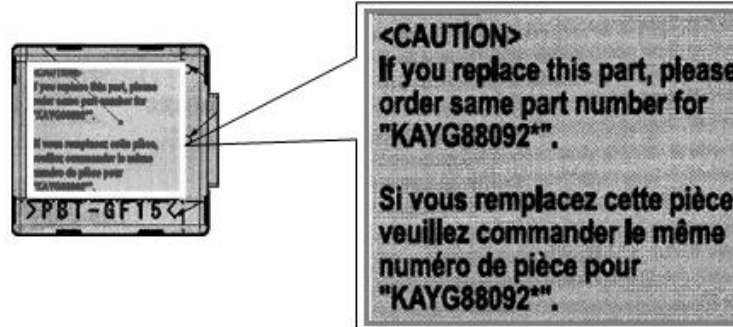

WARRANTY INFORMATION

NOTE:

- This warranty information applies only to verified customer complaints on vehicles eligible for warranty repair.
- This repair will be covered under Mazda's New Vehicle Limited Warranty term.
- Additional diagnostic time cannot be claimed for this repair.

Warranty Type	A
Symptom Code	59
Damage Code	9W
Part Number Main Cause	KA0K-88-11XB
Quantity	1
Operation Number / Labor Hours:	XXM37XRX / 2.0 Hrs.

NOTE: This bulletin only applies to vehicles equipped with cloth seats, not leather.