

Technical Service Bulletin



20 Noises from fuel tank area

20 16 77 2035591/3 August 31, 2016. Supersedes Technical Service Bulletin Group 20 number 14-42 dated December 19, 2014 for reasons listed below.

Model(s)	Year	VIN Range	Vehicle-Specific Equipment
Q7	2011 - 2014	All	3.0 TFSI

Condition

REVISION HISTORY		
Revision	Date	Purpose
3	-	Revised <i>Required Parts and Tools</i> (Added seal ring)
2	12/19/2014	Revised title Revised <i>Warranty</i> (Changed Service Number)
1	12/13/2013	Initial publication

Customer reports hearing noises from the rear of vehicle or from fuel tank area.

Technical Background

Normal fuel system pulsation can cause slight vibrations in the pressure regulator on the flange located on the right side of the fuel tank. This pulsation also causes the long, curved fuel lines (Figure 1) to vibrate and make a jarring noise in the tank.



Figure 1. The long, curved fuel lines that run across the fuel tank from right to left.

Production Solution

Long, curved fuel lines fastened with a tie wrap.

Service

1. Open the flange lock on the right side of the fuel tank according to the instructions in *Repair Manual >> Engine >> Fuel Supply System >> 20 Fuel Supply >> Removal and Installation*.
2. Slightly pull the right locking flange with seal out of the fuel tank.
3. Disconnect two electrical connectors on the underside of the right locking flange (Figure 2).

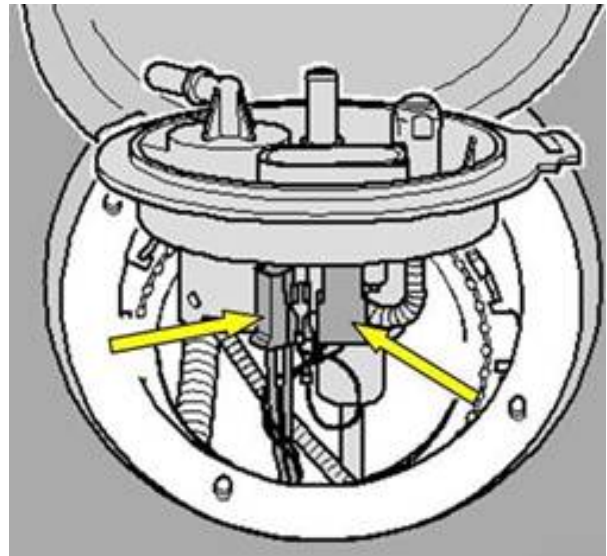

Figure 2. Two electrical connectors on the right locking flange to be disconnected.

4. Disconnect fuel line (Figure 3) by pressing release button.

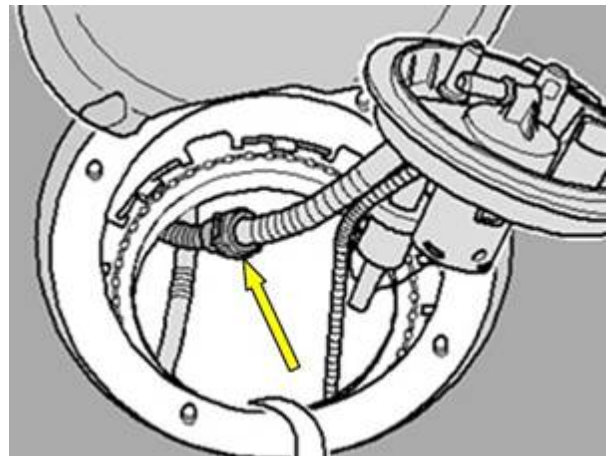

Figure 3. Fuel line connected to the locking flange.

5. Disconnect the two black corrugated lines leading from the suction jets and move them to the left in order to create space for working on other fuel lines (Figure 4).

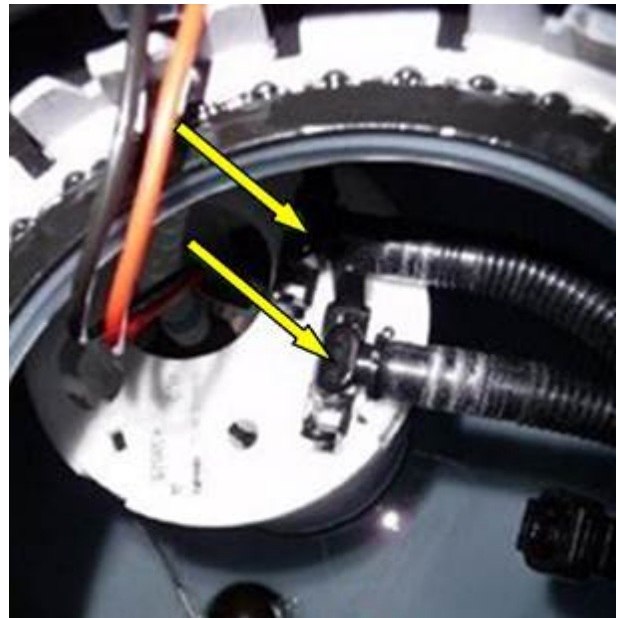

Figure 4. Black corrugated lines leading from the suction jets to be moved.

6. Pull the curved fuel lines (Figure 5) as far to the right of the vehicle as possible without using force.

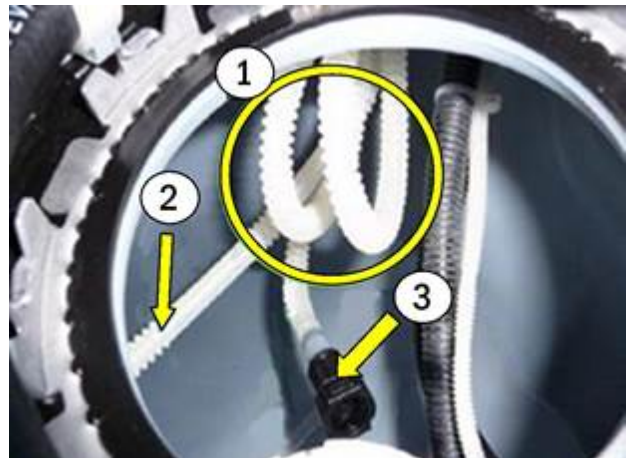

Figure 5. Curved fuel lines (1), fuel supply pipe (2), and fuel line.

7. Tie the curved fuel lines, fuels supply pipe, and fuel line together with a tie wrap (Figure 6).

The tie wrap must be close to the lower section of the curve of the curved fuel lines to prevent any contact with the suction jet pipes.



Figure 6. Curved fuel lines, fuels supply pipe, and fuel line tied together with tie wrap.

8. Refit the two black corrugated lines leading from the suction jets. Reconnect the rest of the lines and reconnect the two electric connectors to the flange.
Reinstall the flange according to the instructions in Elsa, and ensure that the flange seal is positioned correctly.

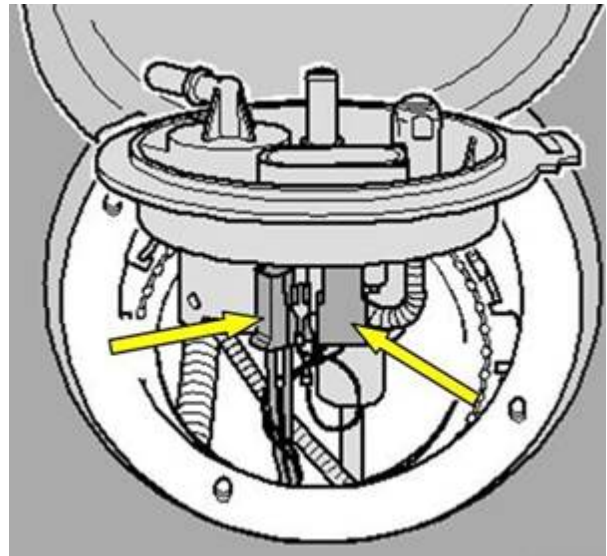

Figure 7. Two electrical connectors on the right locking flange to be reconnected.

Technical Service Bulletin



Warranty

Claim Type:	<ul style="list-style-type: none">• 110 up to 48 Months/50,000 Miles• G10 for CPO Covered Vehicles – Verify Owner• If vehicle is outside any warranty, this Technical Service Bulletin is informational only.		
Service Number:	2015		
Damage Code:	0020		
Labor Operations:	Loosen and attach fuel pump	2066 0999	190 TU
	Attach fuel pump/pipe	2066 1399	10 TU
Diagnostic Time:	GFF	No allowance	0 TU
	Road test prior to service procedure	No allowance	0 TU
	Road test after service procedure	No allowance	0 TU
	Technical diagnosis at dealer's discretion (Refer to Section 2.2.1.2 and Audi Warranty Online for DADP allowance details)		
Claim Comment:	As per TSB #2035591/3		

Required Parts and Tools

Part Number	Part Description	Quantity
See ETKA	Seal Ring	1
N 90937702	Tie wrap	1

Additional Information

All parts and service references provided in this TSB (2035591) are subject to change and/or removal. Always check with your Parts Department and service manuals for the latest information.