

© 2016 Mazda Motor of America, Inc.

Subject: RATTLE / CHATTER TYPE NOISE FROM A/C VENTS WHEN DRIVING ON ROUGH ROAD SURFACE	Bulletin No: 09-028/16
	Last Issued: 04/29/2016

APPLICABLE MODEL(S)/VINS

2016 CX-3 vehicles with VINs lower than JM1 DK ***** 109815 (produced before July 14, 2015)

DESCRIPTION

Some vehicles may exhibit a rattle/chatter type noise from the A/C vents when driving on an uneven/rough road surface.



Customers having this concern should have their vehicle repaired using the following repair procedure.

REPAIR PROCEDURE

1. Verify customer concern.
2. Remove the affected ventilator grille(s) (A/C vents). Refer to MS3 online "VENTILATOR GRILLE REMOVAL/INSTALLATION".
3. Cut the foam tape from the Noise Repair Kit (P/N TA01-76-100) to the following shapes.

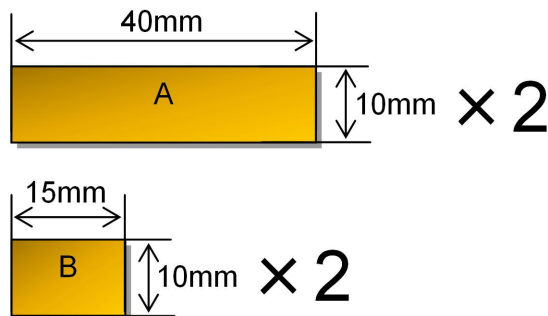

CONSUMER NOTICE: The information and instructions in this bulletin are intended for use by skilled technicians. Mazda technicians utilize the proper tools/equipment and take training to correctly and safely maintain Mazda vehicles. These instructions should not be performed by "do-it-yourselfers." Customers should not assume this bulletin applies to their vehicle or that their vehicle will develop the described concern. To determine if the information applies, customers should contact their nearest authorized Mazda dealership. Mazda North American Operations reserves the right to alter the specifications and contents of this bulletin without obligation or advance notice. All rights reserved. No part of this bulletin may be reproduced in any form or by any means, electronic or mechanical---including photocopying and recording and the use of any kind of information storage and retrieval system ---without permission in writing.

4. Apply the foam tape from the previous step to the following positions of the dashboard.

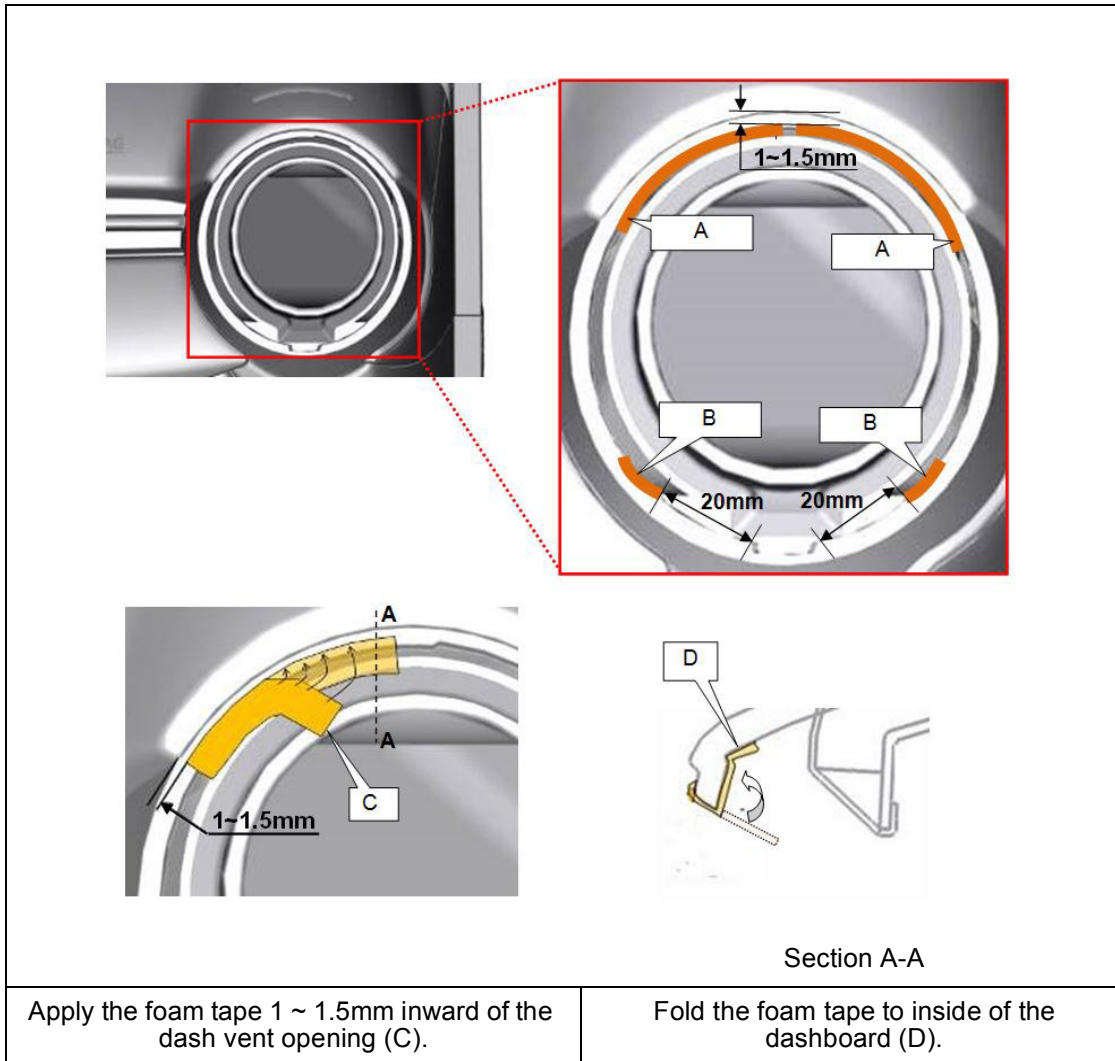

5. Install new ventilator grille(s). Refer to MS3 online “VENTILATOR GRILLE REMOVAL/INSTALLATION”.
6. Verify repair.

PART(S) INFORMATION

Part Number	Description	Qty.	Notes
D10A-64-730 0A	GRILLE, VENTILATION	1	Interior Color: DX0 (DW4) SILVER BLACK
D10C-64-730 0C	GRILLE, VENTILATION	1	Interior Color: DX1 (DW5) RED/BLACK
D10A-64-730 24	GRILLE, VENTILATION	1	Interior Color: DW9 (DW3) BLACK WHITE
TA01-76-100	NOISE REPAIR KIT	1	Repairs 24 ventilator grilles

NOTE: Use GEPC to look up the correct part number by VIN.

WARRANTY INFORMATION

NOTE:

- This warranty information applies only to verified customer complaints on vehicles eligible for warranty repair.
- This repair will be covered under Mazda's New Vehicle Limited Warranty term.
- Additional diagnostic time cannot be claimed for this repair.

Warranty Type	A		
Symptom Code	82		
Damage Code	9C		
Part Number Main Cause	**** 60 400 (PANEL, INSTRUMENT)		
Quantity	0		
Related Part Number	**** 64 730 ** (GRILLE, VENTILATION)		
Quantity	1	2	3
Operation Number / Labor Hours:	XXM2RARX / 0.3 Hrs.	XXM2RBRX / 0.4 Hrs.	XXM2RCRX / 0.5 Hrs.
	Repair and replace 1 ventilator grille	Repair and replace 2 ventilator grilles	Repair and replace all 3 ventilator grilles

NOTE: Claim the Noise Repair Kit (P/N TA01-76-100) as a Related Part. (repairs 24 ventilator grilles)