

Rear Differential Coupling Growl Noise

Service Category Drivetrain

Section Axle/Differential

Market USA

Toyota Supports
 ASE Certification 

Applicability

YEAR(S)	MODEL(S)	ADDITIONAL INFORMATION
2006 – 2012	RAV4	Drive Type(s): 4WD Transmission(s): 5AT, 4AT

REVISION NOTICE

May 2, 2016 Rev1:

- The Parts Information section has been updated.

Any previous printed versions of this bulletin should be discarded.

Introduction

Some 2006 – 2012 model year 4WD RAV4 vehicles may exhibit a growl type noise from the rear differential coupling when driving as a result of contamination to the front bearing. Follow the procedure in this bulletin to address this condition.

Production Change Information

This bulletin applies to vehicles produced **BEFORE** the Production Change Effective VINs shown below.

MODEL	DRIVETRAIN	ENGINE	PLANT*	PRODUCTION CHANGE EFFECTIVE VIN**
RAV4	4WD	2GR-FE	TMMC	2T3#K4DV#CW086571
		2AR-FE		2T3#F4DV#CW249854
		2GR-FE	Tahara	JTM#K4DV#C5109638
		2AR-FE		JTM#F4DV#C5057661
		2GR-FE	Shokki	JTM#K4DV#CD019399
		2AR-FE		JTM#F4DV#CD045856

* Plant Code (11th digit): W = TMMC, 5 = Tahara, D = Shokki.

** For detailed information on VINs, please reference the [2012 VIN Decoder Chart](#) found on the Technical Information System (TIS), under *Reference Information: Technician Group*.

Rear Differential Coupling Growl Noise

Warranty Information

OP CODE	DESCRIPTION	TIME	OFP	T1	T2
DL1300	Inspect and Replace Rear Differential Coupling Only	2.0	41303-42020 41303-42021 41303-42022	91	99
DL1301	Inspect and Repair Rear Differential Coupling	3.2	41302-42050		

APPLICABLE WARRANTY

- This repair is covered under the Toyota Powertrain Warranty. This warranty is in effect for 60 months or 60,000 miles, whichever occurs first, from the vehicle's in-service date.
- Warranty application is limited to occurrence of the specified condition described in this bulletin.

Parts Information

PART NUMBER		PART NAME	QTY
PREVIOUS	NEW		
	41302-42050	Cover Sub-Assy	1
	90304-94005	Dust Seal	1
	90179-08197	Nut	2
	41252-42020	Deflector	1
	41252-42013		1
	12157-10010	Drain/Fill Plug Gasket	2
41303-42020 41303-42021 41303-42022	41303-42023	Coupling Sub-Assy	1

NOTE

- When ordering Deflector be sure to order the correct part number based on original deflector shape as shown below.
- The Linear Solenoid Yoke of Coupling Sub-Assy PN 41303-42023 has 2 mounting holes while original has 3. This is by design.

Rear Differential Coupling Growl Noise

Parts Information (Continued)

Figure 1. For This Deflector Type, Use P/N 41252-42020



Figure 2. For This Deflector Type, Use P/N 41252-42013



Required Tools & Equipment

REQUIRED MATERIAL	QUANTITY
FIPG Sealant: Three Bond 1281, or Equivalent	As Needed
Gear Oil*	0.48 – 0.58 U.S. qts, 0.40 – 0.48 Imp. qts (0.45 – 0.55 liters)

* For detailed information on Gear Oil, please reference the [2006-2009 MY Fluid Specifications](#) / [2010-2013 MY Fluid Specifications](#) charts found on TIS, under *Reference Information: Technician Group*.

SPECIAL SERVICE TOOLS (SST)	PART NUMBER	QTY
Replacer Set 2** (Replacer 89)	09950-60020-01 (09951-00890-01)	1
Crankshaft Rear Oil Seal Replacer**	09223-15030	1
Oil Seal and Bearing Replacer**	09518-36030-01	1
Handle Set**	09950-70010	1
Rear Axle Shaft Bearing Remover**	09527-10011-01	1
Universal Puller Set "B"*** (Hanger 150) (Slide Arm) (Claw No. 1) (Hanger 200) (Holder) (Center Bolt 200)	09950-40011 (09951-04010) (09952-04010) (09955-04011) (09951-04020) (09958-04011) (09953-04030)	1

** Essential SST.

Rear Differential Coupling Growl Noise

Required Tools & Equipment (Continued)

NOTE

Additional SSTs may be ordered by calling 1-800-933-8335.

REQUIRED EQUIPMENT	SUPPLIER	PART NUMBER	QTY
ChassisEAR™ (or equivalent)	ADE	JSPSM06606 (JS Products)	1

NOTE

- A mechanic's stethoscope or similar tool may be used in place of ChassisEAR™.
- ChassisEAR™ may be ordered by calling Approved Dealer Equipment (ADE) at 1-800-368-6787.

Rear Differential Coupling Growl Noise

Repair Procedure Overview

- Confirm the condition.
- Remove rear differential coupling.
- Inspect rear differential coupling assembly.
- Replace or rebuild rear differential coupling assembly.
- Confirm repair.

Repair Procedure

1. Confirm the condition.

Is there a growl type noise coming from the rear of the vehicle when driving?

- **YES** — Continue to step 2.
- **NO** — This bulletin does NOT apply. Continue diagnosis using the applicable Repair Manual.

2. Install ChassisEAR™ and test drive, or use a stethoscope with the vehicle on a lift and confirm the noise is loudest from the rear differential coupling assembly.

Is the noise loudest from the rear differential coupling?

- **YES** — Continue to step 3.
- **NO** — This bulletin does NOT apply. Continue diagnosis using the applicable Repair Manual.

3. Remove the rear differential coupling.

- A. Drain rear differential fluid.

Drain Plug Torque: 39 N*m (398 kgf*cm, 29 ft*lbf)

- B. Remove the rear propeller shaft.

Refer to the Technical Information System (TIS), applicable model and model year Repair Manual:

- [2006](#) / [2007](#) / [2008](#) / [2009](#) / [2010](#) / [2011](#) / [2012](#) RAV4:
Drivetrain – Drive Shaft/Propeller Shaft – “Propeller Shaft: Propeller Shaft Assembly: Removal”

Rear Differential Coupling Growl Noise

Repair Procedure (Continued)

- C. Remove the 4 stud bolts.

Using a double nut configuration, with new nuts, remove the 4 studs from the rear differential coupling.

HINT

Use a wooden or plastic hammer/mallet handle to protect the stud threads and hold the coupling when loosening the stud bolts. Once the stud bolt is removed, loosely thread the stud bolt back into the coupling to allow for removal of the other stud bolts.

Figure 3.



Figure 4.



- D. Support the rear differential with a floor jack.

- E. Remove the 4 bolts from the rear differential No. 1 and No. 2 supports to allow clearance to remove the differential coupling.

Figure 5.

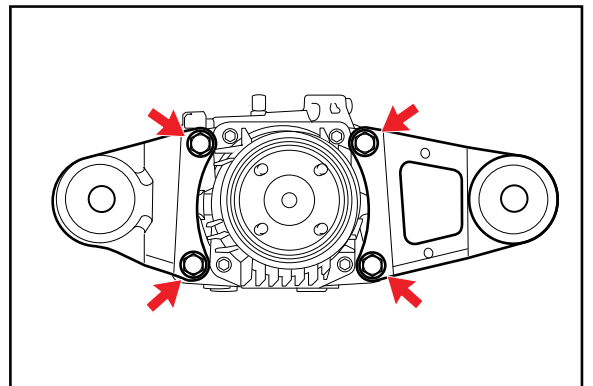

- F. Remove the 4 bolts and differential coupling assembly.

Rear Differential Coupling Growl Noise

Repair Procedure (Continued)

4. Inspect the rear differential coupling assembly.

NOTE

Use the following criteria to determine if the rear differential coupling will be rebuilt or replaced.

If the rear differential coupling body assembly shows any of the issues noted below, the rear differential coupling assembly **CANNOT** be rebuilt and must be replaced as an assembly.

By comparing the part to Figures 6-10 below, can the rear differential coupling be rebuilt

- **YES** — Continue to step 6. Remove the rear differential coupling cover assembly.
- **NO** — Continue to step 5. Replace the rear differential coupling assembly.

Figure 6. Damage Where Propeller Shaft Contacts Coupling Body



Figure 7. Excessive Rust/Corrosion Buildup on Top of Coupling Body



Figure 8. Rust/Corrosion on Inside of Coupling Body



Figure 9. Excessive Rust/Corrosion Buildup on Edge of Coupling Body



Rear Differential Coupling Growl Noise

Repair Procedure (Continued)

Figure 10. Rear Differential Coupler Body Is Dark in Color

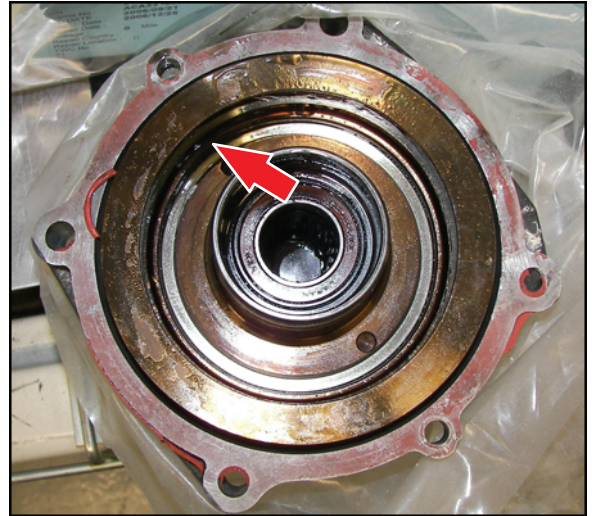

5. Replace the rear differential coupling assembly.
 - A. Install the coupling shim (use same shim from disassembly).
 - B. Install the coupling conical spring washer to the rear differential carrier.

Figure 11.

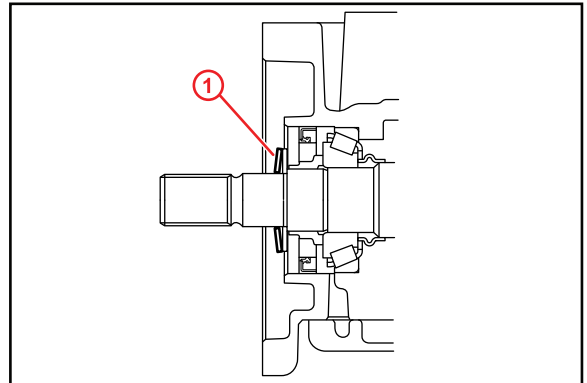

1	Transmission Coupling Conical Spring Washer
----------	--

Rear Differential Coupling Growl Noise

Repair Procedure (Continued)

- C. Clean the rear differential coupling and rear differential seal surfaces, then apply seal packing in a continuous line, 2 – 3 mm (0.08 – 0.12 in.) in diameter, to the rear differential coupling.

FIPG Sealant: Three Bond 1281, or equivalent

NOTE

Install the rear differential coupling within 3 minutes of applying seal packing.

Figure 12.

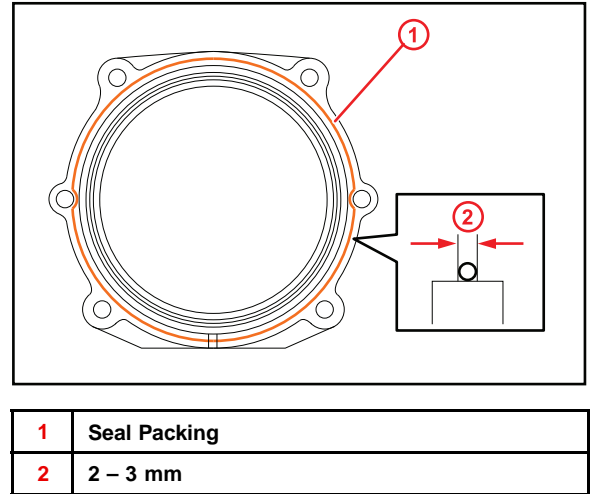

- D. Install the coupling to the rear differential with 4 bolts.

Torque: 19.6 N*m (200 kgf*cm, 14 ft*lbf)

- E. Install the 4 bolts from the rear differential No. 1 and No. 2 supports.

Torque: 55 N*m (561 kgf*cm, 41 ft*lbf)

Figure 13.

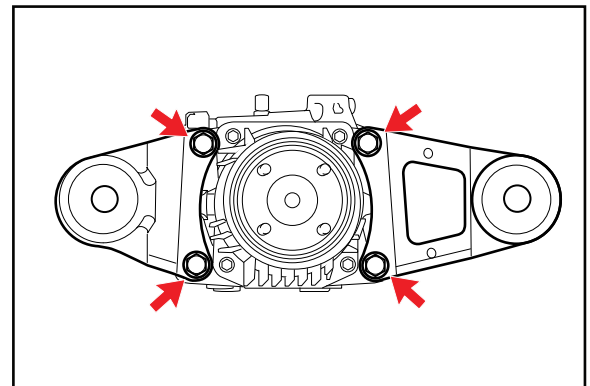

- F. Using a double nut configuration, install 4 stud bolts to the rear differential coupling.

- G. Fill rear differential assembly with oil.

Torque: 39 N*m (398 kgf*cm, 29 ft*lbf)

NOTICE

Be sure to clean off any oil that may have dripped onto the exhaust pipe during the oil fill procedure.

Rear Differential Coupling Growl Noise

Repair Procedure (Continued)

H. Install the rear propeller shaft.

Refer to TIS, applicable model and model year Repair Manual:

- [2006](#) / [2007](#) / [2008](#) / [2009](#) / [2010](#) / [2011](#) / [2012](#) RAV4:
Drivetrain – Drive Shaft/Propeller Shaft – “Propeller Shaft: Propeller Shaft Assembly: Installation”

I. Test drive the vehicle and confirm the repair.

6. Remove the rear differential coupling cover and bearing assembly.

A. Using a hydraulic press and the SST, place the rear differential coupling on the SST with only the cover in contact with the SST.

SST: 09527-10011-01

Figure 14.

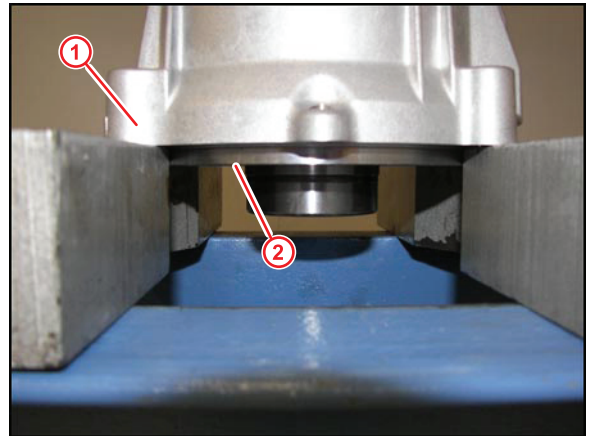

1	Rear Differential Coupling Cover
2	Rear Differential Coupling Body

Rear Differential Coupling Growl Noise

Repair Procedure (Continued)

- B. Using the SSTs, slowly press the rear differential coupling body out of the cover assembly.

SST: 09951-00890-01

SST: 09950-70010

CAUTION

Take care to support the rear differential coupling body as it is pressed out.

Figure 15.

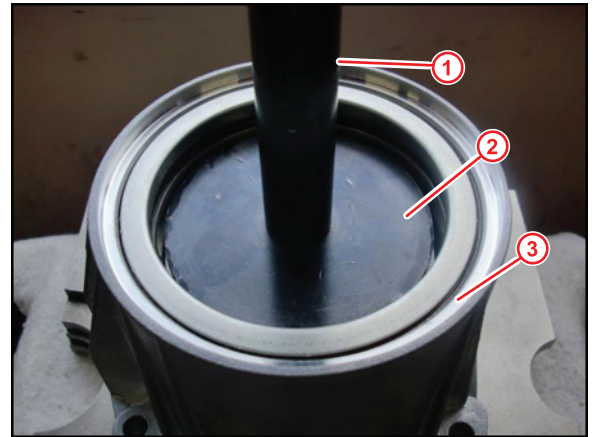

1	SST 09950-70010
2	SST 09951-00890-01
3	Rear Differential Coupling Cover

- C. If the bearing assembly stays on the rear differential coupling body, use the SSTs to remove the bearing.

SST: 09950-40011 (09951-04010, 09952-04010, 09955-04011, 09951-04020, 09958-04011, 09953-04030)

SST: 09951-00890-01

NOTE

If the bearing stayed inside the rear differential cover, proceed to step 7.

Figure 16.

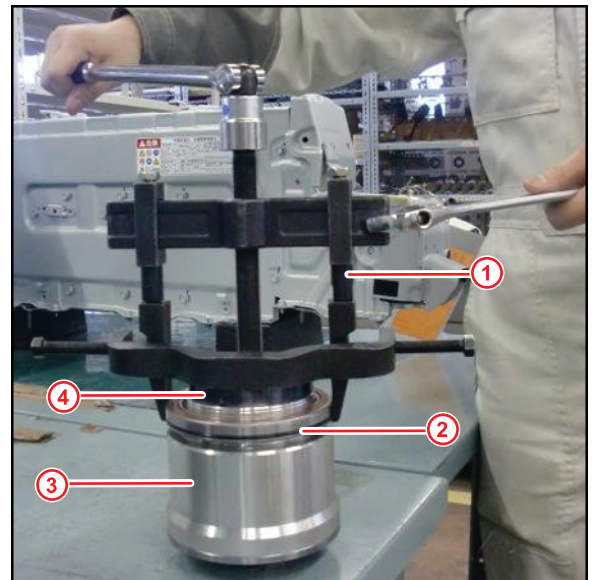

1	SST 09950-40011
2	Bearing
3	Rear Differential Coupling Body Assembly
4	SST 09951-00890-01

Rear Differential Coupling Growl Noise

Repair Procedure (Continued)

7. Inspect the rear differential coupling body bearing press surface.
 - A. If there is rust or corrosion from the yellow line or above, the coupling CAN be rebuilt.
 - B. If there is rust or corrosion below the yellow line, the coupling CANNOT be rebuilt. Replace the rear differential coupling assembly. Go to step 5.

See Figures 18 and 19 for general guidelines.

HINT

Some coupling bodies may have a slightly shorter bearing press surface, but all coupling bodies will have a machined center line (Red) that can be used to find the Yellow line.

Figure 17.

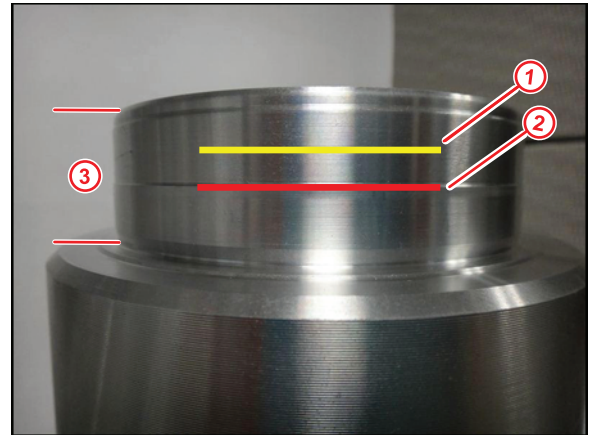

1	Yellow Line = Approximate Center Line Between Red Line and Top of Coupling Body
2	Red Line = Approximate Center Line of Bearing Press Surface (Machined Line)
3	Bearing Press Surface

Rear Differential Coupling Growl Noise

Repair Procedure (Continued)

Figure 18. Examples of Coupling Bodies that Are OK to Rebuild

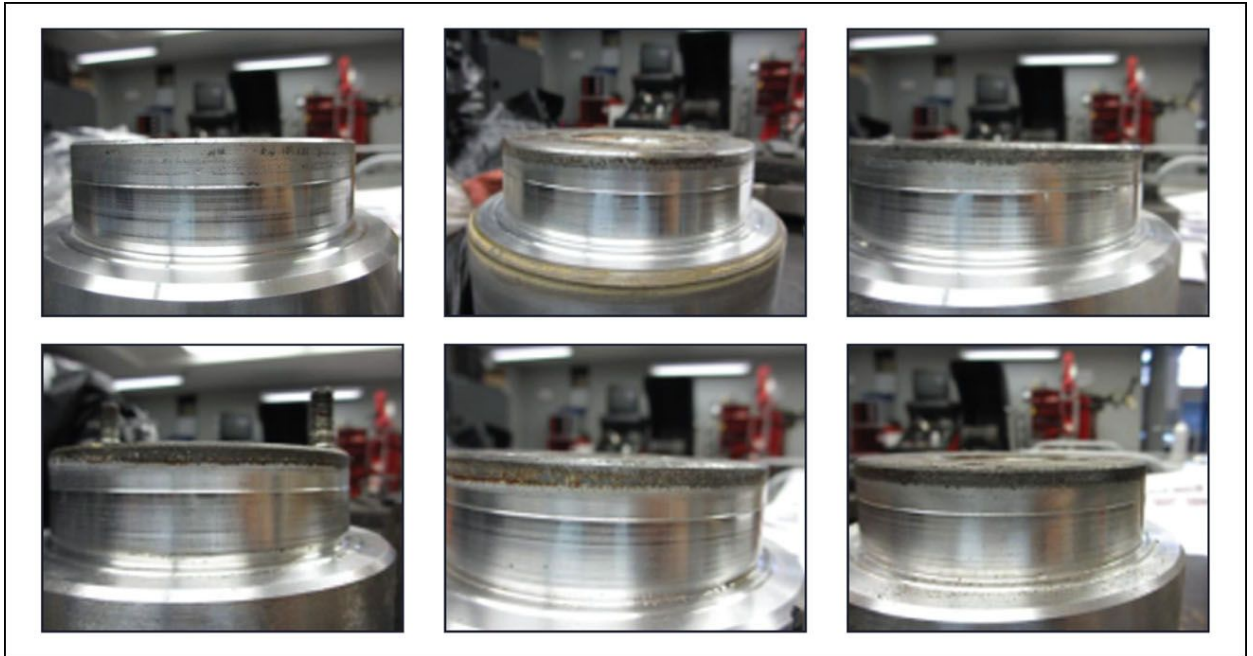
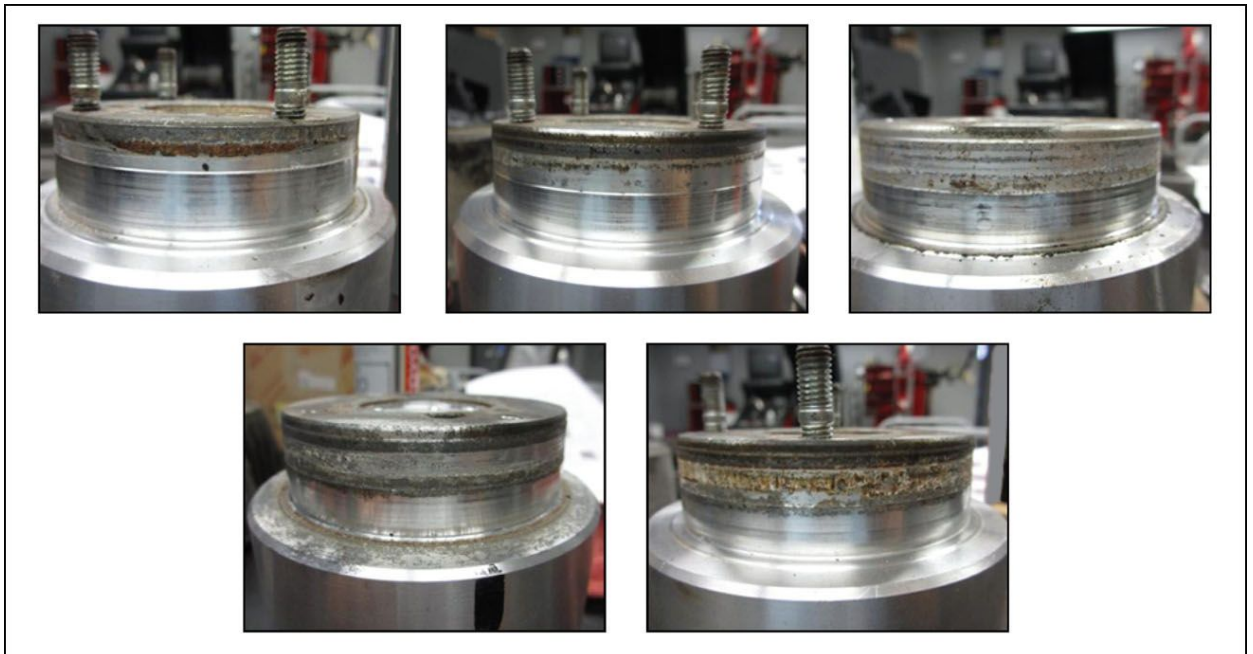

Figure 19. Examples of Coupling Bodies that CANNOT Be Rebuilt



Rear Differential Coupling Growl Noise

Repair Procedure (Continued)

- C. Based on the inspection criteria, can the rear differential coupling be rebuilt?
 - **YES** — Continue to step 8. Begin the rebuild process.
 - **NO** — Go to step 5 (page 7). Replace the rear differential coupling assembly.
- 8. Rebuild the rear differential coupling.
 - A. Clean the coupling body assembly, prior to assembly, to remove any loose debris.
 - B. Set the new coupling cover onto the coupling body and place the coupling body onto the SST.
SST: 09527-10011-01

NOTICE

- Be sure the SST is supporting the coupling body, NOT the coupling cover.
- Be sure coupling is sitting level on SST 09527-10011-01.

Figure 20.

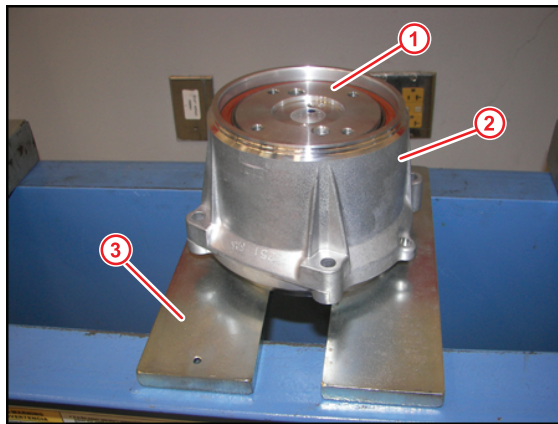

1	Coupling Body
2	New Coupling Cover with Bearing
3	SST

Figure 21.

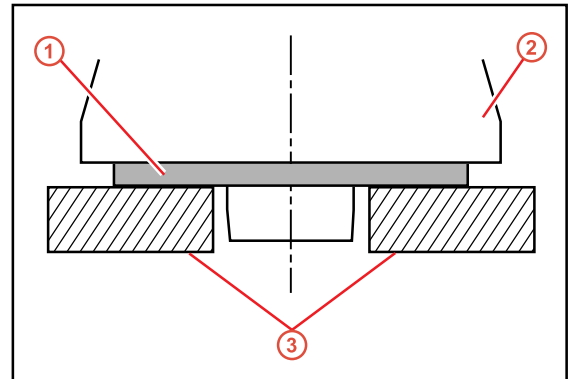

1	Coupling Body
2	Coupling Cover
3	SST

Rear Differential Coupling Growl Noise

Repair Procedure (Continued)

- C. Using a press and the SSTs, slowly press the new coupling cover with the bearing onto the coupling body.

SST: 09527-10011-01

SST: 09223-15030

SST: 09950-70010

Press the bearing and cover assembly onto the coupling body until the bearing is fully seated against the coupling body.

NOTE

Be sure the coupling body is level before pressing on the coupling cover with the bearing.

Figure 22.

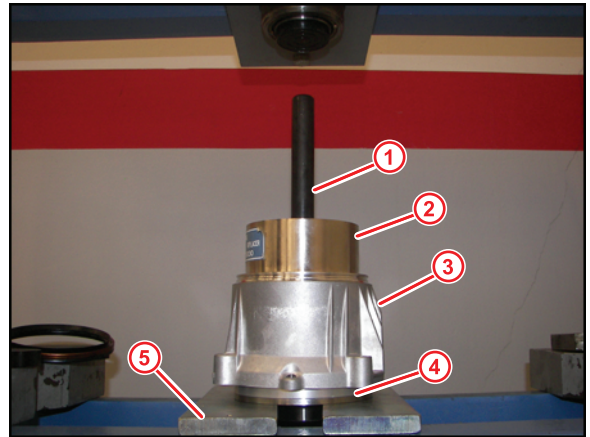

1	SST 09950-70010
2	SST 09223-15030
3	Coupling Cover Assembly
4	Coupling Body Assembly
5	SST 09527-10011-01

Rear Differential Coupling Growl Noise

Repair Procedure (Continued)

D. Install the dust seal.

- (1) Place the dust seal onto the coupling assembly as level as possible, and with the lip facing up as seen in Figure 23.

NOTICE

- Take caution NOT to touch the lip of the seal, or contaminate the lip with debris.
- Be sure the SST is supporting the coupling body, NOT the coupling cover.
- Be sure coupling is sitting level on SST 09527-10011-01.

Figure 23.

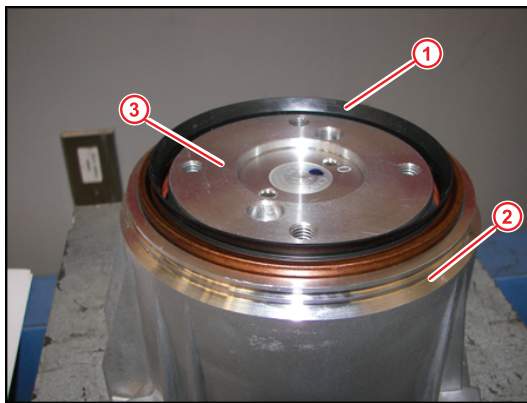

1	Dust Seal
2	Coupling Cover
3	Coupling Body

Figure 24.

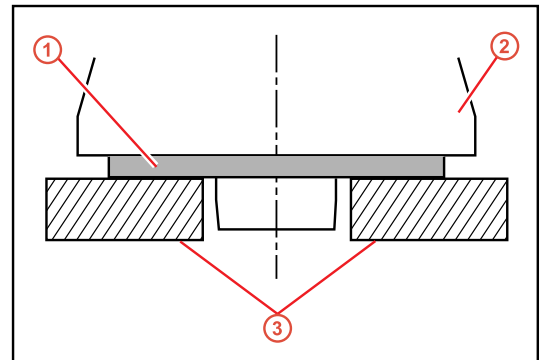

1	Coupling Body
2	Coupling Cover
3	SST

Rear Differential Coupling Growl Noise

Repair Procedure (Continued)

- (2) Place the SSTs onto the dust seal flat surface.

SST: 09518-36030-01

SST: 09950-70010

NOTICE

Be sure that SST 09518-36030-01 is clean of debris that can contaminate the lip seal. Confirm the lip of the dust seal is NOT pinched and goes on the inside of the SST.

Figure 25.

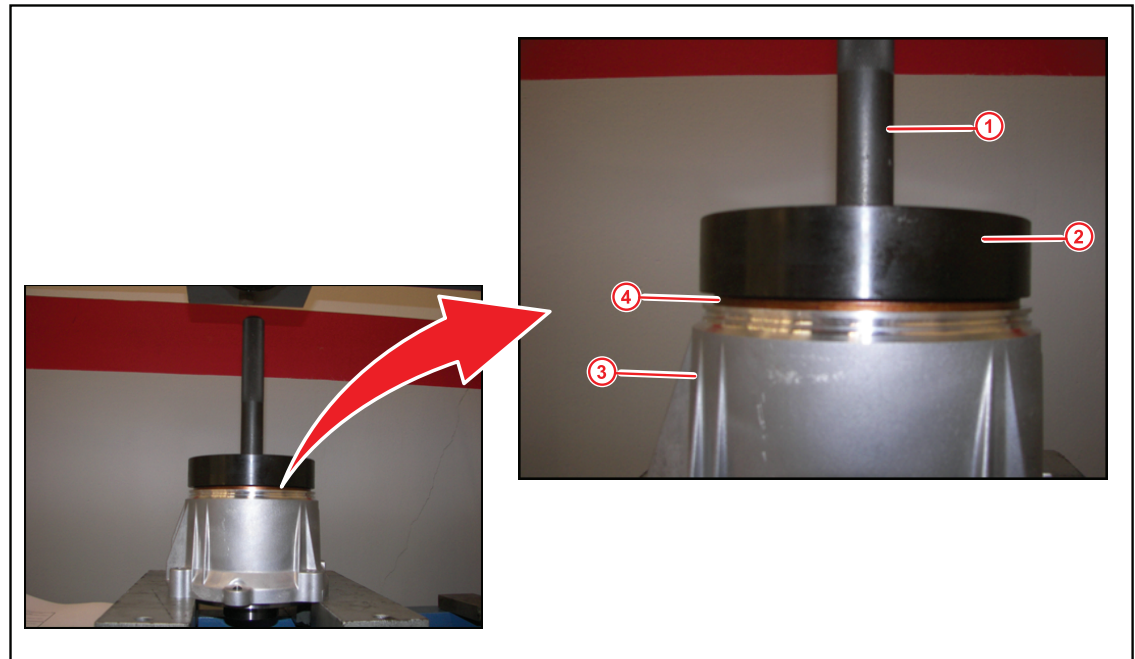

1	SST 09950-70010
2	SST 09518-36030-01

3	Coupling
4	Dust Seal

Rear Differential Coupling Growl Noise

Repair Procedure (Continued)

- (3) Slowly press the new dust seal into position until the edge of the seal ring is flush with the coupling cover.

NOTICE

- Ensure the coupling body is in contact with SST 09527-10011-01, NOT the coupling cover, before pressing on the dust seal.
- Be sure coupling is sitting level on SST 09527-10011-01.

Figure 26.

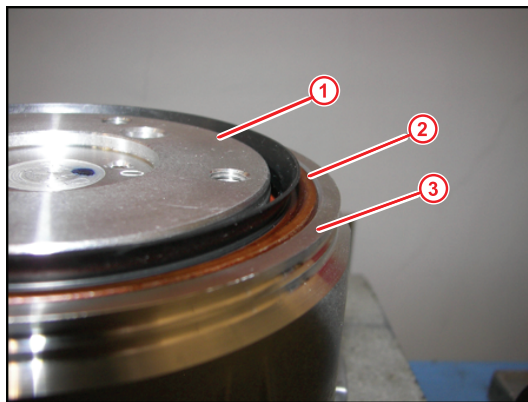

1	Coupling Body
2	Dust Seal
3	Coupling Cover

Figure 27.

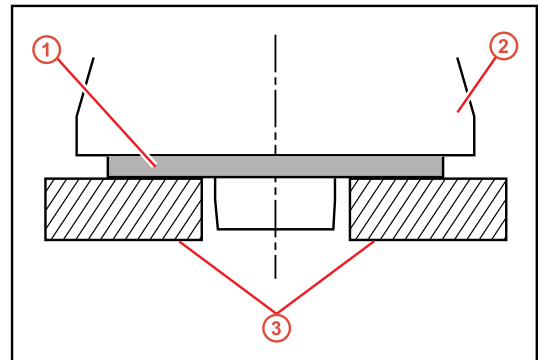

1	Coupling Body
2	Coupling Cover
3	SST

Rear Differential Coupling Growl Noise

Repair Procedure (Continued)

E. Install the deflector.

NOTE

Confirm the correct deflector is installed based on original deflector shape.

Figure 28. Use P/N 41252-42020



Figure 29. Use P/N 41252-42013



(1) Set the deflector onto the dust seal so that it is level.

NOTICE

Be sure the SST is supporting the coupling body, NOT the coupling cover.

Figure 30.

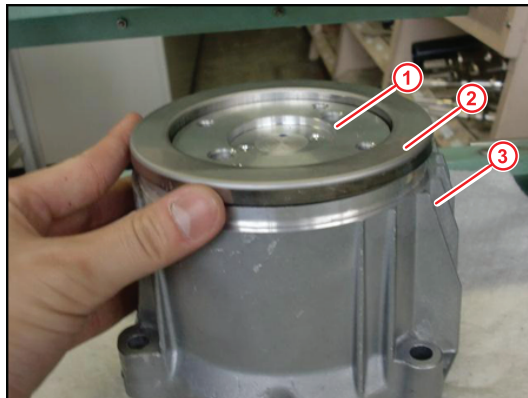

1	Coupling Body
2	Deflector
3	Coupling Cover

Figure 31.

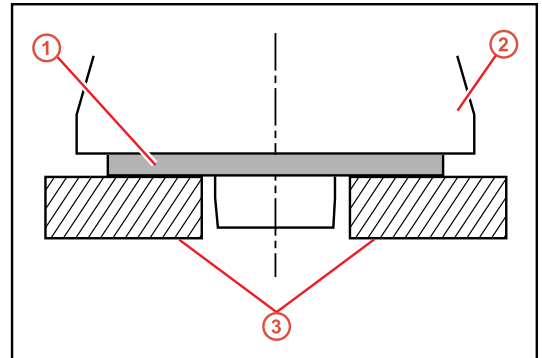

1	Coupling Body
2	Coupling Cover
3	SST

Rear Differential Coupling Growl Noise

Repair Procedure (Continued)

- (2) Using the SSTs, slowly press the deflector onto the coupling assembly. The deflector should be even with the coupling body.

SST: 09950-70010

SST: 09518-36030-01

NOTICE

Ensure the coupling body is in contact with SST 09527-10011-01, NOT the coupling cover, before pressing on the deflector.

Figure 32.

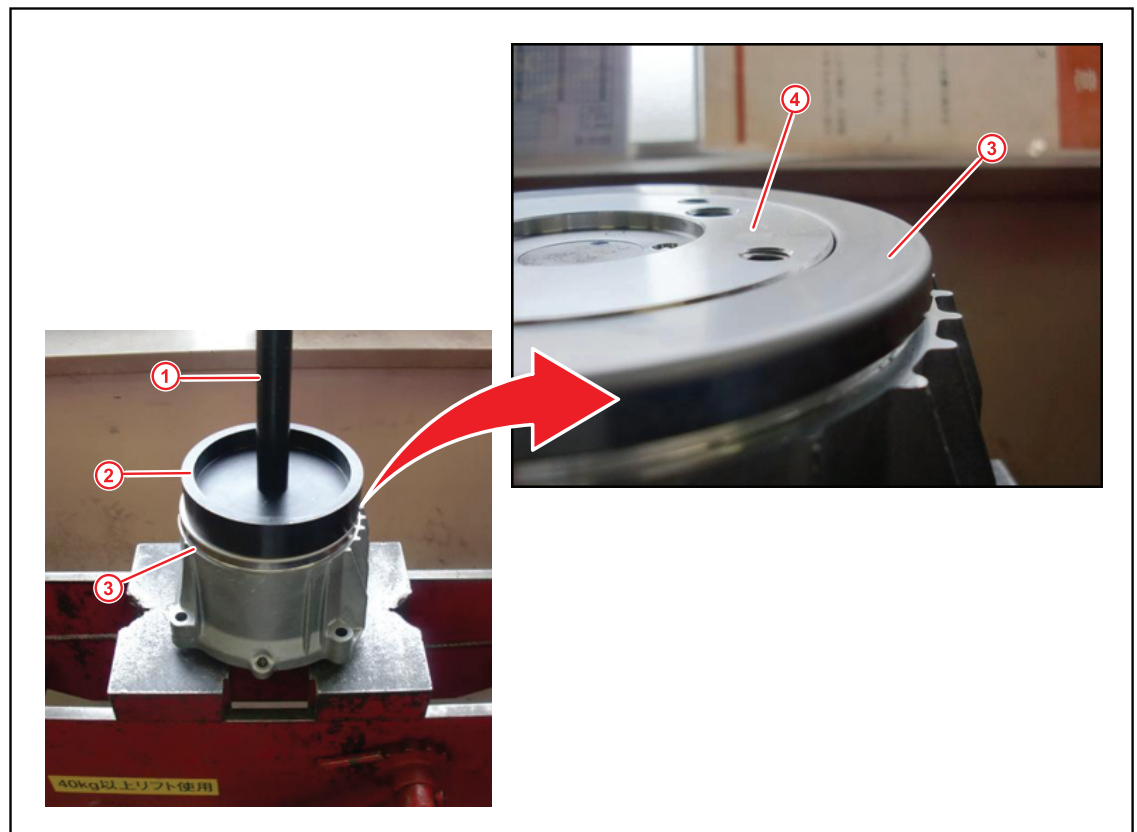

1	SST 09950-70010
2	SST 09518-36030-01

3	Deflector
4	Coupling Body

- F. Go back to step 5 (page 7) to reinstall the differential coupling assembly.