

Cruise Control Stalk Illumination Intermittent Operation

Service Category Vehicle Interior

Section Meter/Gauge/Display

Market USA

Toyota Supports
 ASE Certification 

Applicability

YEAR(S)	MODEL(S)	ADDITIONAL INFORMATION
2014 - 2016	Sienna	

Introduction

Some 2014 – 2016 Sienna vehicles may exhibit an intermittent cruise control stalk illumination flicker condition. Please follow the Repair Procedure in this bulletin to address this condition.

Warranty Information

OP CODE	DESCRIPTION	TIME	OFF	T1	T2
EL1600	Cruise Illumination circuit wire install	0.7	45250-08043 45250-08053 45250-08033 45250-08060 45250-08080 45250-08090	87	41

APPLICABLE WARRANTY

- This repair is covered under the Toyota Basic Warranty. This warranty is in effect for 36 months or 36,000 miles, whichever occurs first, from the vehicle's in-service date.
- Warranty application is limited to occurrence of the specified condition described in this bulletin.

Cruise Control Stalk Illumination Intermittent Operation

Parts Information

PART NUMBER	PART NAME	QTY
82998-0E010 82998-08030 82998-08010 82998-08020	Terminal, Repair w/Wire	1

NOTE

- 12-pin spiral cable equipped vehicles have a heated steering wheel, order Part Numbers 82998-0E010 & 82998-08020.
- 10-pin spiral cables are used on Sienna without heated steering wheel, order Part Numbers 82998-08010 and 82998-08030.

Required Tools & Equipment

REQUIRED TOOLS & MATERIAL	QTY
Cable Tie	3

REQUIRED EQUIPMENT	SUPPLIER	PART NUMBER	QTY
Techstream 2.0*	ADE	TS2UNIT	1
Techstream Lite		TSLITEPDLR01	

SPECIAL SERVICE TOOLS (SST)	PART NUMBER	QTY
Plastic Pry Tool Set, or Equivalent	00002-06000-01	1
Plastic Emblem Removal Tool, or Equivalent	00002-06002-01	1
Plastic Panel Clip Removal Tool, or Equivalent	00002-06001-01	1

* Essential SST.

NOTE

- Only ONE of the Techstream units listed above is required.
- Software version 11.00.017 or later is required.
- Additional Techstream units may be ordered by calling Approved Dealer Equipment (ADE) at 1-800-368-6787.

Cruise Control Stalk Illumination Intermittent Operation

Repair Procedure

CAUTION

Some of these service operations affect the SRS airbag system. Read the precautionary notices concerning the SRS airbag system before servicing the steering wheel area.

[2014](#) / [2015](#) Sienna:

Vehicle Interior – Supplemental Restraint Systems – “Supplemental Restraint Systems: Airbag System: Precaution”

Refer to the Technical Information System (TIS), applicable model and model year Repair Manual:

- [2014](#) / [2015](#) Sienna:

Steering – Steering Column – “Steering Column: Steering System: Precaution”

1. Turn the steering wheel to provide clearance and remove the 2 screws in the lower steering column cover.

NOTE

The steering wheel should NOT be removed. Merely rotate it for appropriate clearance to remove screws in the steering column cover.

Figure 1.

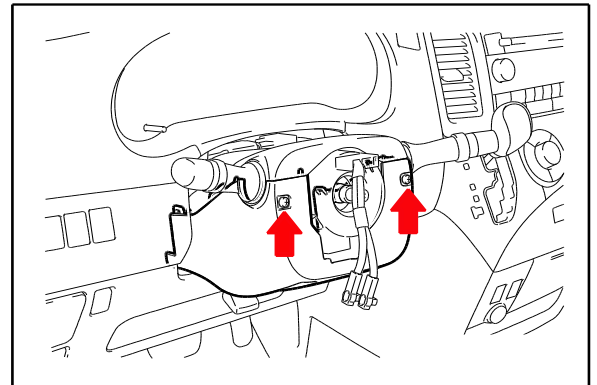

2. Turn the wheels so that they face straight ahead.

Cruise Control Stalk Illumination Intermittent Operation

Repair Procedure (Continued)

3. Disconnect the negative (–) battery terminal and remove the steering pad.

Refer to TIS, applicable model, and model year Repair Manual for instructions and cautions:

- [2014 / 2015](#) Sienna:
Vehicle Interior – Supplemental Restraint Systems – “Supplemental Restraint Systems: Steering Pad: Removal”

CAUTION

Wait at least 90 seconds after disconnecting the cable from the negative (–) battery terminal to disable the SRS system.

NOTICE

When disconnecting the battery cable, some systems need to be initialized after the cable is reconnected. To prevent data loss before disconnecting the battery, please be familiar with the following instructions:

- [2014 / 2015](#) Sienna:

General – Repair Instruction – “Introduction: Repair Instruction: Initialization”

Cruise Control Stalk Illumination Intermittent Operation

Repair Procedure (Continued)

4. Remove the lower steering column cover.
 - A. Push the right and left sides of the lower steering column cover and disengage the 4 claws.

Figure 2.

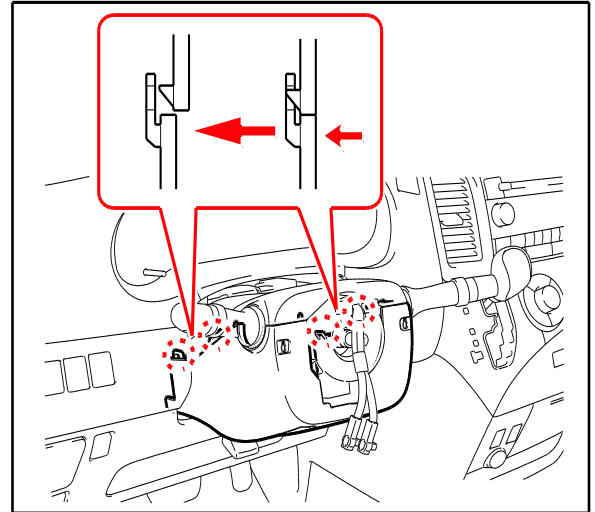

- B. Insert fingers into the opening of the tilt lever of the lower steering column cover to detach the claw.

Figure 3.

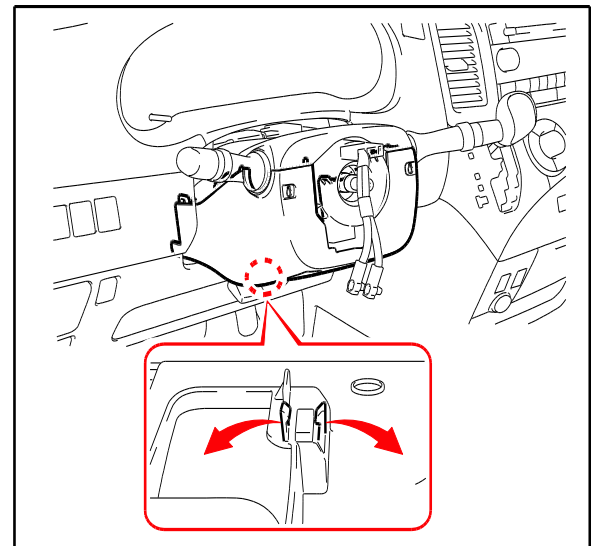

HINT

Spread the claw to disengage it.

Cruise Control Stalk Illumination Intermittent Operation

Repair Procedure (Continued)

5. Remove the upper steering column cover.
 - A. Disengage the claw.

Figure 4.

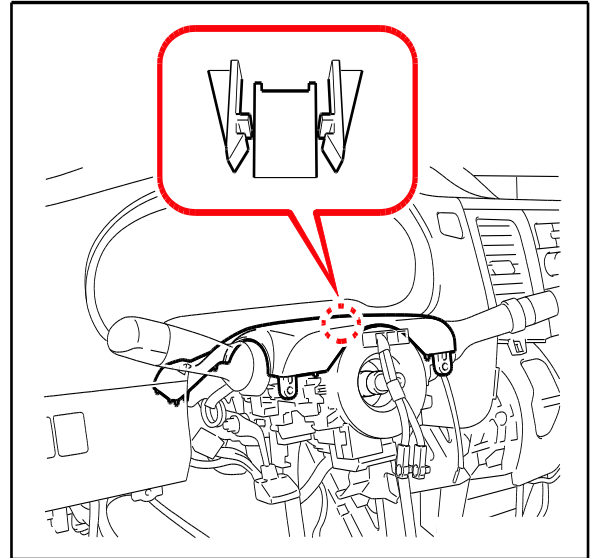

- B. Disengage the 4 clips and 2 guides to remove the upper steering column cover.

Figure 5.

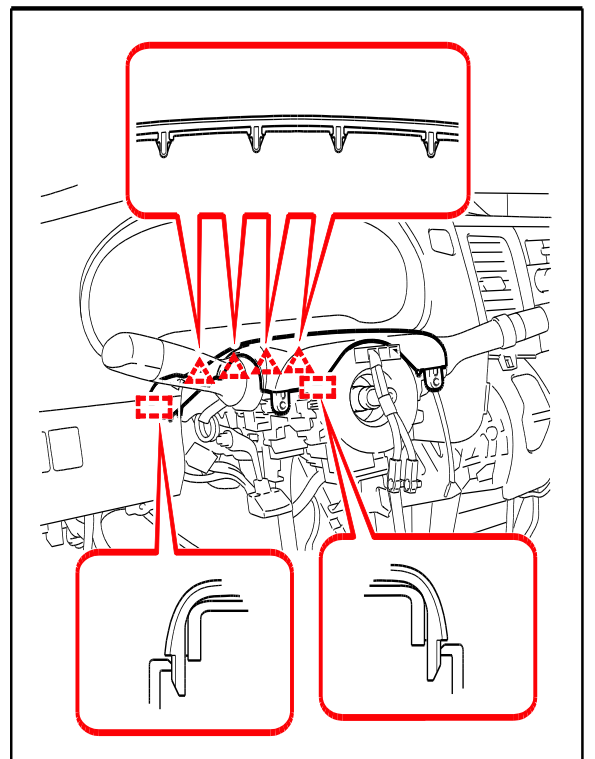

Cruise Control Stalk Illumination Intermittent Operation

Repair Procedure (Continued)

6. Disconnect switch harness connector Z2 (10-pin connector), or Z8 (12-pin connector) from the spiral cable at the steering wheel above the steering column shaft nut and cruise control stalk.

Figure 6. Z2/Z8 Location

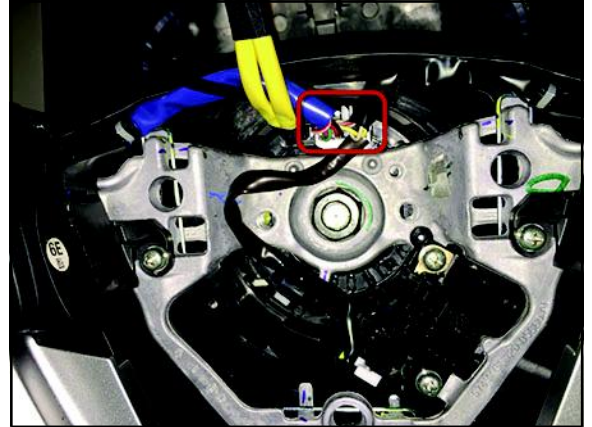

7. Raise the connector terminal locking tab by gently prying upward.

Figure 7.

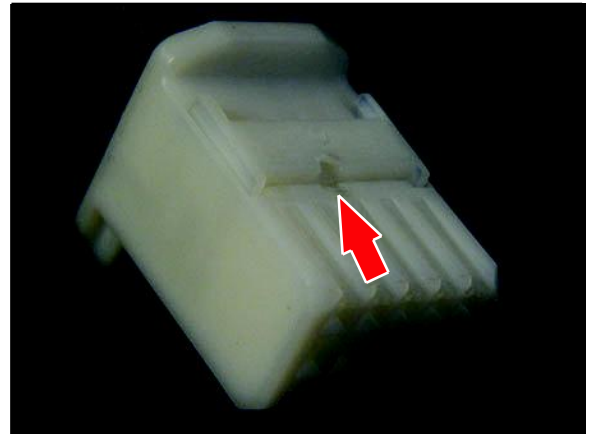

NOTE

- Locking tab does **NOT** come completely off.
- Connector color may not match illustration — verify colors as seen in Figures 8, 9, 10, 16, 17, and 18.

Cruise Control Stalk Illumination Intermittent Operation

Repair Procedure (Continued)

8. Insert correct pin terminal into connector, according to the year below:
 - A. For 2014 model year Sienna, 10-pin connector, insert PN 82998-08010 into cavity 7 of white connector Z2 (PN 90980-12361).

Figure 8.

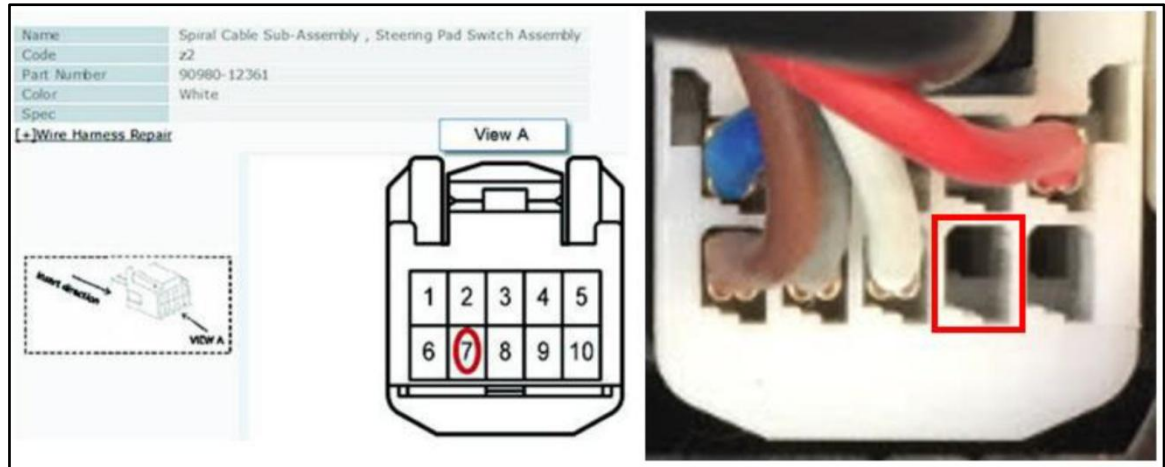

- B. For 2015 or later model year Sienna vehicles equipped with heated steering wheel (12-pin connector), insert PN 82998-0E010 pin terminal into cavity 12 of connector Z8.

Figure 9.

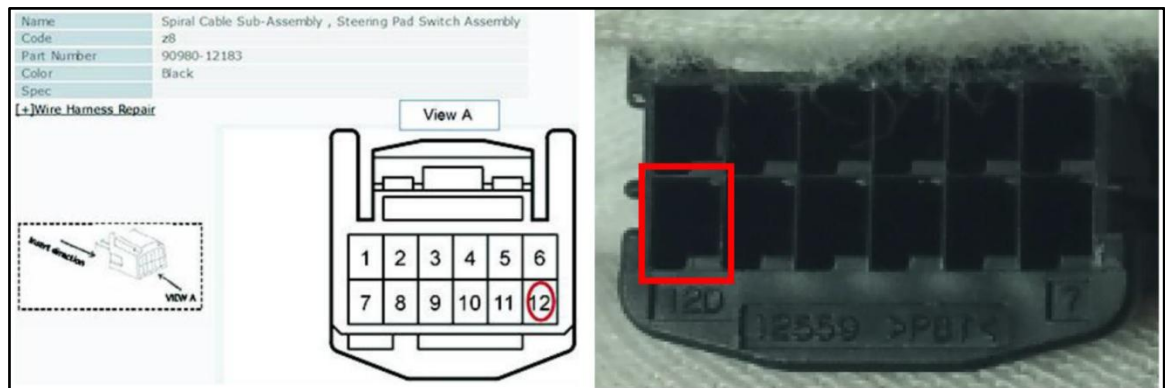

Cruise Control Stalk Illumination Intermittent Operation

Repair Procedure (Continued)

- C. For 2015 model year Sienna vehicles NOT equipped with a heated steering wheel (10-pin connector), insert PN 82998-08010 pin terminal into cavity 4 of connector Z2.

Figure 10.

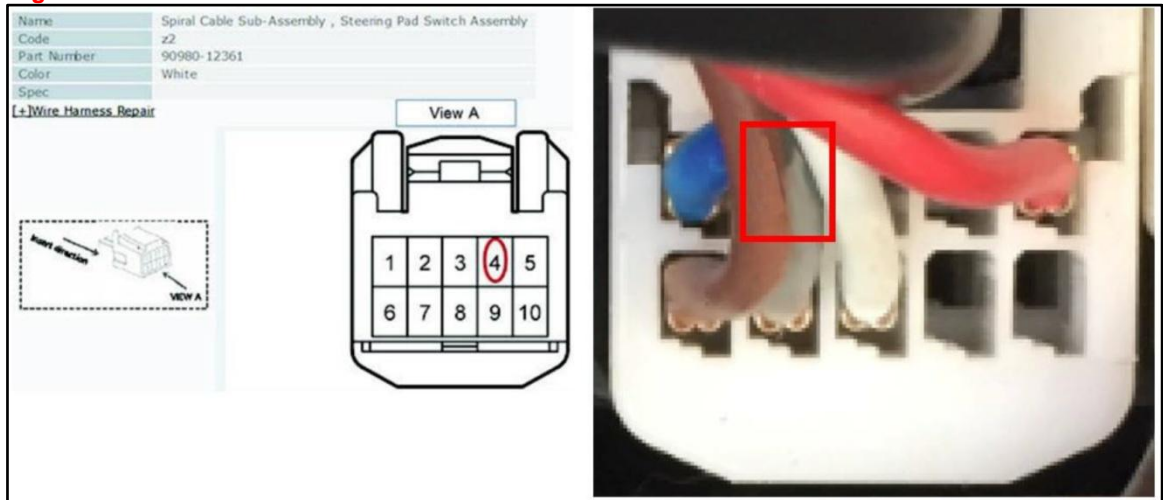

- 9. Press lock tab down. Make sure lock tab is fully seated by pressing in the areas indicated by the arrows.

Figure 11.

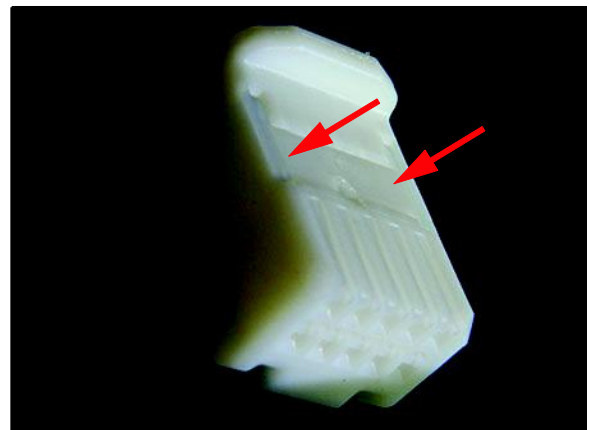

Cruise Control Stalk Illumination Intermittent Operation

Repair Procedure (Continued)

10. Connect Sienna connector Z8 (12-pin connector) or Z2 (10-pin connector) to spiral cable.

NOTE

Do NOT connect the Ring terminal end at this step. Be sure to route the harness under and away from SRS wiring.

Route the repair wire UNDER the existing brown (or black) wire sheath, following the path of the dotted line as shown. Do NOT attach ring terminal at this time.

NOTE

If the brown (or black) sheathed harness is routed to the right side of the steering wheel, route the repair harness on that side instead.

CAUTION

Place harness away from airbag connections.

Figure 12.



Cruise Control Stalk Illumination Intermittent Operation

Repair Procedure (Continued)

- On the underneath side of the steering column, disconnect the spiral cable sub-assembly connector D21 (12-pin connector) or D149 (14-pin connector) from the spiral cable as indicated.

Figure 13. D21 or D149 Locations

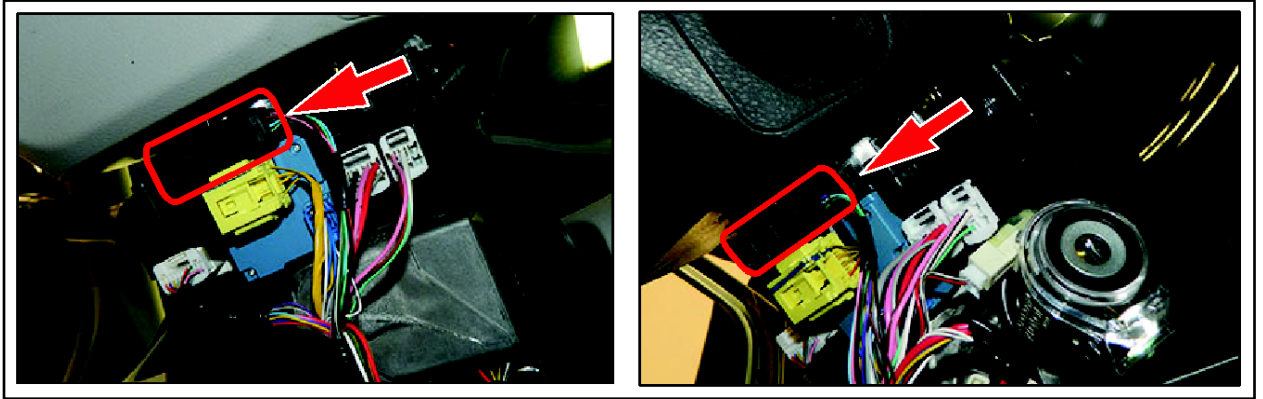

Figure 14. D21, 12-Pin Connector

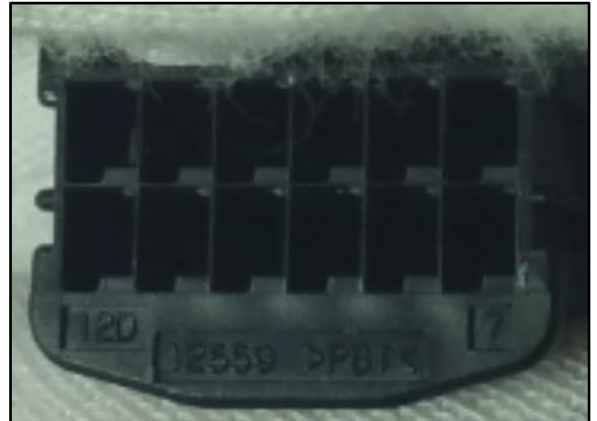

Figure 15. D149, 14-Pin Connector



Cruise Control Stalk Illumination Intermittent Operation

Repair Procedure (Continued)

12. Lift connector lock tab using same guidelines in step 7.

NOTE
Do NOT try to remove it. Only slightly lift.

Figure 16.



13. Insert terminal according to model year below.
 - A. For 2014 model year Sienna, insert repair wire PN 82998-08030 pin terminal into cavity 3 of connector spiral cable sub-assembly D21.

Figure 17.

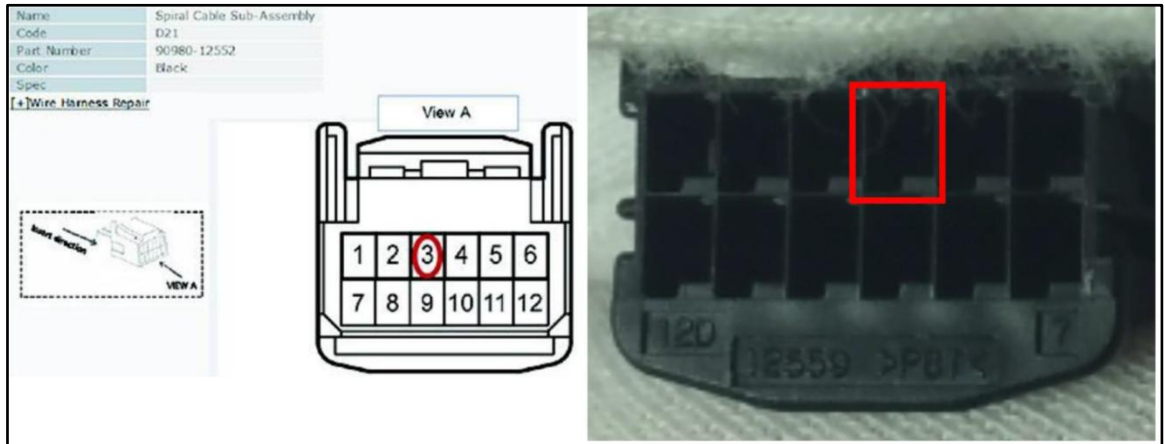

Cruise Control Stalk Illumination Intermittent Operation

Repair Procedure (Continued)

- B. For 2015 model year Sienna or later, 14-pin connector, insert repair wire PN 82998-08020 into cavity 7 of spiral cable sub-assembly D149.

Figure 18.

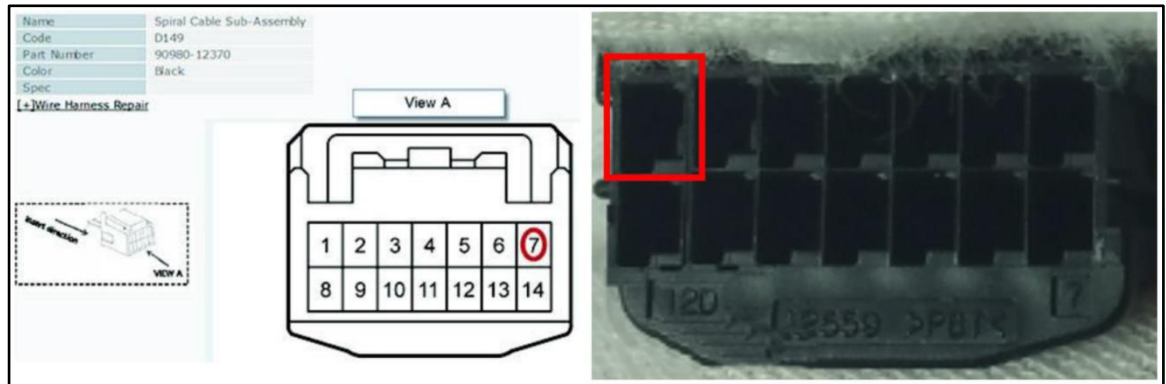

- C. For 2015 model year Sienna or later, 12-pin connector, insert repair wire PN 82998-08030 pin terminal into cavity 11 of spiral cable sub-assembly connector D21.

Figure 19.

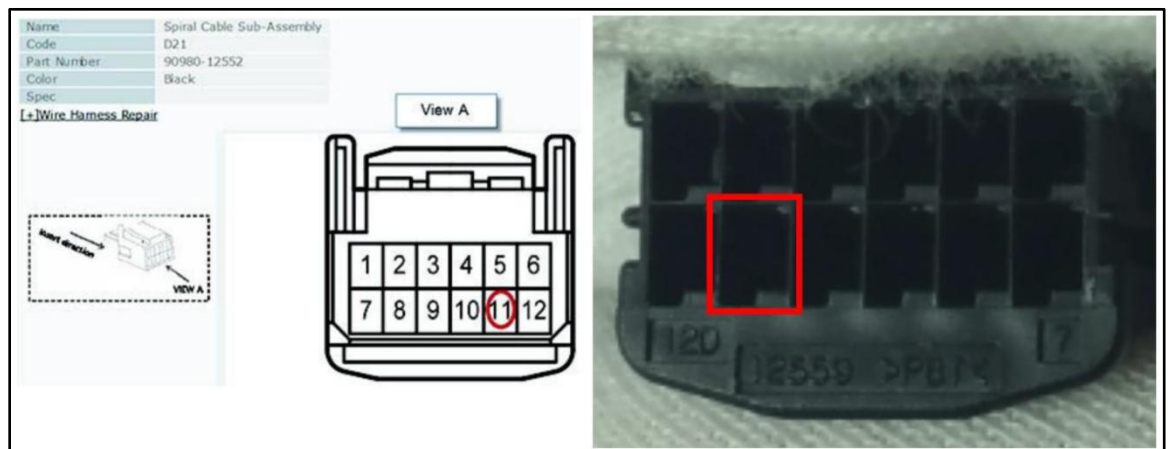

Cruise Control Stalk Illumination Intermittent Operation

Repair Procedure (Continued)

14. Press lock tab down on the connector.

Figure 20.

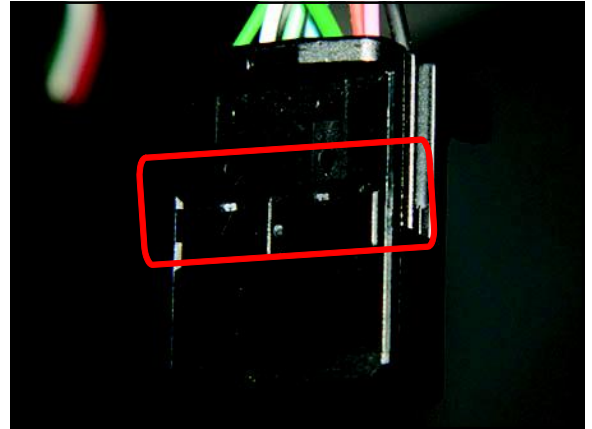

15. Connect harness connector D21 (12-pin connector) or D149 (14-pin connector) to spiral cable.

16. Check resistance between the ring terminals of both harnesses. The standard resistance is less than one ohm. If resistance is not as specified, check installation of both harnesses.

Figure 21.



Cruise Control Stalk Illumination Intermittent Operation

Repair Procedure (Continued)

17. Secure repair wire PN 82998-08010 or 82998-0E010 ring terminal to cruise control switch ground terminal.
 - A. Remove screw from cruise control switch ground terminal.
 - B. Place repair wire ring terminal over screw.
 - C. Reinstall screw in cruise control switch.
Torque: 2.4 N*m (24 kgf*cm, 21 ft*lbf)

Figure 22.



18. Route the repair wire from D21 or D149 on the underside of the steering column, following the arrows and routing along the wire harness. Place three cable ties near existing cable ties as shown.

NOTE

- All cable ties must be placed on plastic sheathing near existing locations.
- Check that the ignition switch is off.

CAUTION

Ensure no cable ties are applied on unprotected parts of harness without tape. They must be applied only on sheathing.

Figure 23.

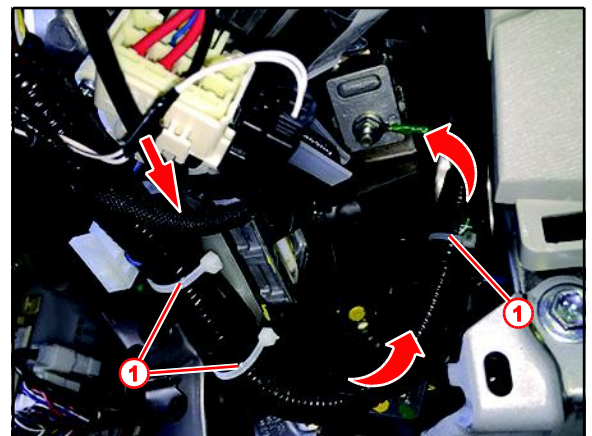

1	Cable Ties
----------	------------

Cruise Control Stalk Illumination Intermittent Operation

Repair Procedure (Continued)

19. Remove the steering column mount stud nut indicated in the picture and attach ring terminal to steering column mount stud.
Torque: 27.5 N*m (280 kgf*cm, 20 ft*lbf)

Figure 24.

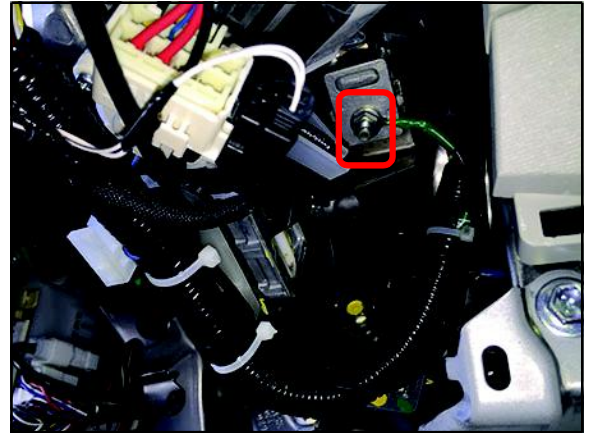

20. Install steering pad.

CAUTION

Some of these service operations affect the SRS airbag system. Read the precautionary notices concerning the SRS airbag system before installing the steering pad.

2014 / 2015 or later model year Sienna:

Vehicle Interior – Supplemental Restraint Systems – “Supplemental Restraint Systems: Airbag System: Precaution”

- A. Check that the ignition switch is off.
- B. Check that the cable is disconnected from the negative (–) battery terminal.

CAUTION

Wait at least 90 seconds after disconnecting the cable from the negative (–) battery terminal to disable the SRS system.

Cruise Control Stalk Illumination Intermittent Operation

Repair Procedure (Continued)

- C. Connect the horn terminal.

Figure 25.

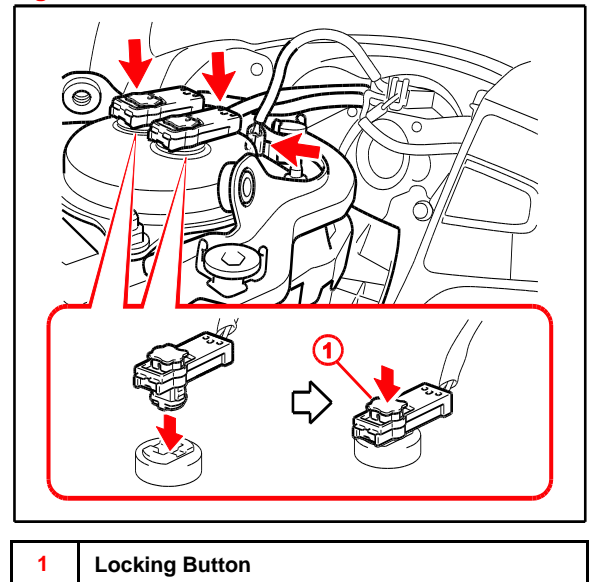

- D. Connect the 2 airbag connectors to the steering pad.

NOTICE

- When connecting any airbag connector, take care not to damage the airbag wire harness.
- Be sure to only connect the connectors to each corresponding color.
- Securely lock the locking button.

- E. For 2014 model year Sienna, confirm that the circumference groove of each screw fits in the screw case, and place the steering pad onto the steering wheel assembly.

Figure 26.

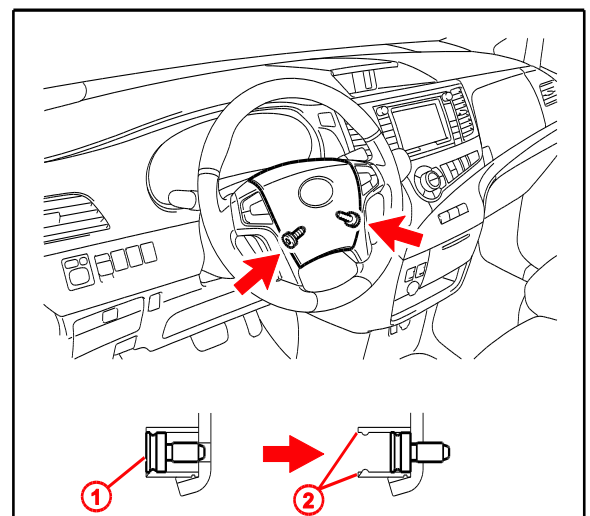

Cruise Control Stalk Illumination Intermittent Operation

Repair Procedure (Continued)

- F. Using a T30 torx® socket wrench, tighten the 2 screws.
Torque: 8.8 N*m (90 kgf*cm, 78 ft*lbf)
- G. For 2015 or later model year Sienna, engage the 3 pins with the 3 snap rings to install the steering pad.

NOTICE

Pull the steering pad to ensure that it is securely engaged.

- 21. Install the upper steering column cover.
 - A. Engage the 4 clips and 2 guides to install the upper steering column cover onto the instrument panel cluster finish panel.
 - B. Engage the claw to install the upper steering column cover.
- 22. Install the lower steering column cover.
 - A. Engage the 2 claws to install the lower steering column cover.
 - B. Install the 2 screws, except on Smart keys. These must be installed after the battery is connected.
 - C. Connect the cable to the negative battery terminal.
Torque: 5.4 N*m (55 kgf*cm, 48 ft*lbf)

NOTICE

When reconnecting the battery cable, some systems need to be initialized after the cable is reconnected.

[2014 / 2015](#) Sienna:

Introduction – Repair Instruction – “Introduction: Repair Instruction: Initialization”

- 23. Make sure that the horn sounds. If the horn does not sound, inspect the horn system. Refer to TIS, applicable model and model year Repair Manual:
 - [2014 / 2015](#) Sienna:
Horn – Horn System – “Horn: Horn System: Problem Symptoms Table”
- 24. Perform Techstream Health Check, assure no DTCs are present. Refer to TIS, applicable model and model year Repair Manual:
 - [2014 / 2015](#) Sienna:
Supplemental Restraint Systems – Airbag System – “Supplemental Restraint Systems: Airbag System: DTC Check”

Cruise Control Stalk Illumination Intermittent Operation

Repair Procedure (Continued)

25. Inspect SRS warning light is not illuminated.

If warning light illuminates, refer to TIS, applicable model and model year Repair Manual for diagnosis:

- [2014](#) / [2015](#) Sienna:

Supplemental Restraint Systems – Airbag System – “Supplemental Restraint Systems: Airbag System: Diagnosis System”