



© 2016 Mazda Motor of America, Inc.

<b>Subject:</b> <b>SPECIAL SERVICE TOOL LOANER ANNOUNCEMENT - AUGUST 2015</b>	<b>Bulletin No:</b> 00-005/16
	<b>Last Issued:</b> 08/26/2016

## BULLETIN NOTE

This bulletin supersedes the previously issued bulletin(s) listed below. The changes are noted in Red beside the change bars.

Previous TSBs:	Issued Dates:
00-001/15	08/06/15

## APPLICABLE MODEL(S)/VINS

2016 CX-3

2016 MX-5

## DESCRIPTION/PRICING

In support of the new Mazda MX-5 and CX-3, Mazda will make available for loan on a “as-needed” basis, a Special Service Tool (SST) to allow for the radar aiming of the blind spot monitoring (BSM) system. The (BSM) radar aiming is performed whenever the (BSM) control module, the (BSM) bracket or the rear bumper is replaced. The tool is available for loan on Mazda e-Store.

Part Number	Description	Pricing
49G0-67-0A0-L	Doppler Radar Simulator Tool (Loaner)	Shipping Cost (\$300 estimated)

## BILLING/WARRANTY INFORMATION

- For warranty related repairs that require usage of the tool, Mazda will reimburse freight charges if a copy of the closed Mazda e-Store order is attached to the warranty claim.
- For accident related repairs that require usage of the tool, dealers will be responsible for the shipping cost, to and from the dealer.

Tool shipping cost will be invoiced to your dealer parts account statement when ordered.

## SHIPPING INFORMATION

- Dealer is responsible for returning the tool within 3 days from the point of arrival. Please ensure all related repairs are completed prior to the tool’s arrival at the dealer.
- Dealer is responsible for packaging and returning the tool in the same condition as it was delivered.
- The tool will be shipped “Overnight” to your location, with a Return label enclosed.

**CONSUMER NOTICE:** The information and instructions in this bulletin are intended for use by skilled technicians. Mazda technicians utilize the proper tools/equipment and take training to correctly and safely maintain Mazda vehicles. These instructions should not be performed by “do-it-yourselfers.” Customers should not assume this bulletin applies to their vehicle or that their vehicle will develop the described concern. To determine if the information applies, customers should contact their nearest authorized Mazda dealership. Mazda North American Operations reserves the right to alter the specifications and contents of this bulletin without obligation or advance notice. All rights reserved. No part of this bulletin may be reproduced in any form or by any means, electronic or mechanical---including photocopying and recording and the use of any kind of information storage and retrieval system ---without permission in writing.

## SPECIAL SERVICE TOOL (SST) AND USAGE

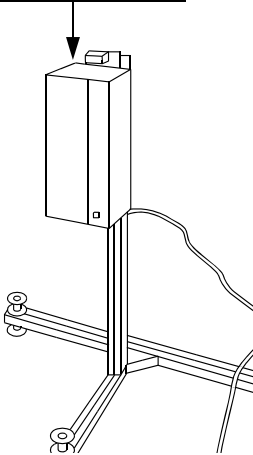
PART NUMBER / NAME:	OVERVIEW	USAGE
<p>49G0-67-0A0-L Doppler Radar Simulator Tool (Loaner)</p> <p><b>APPLICABLE MODELS:</b> 2016 CX-3 and MX-5</p> <p><b>USAGE:</b> For radar aiming of the Blind Spot Monitoring System (BSM).</p>	<p><b>49 G067 0A0</b></p> 	<p>Aiming procedure in the Workshop Manual - i-ACTIVESENSE section.</p> 