



© 2016 Mazda Motor of America, Inc.

Subject: WARNINGS AND CAUTIONS FOR CUSTOMERS CHANGING A FLAT TIRE	Bulletin No: 00-004/16
	Last Issued: 08/11/2016

APPLICABLE MODEL(S)/VINS

2000-2003 Protege	2000-2002 626	2000-2002 Millenia	2000-2006 MPV
2011-2017 Mazda2	2004-2017 Mazda3	2006-2014 Mazda5	2003-2017 Mazda6
2016-2017 CX-3	2013-2017 CX-5	2007-2012 CX-7	2007-2017 CX-9

DESCRIPTION

Raising a vehicle with a jack can be dangerous if not done properly. The vehicle can slip off the jack and seriously injure someone. In this service information, some important warnings and cautions have been taken from the Owner's Manual.

For Mazda customers who have questions about safely lifting their vehicle to change a flat tire or to install snow chains, please provide a copy of the attached handout for them. Also, be sure to always direct customers to follow the directions in the Owner's Manual.

CONSUMER NOTICE: The information and instructions in this bulletin are intended for use by skilled technicians. Mazda technicians utilize the proper tools/equipment and take training to correctly and safely maintain Mazda vehicles. These instructions should not be performed by "do-it-yourselfers." Customers should not assume this bulletin applies to their vehicle or that their vehicle will develop the described concern. To determine if the information applies, customers should contact their nearest authorized Mazda dealership. Mazda North American Operations reserves the right to alter the specifications and contents of this bulletin without obligation or advance notice. All rights reserved. No part of this bulletin may be reproduced in any form or by any means, electronic or mechanical---including photocopying and recording and the use of any kind of information storage and retrieval system ---without permission in writing.

CUSTOMER HANDOUT:

Before Lifting Your Vehicle With The Jack...

- Use only the jack provided with your Mazda vehicle.

WARNING: Using a jack that is not designed for your Mazda is dangerous. The vehicle could slip off the jack and seriously injure someone.

- Only use the jack for tire replacement and snow chain removal/installation. **DO NOT** use the jack for any other purposes.
- Make sure the jack screw threads are lubricated and the jack can be easily turned by hand.

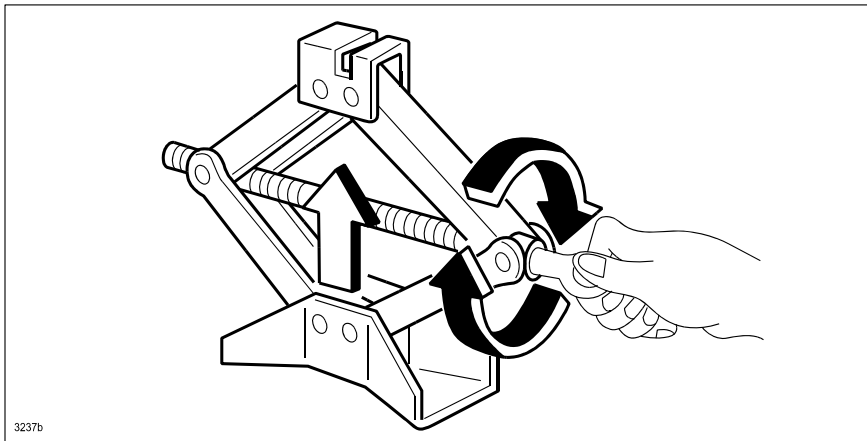

- If the jack cannot be easily turned by hand, remove all dirt, debris or corrosion from the threads (A), then lubricate the threads with WD-40 (or equivalent lubrication).

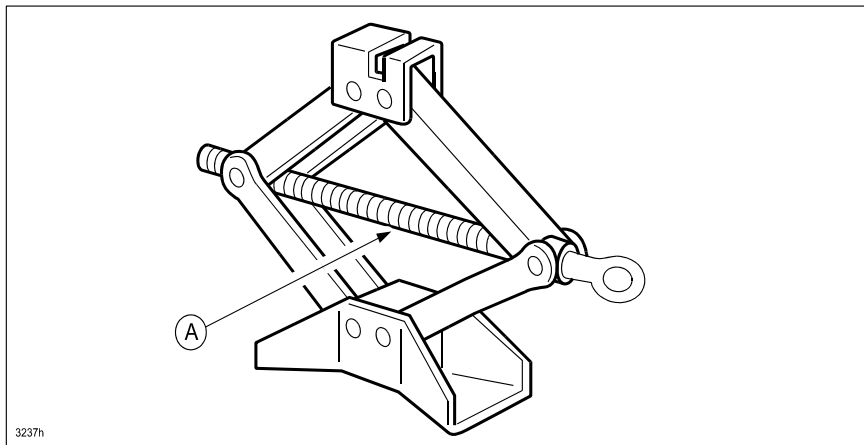

CAUTION: Poor lubrication could result in damaged threads and could cause the vehicle to fall off the jack.

- **NEVER** allow anyone inside the vehicle when it is supported by the jack.

WARNING: Allowing someone to remain in the vehicle supported by a jack is dangerous. If an occupant moves around in the vehicle, the vehicle could fall off the jack resulting in damage and/or serious injury.

1. Pull the vehicle off the road and onto a firm level surface.
2. Press the brake pedal to hold the vehicle in place.
3. Select the "P" position for automatic transmission (1st gear or R for manual transmission) and apply the parking brake.

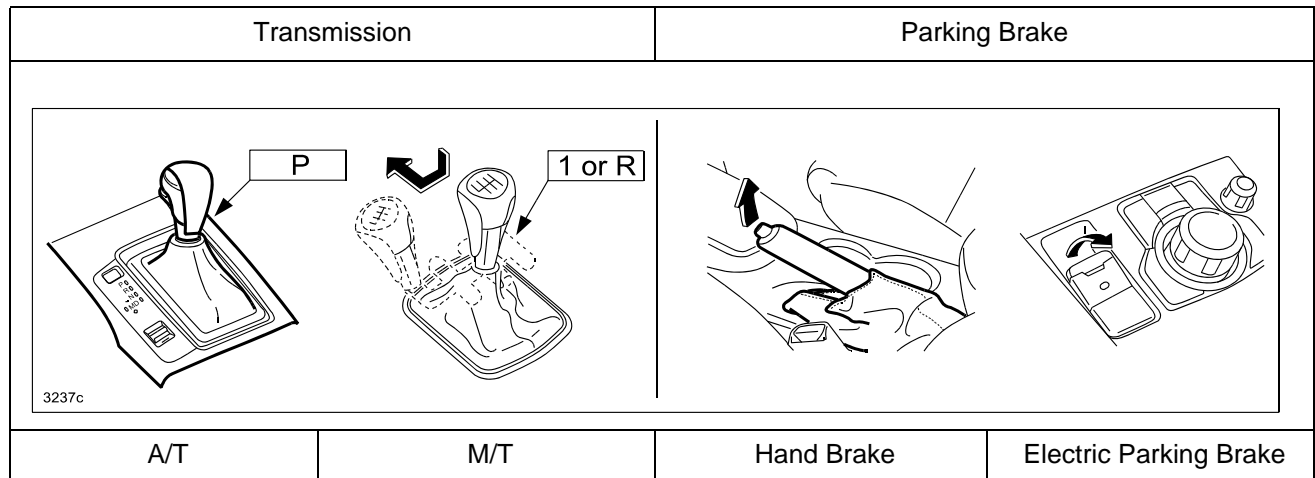

NOTE: Firmly setting the parking brake is important because the differential can move freely, even if the transmission position is set to P, 1st gear or R.

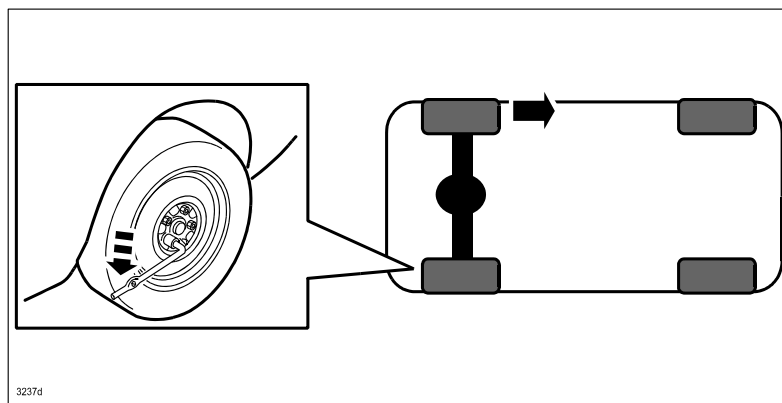

4. Turn off the engine.
5. Ensure that all occupants exit the vehicle.

6. Block the front and rear sides of the wheel (with bricks, large rocks, or suitable pieces of wood) that is diagonally opposite the flat tire (as shown below).

CAUTION: Loosening or tightening a wheel lug-nut with the lug-nut wrench may cause the vehicle to roll, so blocking a wheel is important.

Example: If the left-rear tire is flat, block the right-front wheel (A).

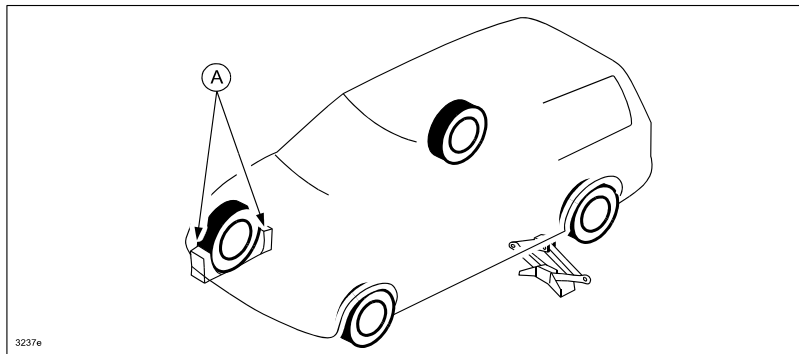

7. Use the lug-nut wrench (A) to break the lug-nuts loose.

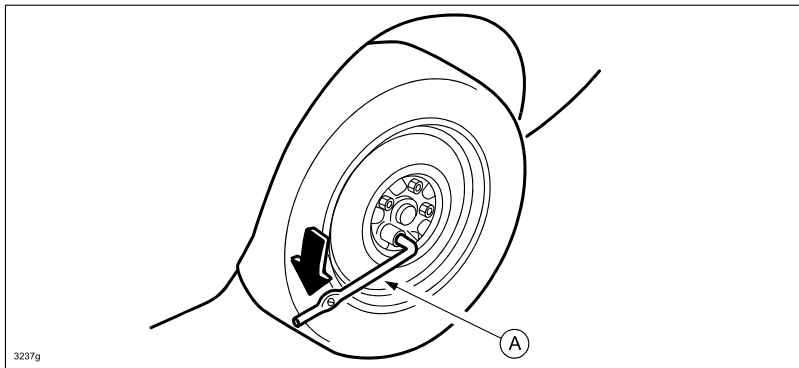

8. Turn the lug-nuts counter-clockwise one (1) turn each, but **DO NOT** remove any of them until the wheel has been raised off the ground with the jack.

Lifting Your Vehicle With The Jack...

1. Remove the jack and spare tire from the trunk or rear cargo area of your vehicle.
2. Position the jack under the vehicle in only the front or rear jacking positions that are recommended in the Owner's Manual.

WARNING: Attempting to lift the vehicle in positions other than those recommended in the Owner's Manual is dangerous. The vehicle could slip off the jack and could result in serious injury or death.

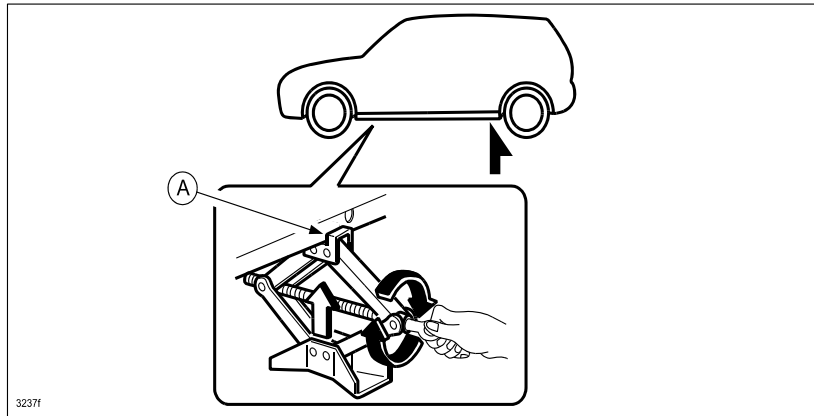

3. Raise the jack head gradually by rotating the jack screw with your hand (as shown above) until the "notch" in the jack head is properly aligned with the "lip" (A) on the bottom of the vehicle body.
4. Use the lug-nut wrench to continue turning the jack screw clockwise to raise the vehicle.

- **DO NOT** lift the vehicle up higher than necessary to remove the wheel assembly.

WARNING: Lifting the vehicle higher than necessary is dangerous as it could destabilize the vehicle resulting in an accident.

- **NEVER** place any objects on or under the jack.

WARNING: Placing objects on or under the jack is dangerous as it could deform the vehicle body or the vehicle could fall off the jack resulting in an accident.

- **NEVER** move under the vehicle while it is being lifted up.

WARNING: Moving under the vehicle while it is lifted up is dangerous as it could result in serious injury or death if the vehicle were to fall off the jack.

- **DO NOT** start the engine or shake the vehicle while the vehicle is lifted.

WARNING: Starting the engine or shaking the vehicle while it is lifted is dangerous as it could cause the vehicle to fall off the jack resulting in an accident.

- **DO NOT** open or close the doors while the vehicle is lifted.

WARNING: Opening or closing doors while the vehicle is lifted up is dangerous as it could cause the vehicle to fall off the jack resulting in an accident.

5. Once the wheel is raised slightly off the ground, remove the pre-loosened lug-nuts by hand.
6. Remove the flat tire and replace it with the spare tire.
7. Reinstall the lug-nuts and hand tighten them all.
8. Lower the vehicle slightly by turning the jack screw counter-clockwise until the tire touches the ground.
9. Once the tire touches the ground, use the lug-nut wrench to tighten all the lug-nuts (clockwise) in a criss-cross pattern.
10. Once the lug nuts are fully tightened, completely lower the vehicle to the ground, then remove the jack and the wheel blocks.
11. Place the flat tire and jack in the trunk or rear cargo area of your vehicle.