



SERVICE CAMPAIGN BULLETIN

Reference:

NTB16-078

Date:

August 23, 2016

VOLUNTARY SERVICE CAMPAIGN 2016 TITAN XD; DUAL WALL BEDLINER AND CARGO TIE DOWN KIT

CAMPAIGN ID #: PC423

APPLIED VEHICLES: 2016 Titan XD (A61)

Check Service COMM to confirm campaign eligibility.

INTRODUCTION

Nissan is conducting this voluntary service campaign on certain specific 2016 Titan XD vehicles to install a dual wall bedliner and a cargo tie down kit that should have been installed on the vehicle from the factory, but were not. This service will be performed at no charge to the customer for parts or labor.

IDENTIFICATION NUMBER

Nissan has assigned identification number PC423 to this campaign. This number must appear on all communications and documentation of any nature dealing with this campaign.

DEALER RESPONSIBILITY

Dealers are to repair vehicles falling within range of this campaign that enter the service department. This includes vehicles purchased from private parties, vehicles presented by transient (tourists) owners, and vehicles in a dealer's inventory.

Nissan Bulletins are intended for use by qualified technicians, not 'do-it-yourselfers'. Qualified technicians are properly trained individuals who have the equipment, tools, safety instruction, and know-how to do a job properly and safely. NOTE: If you believe that a described condition may apply to a particular vehicle, DO NOT assume that it does. See your Nissan dealer to determine if this applies to your vehicle.

SERVICE PROCEDURE

1. Apply the parking brake.

2. Install the dual wall bedliner using the accessory installation instructions starting on page 3.
 - Order required parts using the Parts Information below.

3. Install the cargo tie down kit using the accessory installation instructions starting on page 7.
 - Order required parts using the Parts Information below.

PARTS INFORMATION

DESCRIPTION	PART NUMBER	QUANTITY
Dual Wall Bedliner – Titan Box RH (Storage Box)	999T1-W3771 (1)	1
Dual Wall Bedliner – Titan Box LH (Storage Box)	999T1-W3772 (1)	1
Cleat – Cargo Tie Down Kit	999T7-W3800 (2)	1

(1) Order the Titan Box from OE Liner™/Penda at 800-635-4637.

(2) Order the Cargo Tie Down Kit from your local PDC.

Dual Wall Bedliner



GENUINE PARTS

INSTALLATION INSTRUCTIONS

DESCRIPTION:	Dual Wall Bedliner
APPLICATION:	Titan
PART NUMBER:	999T1 W37x0
KIT CONTENTS:	

Order parts using the parts information on page 2.

Item	Qty.	Part Description	Service Part Number
A	1	Bin Assembly	n/a
B	4	M8 Rivnut	n/a
C	4	M8 Washer	n/a
D	4	M8 Spacer	n/a
E	4	M8 X 33 Shldr Bolt	n/a
F	4	M6 Rivnut	n/a
G	4	M6 Washer	n/a
H	4	M6 X 25 Shldr Bolt	n/a
I	1	Installation Instruction Replacement Template	n/a

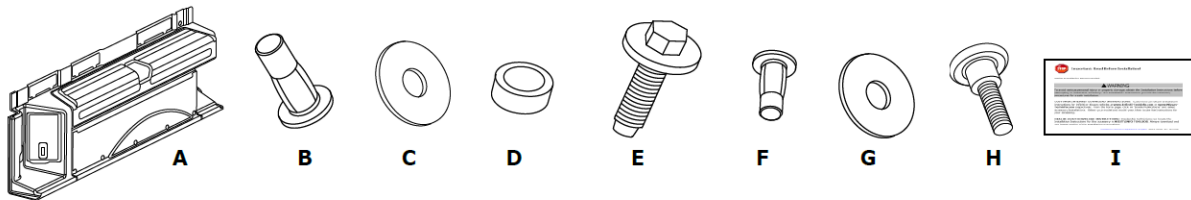

TOOLS REQUIRED:

- Driver Nut with Variable Torque Setting
- Rivnut Installation Tool
- 10MM Socket
- T30 Torx Driver
- Extension 6"

PRE-INSTALLATION WARNINGS, CAUTIONS, CRITICAL STEPS, and NOTES:

- Dealer Installation Recommended. Instructions may refer to Service Manual.

⚠ WARNING

- Static electricity can cause an explosion of flammable liquid vapor or gas in any vehicle or trailer. Do not use bedliner or tailgate cover as a surface for filling a container with flammable liquid.

⚠ CAUTION

- Installation of the bedliner requires two people. Do not attempt to install the bedliner by yourself.
- For proper installation, the sheet metal truck box and bedliner must be at room temperature (65-80 F) at the time of installation.

Dual Wall Bedliner – continued

INSTALLATION PROCEDURE:

- 1) Apply parking brake.

⚠ CAUTION

- Read entire installation procedure prior to installing new bedliner in order to become familiar with process.

Driver side shown. Repeat steps 3 through 7 for passenger side installation.

- 2) Before installing dual wall bedliner, thoroughly clean bed. (Figure 1).

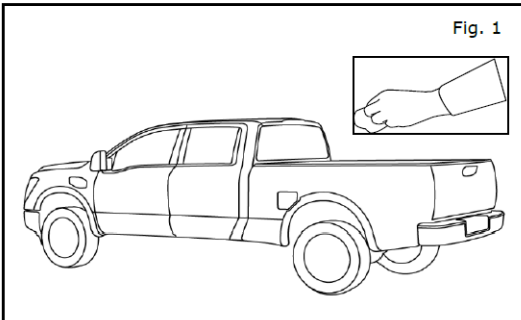

- 3) Install M8 and M6 rivnuts as follows:
 - a) Install M8 rivnuts in locations shown in Figure 2. Using Rivnut installation tool install M8 rivnut using washer under head Figure 3.
 - b) Install M6 rivnuts in locations shown in Figure 2 using installation tool. Washers are not required for M6 rivnut installation.

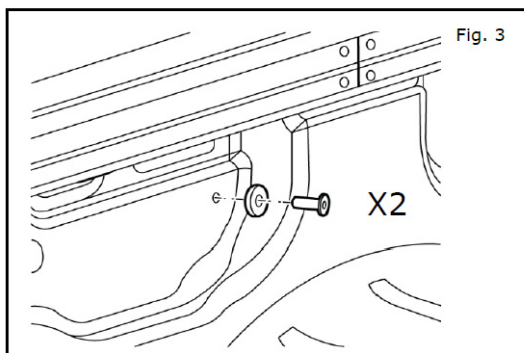
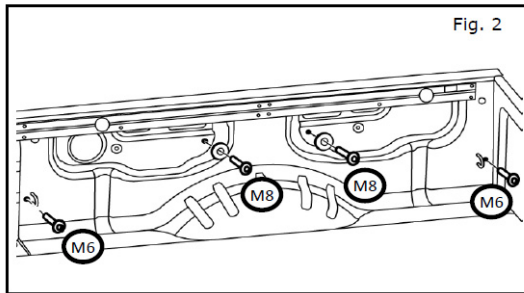

Dual Wall Bedliner – continued

INSTALLATION PROCEDURE:

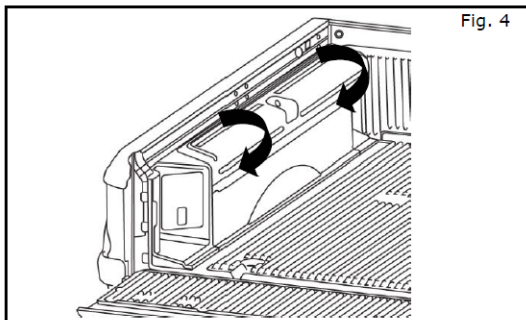

- 4) Position bin assembly near sidewall of truck box (Figure 4). Angle top of bin assembly so upper tabs are positioned behind Utili-trac trail.

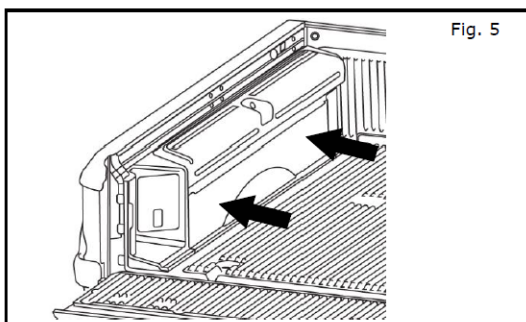

- 5) Push bin assembly tight to side of wall of truck box and align fastener holes with M8 and M6 rivnuts. Ensure fixed tie down loops slide through assembly cutouts. (Figures 5 and 6).

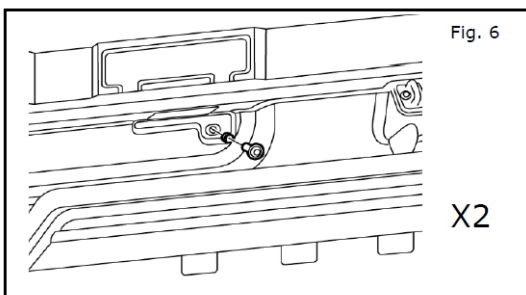

- 6) Open bin assembly lid and install M8 spacer and M8X33 bolt. Install in (2) locations (Figure 7). Tighten screws to 10Nm.

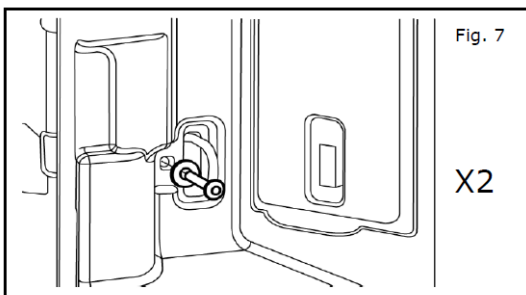

- 7) At front and rear tie down holes, install M6 x 25 shldr bolt and washer (2) locations. Tighten bolts to 5Nm.

Dual Wall Bedliner – continued

INSTALLATION PROCEDURE:

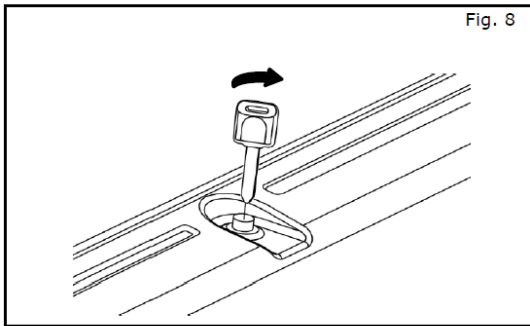

- 8) Code accessory key to bin lock.
 - a) Insert accessory key into bin lock.
 - b) Turn accessory key clockwise to code key.
 - c) Repeat for opposite side.

NOTE: Key may need to be wiggled back and forth during coding process.

Cargo Tie Down Kit



GENUINE PARTS

INSTALLATION INSTRUCTIONS

DESCRIPTION:	Cleat - Cargo Tie Down Kit
APPLICATION:	Titan
PART NUMBER:	999T7 W3800
KIT CONTENTS:	

Order parts using the Parts Information on page 2. These part numbers are for installation instruction reference only.

Item	Qty.	Part Description	Service Part Number
A	4	Cleat - Cargo Tie Down (Cleat Assembly)	999T7 W3810
B	2	Cleat Stop (End Stop Assembly)	999T7 W3820
C	1	Installation Instructions Replacement Template	999V2 AW000

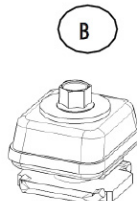
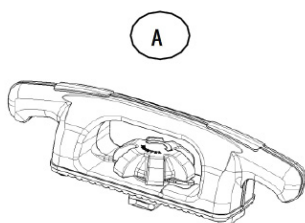

STOP Important: Read Before Installation

Dealer Installation Recommended.

WARNING
To avoid serious personal injury or property damage, read the installation instructions before attempting to install this accessory. The installation instructions provide the correct procedure for safe installation.

CUSTOMER INTERNET DOWNLOAD INSTRUCTIONS: Customers can obtain installation instructions for Infiniti or Nissan vehicles at www.InfinitiTechnic.com or www.NissanUSA.com respectively. From the home page, select Accessory or Parts/Tools, select your MODEL, Model Year, and Accessory Type or select the year, Model, and/or Model Year, and/or Accessory Type or Part Number, then locate the instructions for your accessory.

DEALER ASSIST DOWNLOAD INSTRUCTIONS: Dealership technicians can locate the installation instructions for this accessory by scrolling to and select ACC. 99999. INSTRUCTIONS can always download and use latest version of the installation instructions.

Installation Instructions Replacement Template 999V2 AW000 Rev. 04/05/14

TOOLS REQUIRED:

- Safety Glasses
- 10mm Socket
- Socket Wrench
- Torque Wrench

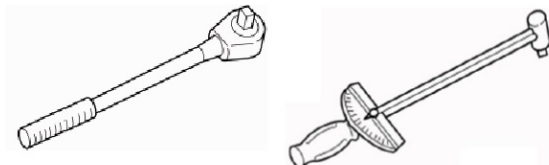

PRE-INSTALLATION WARNINGS, CAUTIONS, CRITICAL STEPS, and NOTES:

CAUTION

- Bolts must be tightened according to the specified torque values.

Cargo Tie Down Kit – continued

INSTALLATION PROCEDURE:

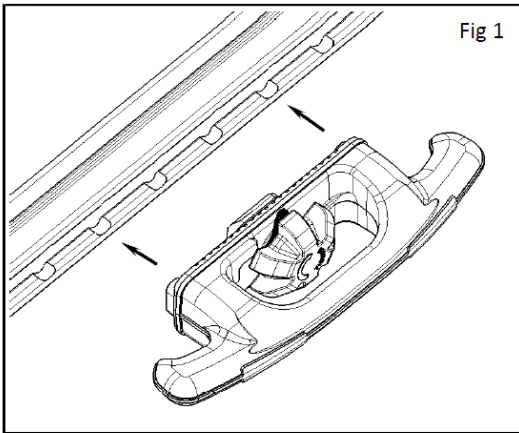

- 1) Line up lugs on underside of cleat with notches in the channel. See Fig. 1

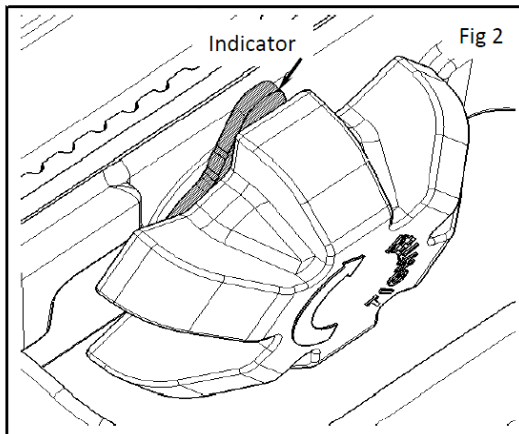

- 2) Make sure indicator is in the unlocked position. See Fig. 2

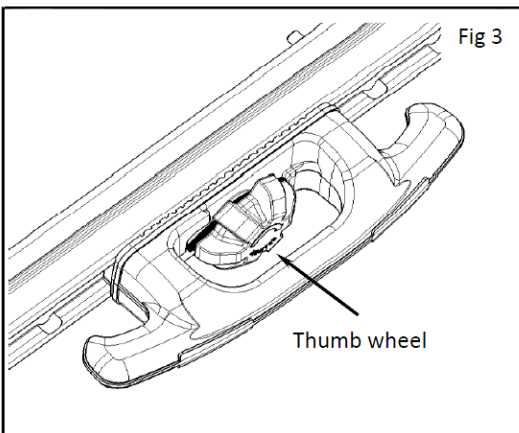

- 3) Position cleat into channel until flush with channel opening. Rotate thumb wheel clock-wise until tight (22 in lbs max.) See Fig. 3

2 of 4

Cargo Tie Down Kit – continued

INSTALLATION PROCEDURE:

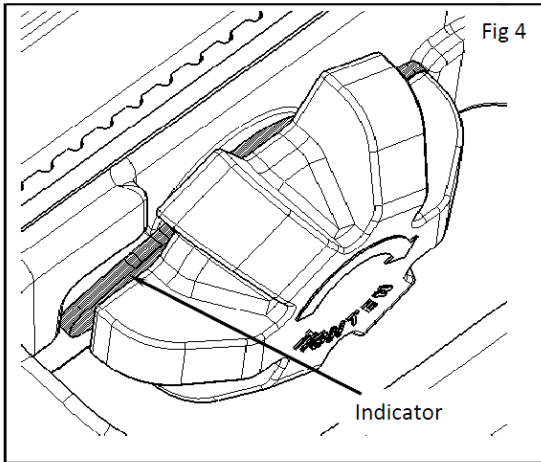

- 4) Indicator should be in locked position as shown. See fig. 4

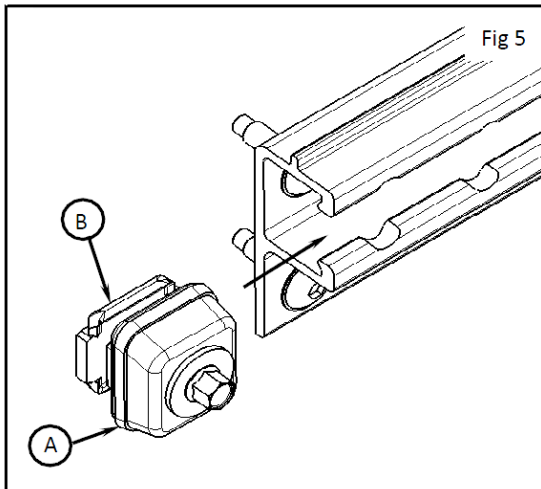

- 5) Slide endstop into channel opening. Channel to be positioned between body (A) and plate (B). See Fig. 5

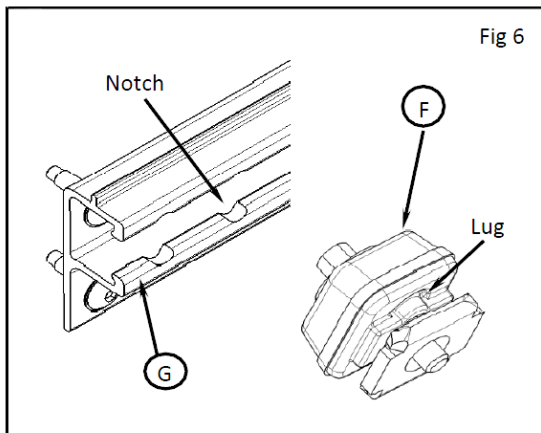

- 6) Align lugs on body (F) to notches on channel (G) in desired location. See Fig. 6

Cargo Tie Down Kit – continued

INSTALLATION PROCEDURE:

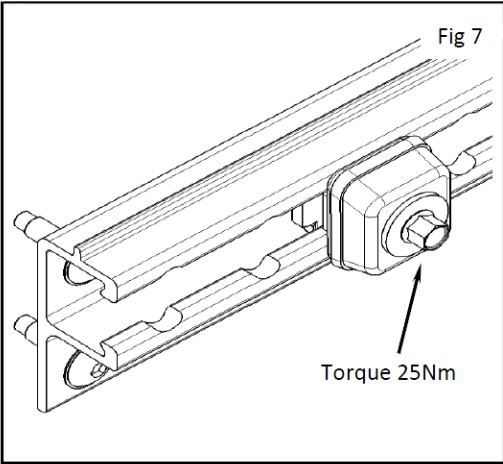

- 7) Torque bolt to 25Nm using 10mm socket wrench. See Fig. 6

CLAIMS INFORMATION

Submit a Campaign (CM) line claim using the following claims coding:

CAMPAIGN (CM) I.D. #	DESCRIPTION	OP CODE	FRT
PC423	Install Dual Wall Bed Liner (storage box) and Cargo Tie Down Kit	PC4230	0.8 hrs.

