



# Technical Service Bulletin

SUBJECT:		No: <b>TSB-16-54-004</b>	
<b>TAIL LIGHT REMOVAL &amp; INSTALLATION PROCEDURE – SERVICE MANUAL REVISION</b>		DATE: <b>October, 2016</b>	
		MODEL: <b>2016 Outlander</b>	
CIRCULATE TO:	<input type="checkbox"/> GENERAL MANAGER	<input checked="" type="checkbox"/> PARTS MANAGER	<input checked="" type="checkbox"/> TECHNICIAN
<input checked="" type="checkbox"/> SERVICE ADVISOR	<input checked="" type="checkbox"/> SERVICE MANAGER	<input type="checkbox"/> WARRANTY PROCESSOR	<input type="checkbox"/> SALES MANAGER

## PURPOSE

This TSB updates the Chassis Electrical section of the affected Service Manuals to correct a reference in Tail Light removal and installation.

## AFFECTED VEHICLES

- 2016 Outlander

## AFFECTED SERVICE MANUALS

2016 Outlander Service Manual, Group 54 – Chassis Electrical –> Rear Combination Light –> Tail Light.



Please make the indicated changes to the 2016 Outlander Service Manual, Group 54A – Chassis Electrical → Rear Combination Light → Tail Light → Removal and Installation.

Pre-removal and Post-installation Operation <Correct>  
 • Liftgate Trim Removal and Installation  
 (Refer to GROUP 52A-Liftgate Trim).

### TAIL LIGHT REMOVAL AND INSTALLATION

M1541402600282

~~Pre-removal and Post-installation Operation <Incorrect>~~  
~~• Liftgate garnish Removal and Installation (Refer to GROUP 51-Liftgate garnish).~~

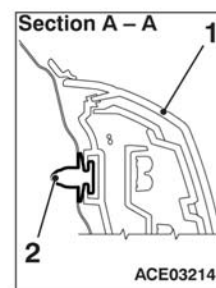
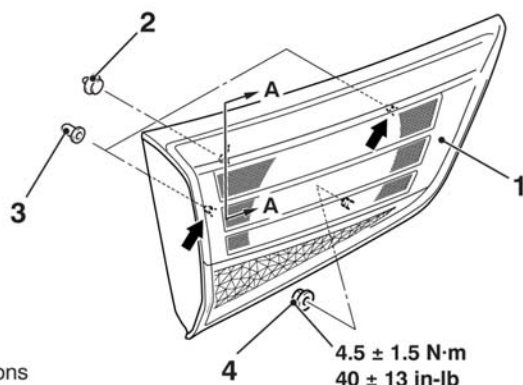

ACE03212AB

NOTE  
 ← : Stud pin positions

#### Removal Steps

- <<A>> >>A<<
1. Tail light assembly
  2. Clip

#### Removal Steps (Continued)

3. Grommet
4. Nut

### REMOVAL SERVICE POINT

#### <<A>> TAIL LIGHT ASSEMBLY REMOVAL

Disengage the clip by inserting the special tool Ornament remover (MB990784) as shown. Then remove the tail light assembly.

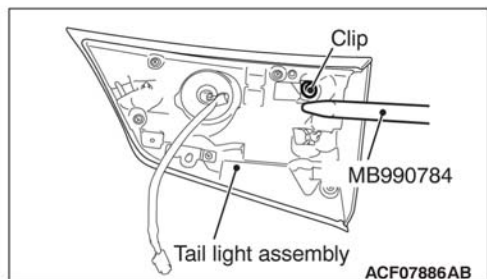

### INSTALLATION SERVICE POINT

#### >>A<< TAIL LIGHT ASSEMBLY INSTALLATION

**CAUTION**

When installing the tail light assembly, roll up the weather-strip and secure it by a tape as shown to avoid trapping it.

