



Bulletin No.: 14520A  
Date: March 2016

# Service Bulletin

## SPECIAL COVERAGE

**SUBJECT:** Special Coverage Adjustment – Fractured Leaf Springs

**MODELS:** 2008-2009 Chevrolet Silverado LD  
2008-2009 GMC Sierra LD  
Currently Registered or Previously Registered in Maine, New Hampshire, New York, Vermont and Canada

and

2007, 2010-2013 Chevrolet Silverado LD  
2007, 2010-2013 GMC Sierra LD  
Currently Registered or Previously Registered in Maine, New Hampshire, New York, and Vermont; New Brunswick, Newfoundland, Nova Scotia, Prince Edward Island, Ontario, and Quebec

This bulletin is being revised to add model years, expand coverage to the U.S. States identified above, revise the parts information and the service procedure. Please discard all copies of bulletin 14520.

For pre-2010 vehicles, this special coverage adjustment is intended as a reimbursement program for customers who may have incurred a repair expense outside the terms of the new vehicle limited warranty. Customers who required rear-leaf spring replacement due to a leaf-spring fracture during the 5 year / 100,000mile (160,000 km) warranty extension are eligible for reimbursement under this program.

Dealers are to refer to the General Motors Service Policies and Procedures Manual, Section 1.1.1.B - Vehicles Outside of a Special Coverage Adjustment, for guidelines on handling vehicles that are not involved in this special coverage but may be displaying the same condition.

### CONDITION

Some 2008-2009 model year Chevrolet Silverado and GMC Sierra light-duty vehicles registered in Canada or 2007, and 2010-2013 model year Chevrolet Silverado and GMC Sierra light duty vehicles registered in or previously registered in Maine, New Hampshire, New York, and Vermont or in the Canadian provinces New Brunswick, Newfoundland, Nova Scotia, Prince Edward Island, Ontario, and Quebec may develop a fractured middle-leaf spring in the three-leaf rear-suspension spring assembly, forward or rearward of the joint to the rear axle. This condition may result in noise, ride-height difference, contact with a rear tire, and/or damage to other components under the vehicle. Vehicles with this condition will have reduced load-carrying capacity.

## SPECIAL COVERAGE ADJUSTMENT

This special coverage adjustment covers the condition described above for a period of 5 years or 100,000 miles (160,000 kilometers), whichever occurs first, from the date the vehicle was originally placed in service, regardless of ownership.

**For 2008-2009 vehicles** covered by Vehicle Service Contracts, all eligible claims with repair orders on or after April 28, 2015, are covered by this special coverage and must be submitted using the labour operation codes provided with this bulletin. Claims with repair orders prior to April 28, 2015, must be submitted to the Service Contract provider.

**For 2007, 2010-2013 vehicles** covered by Vehicle Service Contracts, all eligible claims with repair orders on or after March 8, 2016, are covered by this special coverage and must be submitted using the labour operation codes provided with this bulletin. Claims with repair orders prior to March 8, 2016, must be submitted to the Service Contract provider.

## VEHICLES INVOLVED

All involved vehicles are identified by Vehicle Identification Number on the Applicable Warranties section in GM Global Warranty Management system. Dealership service personnel should always check this site to confirm vehicle involvement prior to beginning any required inspections and/or repairs. It is important to routinely use this tool to verify eligibility because not all similar vehicles may be involved regardless of description or option content.

## PART INFORMATION

Parts required to complete this special coverage are to be obtained from General Motors Customer Care and Aftersales (GMCC&A). Use the vehicle identification number (VIN) and the GM Electronic Parts Catalog (EPC) to determine which part to order. Refer to the parts table below.

Part Number	Description	Quantity/Vehicle
23401108	SPRING, RR LEAF	2
23418311	SPRING, RR LEAF	2
23469809	SHIM KIT*	2 (If Req'd)

\*The following models require the shim kit for installation. If the model is NOT specified below, a shim kit is NOT required for this repair.

- C, 105, 43 (2wd Crew Cab) WITHOUT any of the following RPOs: HP2, NHT or XFE
- C, 107, 53 (2wd Extended Cab) WITHOUT any of the following RPOs: HP2 or NHT
- C, 109, 53 (2wd Extended Cab)
- C, 105, 43 (2wd Crew Cab) with RPO HP2

## SERVICE PROCEDURE

1. Verify that the leaf spring assembly requires replacement. Raise and support vehicle. Refer to *Lifting and Jacking* in SI. Perform a visual inspection of leaf springs for a fracture. Inspect for a fractured middle leaf spring in the three leaf rear suspension spring assembly, forward or rearward of the joint to the rear axle.
  - If the leaf spring assemblies (driver and passenger side) do NOT require replacement, no further action is required. Inform the customer that any additional diagnosis and repairs are not covered under this special coverage.

- If the leaf spring assembly (driver or passenger side) requires replacement, **inform the customer that all repairs made after 5 years or 100,000 miles (160,000 kilometers), whichever occurs first, from the date the vehicle was originally placed in service are at customer pay.**
2. Remove the leaf springs from both sides of the vehicle. Refer to *Leaf Spring Replacement* in SI.
  3. On certain models, a shim kit must be utilized to ensure proper spring orientation. Using the VIN, refer to the EPC to determine if a shim kit is required.
    - If the vehicle requires a shim, continue to STEP 4.
    - If the vehicle does not require a shim, continue to STEP 7.
  4. Remove the center bolt and nut from the new leaf springs.

**Caution:** Incorrect orientation of the shim will cause an improper driveline angle of the rear axle.

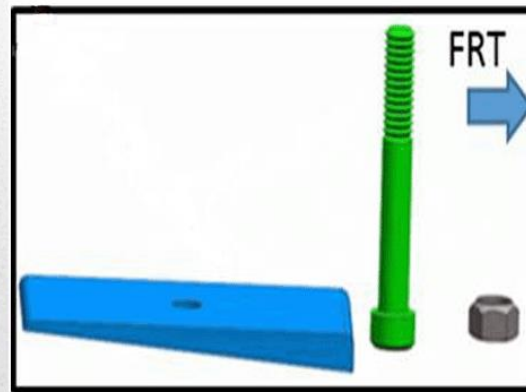

4372465

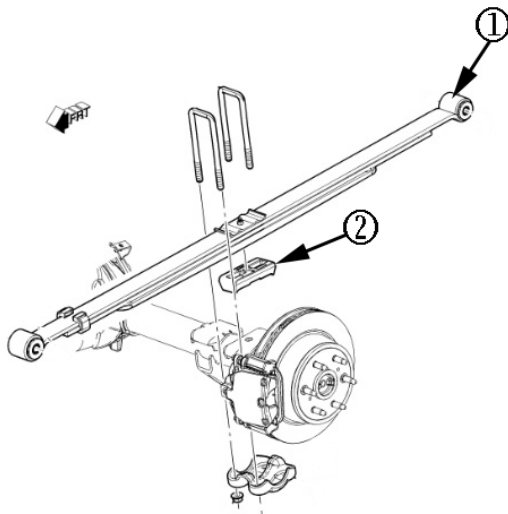

4372472

5. Install shim in the direction OPPOSITE of its marking; specifically, install the thinner end of the shim with the word "FRONT" stamped on it toward the rear of the vehicle between the leaf spring (1) and the spacer (2) on both sides of the vehicle.
6. Install the new center bolt and nut that was included in the shim kit into the new leaf springs and tighten to 100 Nm (74 lb ft).
7. Install the new leaf springs on both sides of the vehicle. Refer to *Leaf Spring Replacement* in SI.

### CUSTOMER REIMBURSEMENT

Customer requests for reimbursement of previously paid repairs to correct the condition described in this bulletin are to be submitted to the dealer prior to or by March 31, 2017. Repairs must have occurred within the 5 years of the date the vehicle was originally placed in service, or 100,000 miles (160,000 kilometers), whichever occurs first.

When a customer requests reimbursement, they must provide the following:

- Proof of ownership at time of repair.
- Original paid receipt confirming the amount of unreimbursed repair expense(s) (including Service Contract deductibles), a description of the repair, and the person or entity performing the repair.

All reasonable and customary costs to correct the condition described in this bulletin should be considered for reimbursement. Any questions or concerns should be reviewed with your GM representative prior to processing the request.

### COURTESY TRANSPORTATION

The General Motors Courtesy Transportation program is intended to minimize customer inconvenience when a vehicle requires a repair that is covered by the New Vehicle Limited Warranties. The availability of courtesy transportation to customers whose vehicles are within the warranty coverage period and involved in a product program is very important in maintaining customer satisfaction. Dealers are to ensure that these customers understand that shuttle service or some other form of courtesy transportation is available and will be provided at no charge. Dealers should refer to the General Motors Service Policies and Procedures Manual for Courtesy Transportation guidelines.

**WARRANTY TRANSACTION INFORMATION**

Submit a transaction using the appropriate table below. All transactions should be submitted as a ZREG transaction type, unless noted otherwise.

**Note:** For reimbursements on vehicles covered under warranty, refer to the Policies and Procedures Manual.

<b>For Use With Vehicles <u>Still Covered</u> Under Applicable New Vehicle Limited Warranties</b>		
<b>Labour Code</b>	<b>Description</b>	<b>Labour Time</b>
8049929	Suspension – Customer Concern Not Duplicated	0.1-0.3
8042381	Rear Spring Replacement - Both Sides Add: With Tank Shield	2.9 0.1

<b>For Use With Vehicles <u>No Longer Covered</u> Under Applicable New Vehicle Limited Warranties but within 5 years / 100,000miles (160,000km)</b>			
<b>Labour Code</b>	<b>Description</b>	<b>Labour Time</b>	<b>Net Item</b>
9900154	Suspension – Customer Concern Not Duplicated	0.1-0.3	N/A
9900155	Rear Spring Replacement - Both Sides Add: With Tank Shield	2.9 0.1	N/A
9900156	Customer Reimbursement Approved	0.2	*
9900316	Customer Reimbursement Denied – For US Dealers Only	0.1	N/A

\*The amount identified in “Net Item” should represent the dollar amount reimbursed to the customer.

**CUSTOMER NOTIFICATION**

General Motors will notify customers of this special coverage on their vehicles (see copy of typical customer letter included with this bulletin - actual divisional letter may vary slightly).



March 2016

This notice applies to your vehicle, **VIN:** \_\_\_\_\_

Dear General Motors Customer:

As the owner of a 2008-2009 model year Chevrolet Silverado or GMC Sierra light-duty vehicle registered or previously registered in Maine, New Hampshire, New York, Vermont and Canada, or a 2007, or 2010-2013 model year Chevrolet Silverado and GMC Sierra light duty vehicle registered in, or previously registered in Maine, New Hampshire, New York, and Vermont or in the Canadian provinces New Brunswick, Newfoundland, Nova Scotia, Prince Edward Island, Ontario, and Quebec your satisfaction with our product is very important to us.

This letter is intended to make you aware that some 2007-2013 Chevrolet Silverado or GMC Sierra light duty vehicles (as defined above), may have a condition where a fractured middle-leaf spring develops in the three-leaf rear-suspension spring assembly, forward or rearward of the joint to the rear axle. This condition may result in noise, ride-height difference, contact with a rear tire, and/or damage to other components under the vehicle. Vehicles with this condition will have reduced load-carrying capacity.

**Do not take your vehicle to your GM dealer as a result of this letter unless you believe that your vehicle has the condition as described above.**

**What We Have Done:** General Motors is providing owners with additional protection for the condition described above. If this condition occurs on your 2007-2013 model year Chevrolet Silverado or GMC Sierra within 5 years of the date your vehicle was originally placed in service or 100,000 miles (160,000 km), whichever occurs first, the condition will be repaired for you at **no charge**. Diagnosis or repair for conditions other than the condition described above is not covered under this special coverage program.

***Your vehicle may be outside of the extended-warranty period. But even if your extended warranty has expired, you may be eligible for reimbursement if you paid for repairs for this condition during the extended-warranty period. Please complete the enclosed reimbursement form and present it to your dealer with all required documents.***

**What You Should Do:** If you believe that your vehicle has the condition described above, repairs and adjustments qualifying under this special coverage must be performed by a General Motors dealer. You may want to contact your GM dealer to find out how long they will need to have your vehicle so that you may schedule the appointment at a time that is convenient for you. This will also allow your dealer to order parts if they are not already in stock. Keep this letter with your other important glove box literature for future reference.

**Reimbursement:** If you have paid for repairs for the condition described in this letter, please complete the enclosed reimbursement form and present it to your dealer with all required documents. Working with your dealer will expedite your request, however, if this is not convenient, you may mail the completed reimbursement form and all required documents to Reimbursement Department, PO Box 33170, Detroit, MI 48232-5170. The completed form and required documents must be presented to your dealer or received by the Reimbursement Department by March 31, 2017, unless state law specifies a longer reimbursement period.

If you have any questions or need any assistance, just contact your dealer or the appropriate Customer Assistance Center at the number listed below.

Division	Number	Text Telephones (TTY)
Chevrolet	1-800-630-2438	1-800-833-2438
GMC	1-866-996-9463	1-800-462-8583
Puerto Rico – English	1-800-496-9992	
Puerto Rico – Español	1-800-496-9993	
Virgin Islands	1-800-496-9994	

We are sorry for any inconvenience you may experience; however, we have taken this action in the interest of your continued satisfaction with our products.

Terry M. Inch  
Executive Director  
Global Connected Customer Experience

Enclosure  
14520A

GLOBAL SAFETY FIELD INVESTIGATIONS  
DCS3954  
URGENT - DISTRIBUTE IMMEDIATELY

Date: March 8, 2016

Subject: 14520A - Special Coverage  
Fractured Leaf Springs

Models: 2008-2009 Chevrolet Silverado LD  
2008-2009 GMC Sierra LD  
Currently Registered or Previously Registered in Maine,  
New Hampshire, New York, and Vermont and Canada

and

2007, 2010-2013 Chevrolet Silverado LD  
2007, 2010-2013 GMC Sierra LD  
Currently Registered or Previously Registered in Maine, New  
Hampshire, New York, and Vermont; New Brunswick, Newfoundland,  
Nova Scotia, Prince Edward Island, Ontario, and Quebec

To: All Chevrolet and GMC Dealers

This bulletin is being revised to add the 2007, and 2010-2013 model year Chevrolet Silverado and GMC Sierra light duty trucks, along with expanding coverage to certain U.S. States identified above. The total number of U.S. vehicles involved is approximately 163,697. Please see the attached bulletin for details.

**Customer Letter Mailing**

The customer letter mailing will begin the last week of March 2016.

**Global Warranty Management (GWM)**

The Investigate Vehicle History (IVH) screen in the GWM system will be updated March 11, 2016. Please hold all warranty transactions until the VIN appears in IVH.

END OF MESSAGE  
GLOBAL SAFETY FIELD INVESTIGATIONS