



**HYUNDAI**

NEW THINKING.  
NEW POSSIBILITIES.

## Technical Service Bulletin

GROUP <b>CAMPAIGN</b>	NUMBER <b>16-01-046</b>
DATE <b>NOVEMBER 2016</b>	MODEL(S) <b>SONATA (YF)</b>

**SUBJECT:** SONATA (YF) UNDERBODY CORROSION PREVENTATIVE SERVICE  
(SERVICE CAMPAIGN 946)

### ★ IMPORTANT

#### \*\*\* Retail Vehicles Only \*\*\*

Dealers must perform this Service Campaign whenever an affected vehicle is in the shop for any maintenance or repair.

When a vehicle arrives at the Service Department, access Hyundai Motor America's "Warranty Vehicle Information" screen via WEBDCS to identify open Campaigns.

**Description:** In some areas, a vehicle's underbody may exhibit corrosion due to road salt usage. As a precautionary measure, cavity wax coating is applied to the internal surfaces of underbody components, and an undercoating spray is applied to the bottom exterior surfaces of specified underbody components. This bulletin describes the procedure to perform this preventative service on certain Sonata (YF) vehicles.

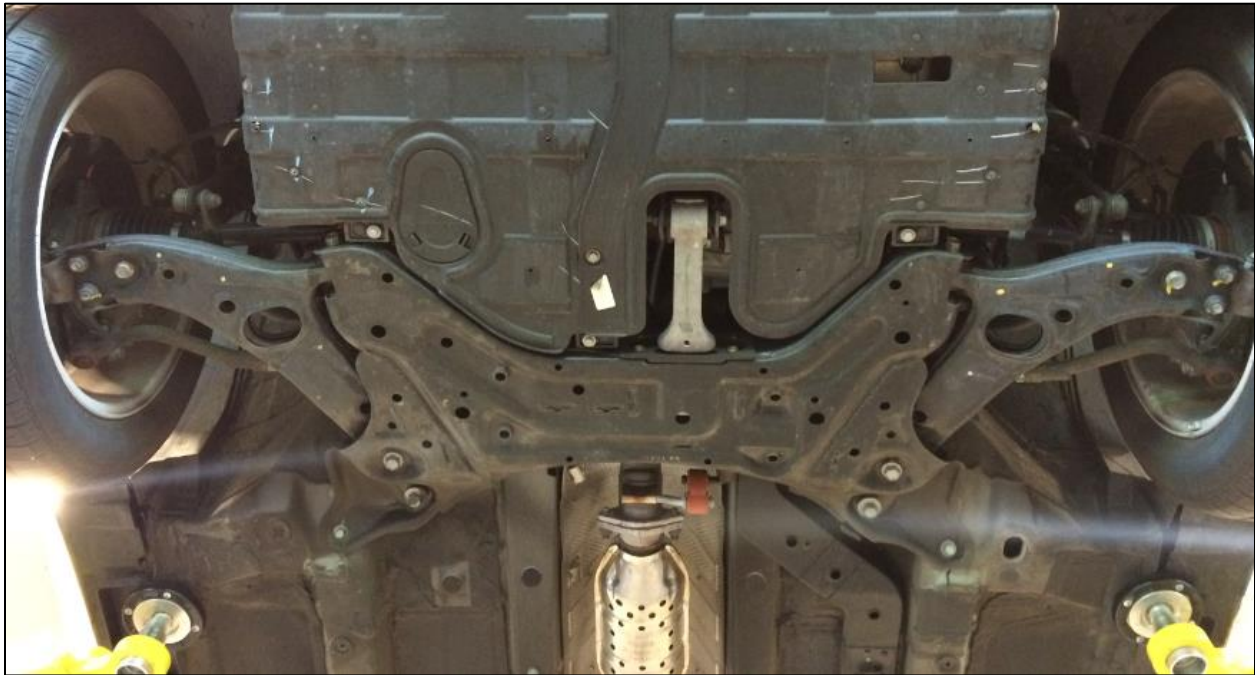

#### Applicable Vehicles:

**VERIFY THAT THE VEHICLE IS IDENTIFIED AS AFFECTED BY THE SERVICE CAMPAIGN VIA WEBDCS.**

- 1. Model:** 2011-2014MY Sonata (YFa)
- 2. Production Date Range:** From December 11, 2009 – May 29, 2014.
- 3. Areas:** Connecticut, Delaware, Illinois, Indiana, Iowa, Maine, Maryland, Massachusetts, Michigan, Minnesota, Missouri, New Hampshire, New Jersey, New York, Ohio, Pennsylvania, Rhode Island, Vermont, West Virginia, Wisconsin, and the District of Columbia

Circulate To: General Manager, Service Manager, Parts Manager, Warranty Manager, Service Advisors, Technicians, Body Shop Manager, Fleet Repair

**\* IMPORTANT**



There are circumstances under which vehicles not currently registered or have never been registered in a “salt belt” state may be eligible for this Campaign. These circumstances include:



Vehicles that have relocated into a “salt belt” area and/or vehicles registered in a “non-salt belt” state and driven in a “salt belt” area. If it is determined that an owner of a vehicle within the affected VIN production date range relocates or has operated their vehicle in a “salt belt” area, the dealer should perform the campaign procedure. The dealer should perform this procedure at no cost to the customer, and the Hyundai Warranty PA Center must be contacted prior to repair and submission of Warranty Claim.

**\* NOTE**

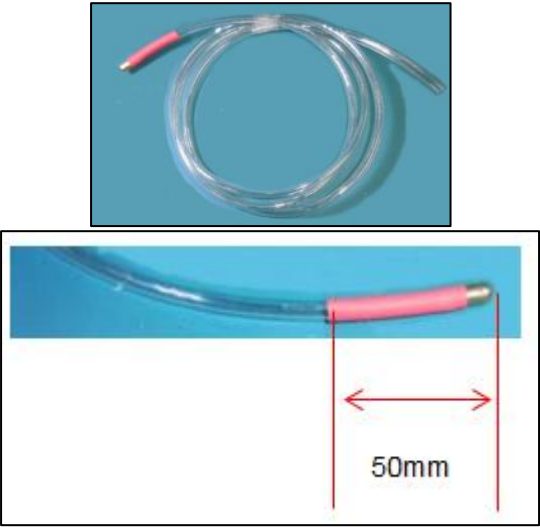

If the owner of a vehicle within the affected VIN production date range requests an undercarriage inspection of their vehicle, the inspection should be performed at no charge to the customer.

**Parts Information:**

Part Name	Image / Part Number	Remark
Cavity Wax		Use about half a can per vehicle.
	00232-19034	
Undercoat Spray		Use about 1 can per vehicle.
	00232-19035	
Wax Spray Gun		Regulate air pressure to 70 psi.  <b><i>If wax output is slow</i></b> , prime the gun by blocking the nozzle with a rag, and spraying the gun until the flow of wax increases.
	00232-19036	

<p>“Inside” Nozzle</p>		<p>This is a newly developed nozzle that has an improved wax application spray pattern.</p>  <p>The pink tubing is to signal the user to stop spraying when pulling the nozzle out.</p>
	<p>09624-2H101-QQH</p>	<p><u>This nozzle must be used for this service procedure.</u></p>
<p>“Outside” Nozzle</p>		<p>This nozzle is supplied with the wax gun.</p>

**Tools & Equipment Required:**

Tool Name	Image	Remark
<p>Air Nozzle</p>		
<p>Goggles</p>		<p><b>NOTICE</b></p> <p>Wear protective goggles and respiratory protection when performing the procedures in this bulletin.</p> <p>This procedure should be performed in a well-ventilated area.</p>
<p>Mask</p>		

Mallet		
Wire Brush		
Plastic bags		Trash bags large enough to cover wheel/tire assemblies.

**Warranty Information:**

Model	Op. Code	Operation	Op. Time
YF	60CA16R0	APPLYING CAVITY WAX & BLACK UNDER COAT TO THE UNDERBODY	0.7 M/H

**NOTE 1: Submit Claim on Campaign Claim Entry Screen.**

**NOTE 2: Each labor operation will reimburse applicable undercoating and cavity wax in sublet.**

**NOTE 3: If a part is found in need of replacement while performing Service Campaign 946, please submit a separate claim using the same Repair Order used for the Service Campaign.**

**Service Procedure Notes:**

1. When applying the cavity wax, the floor might be contaminated. It is recommended to put a plastic vinyl sheet on the floor before applying wax.



**2. Wax gun preparation:**

2a. Remove the compression fitting from the nozzle assembly that originally comes with the wax gun by unscrewing the nut, then removing the fitting from the tube.

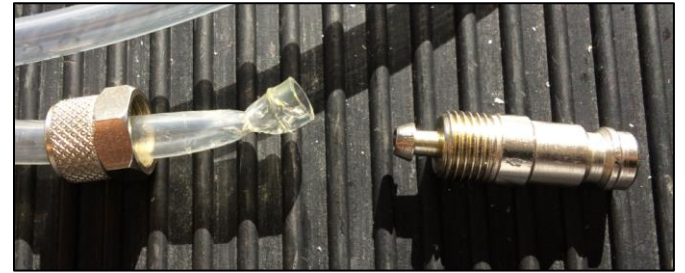
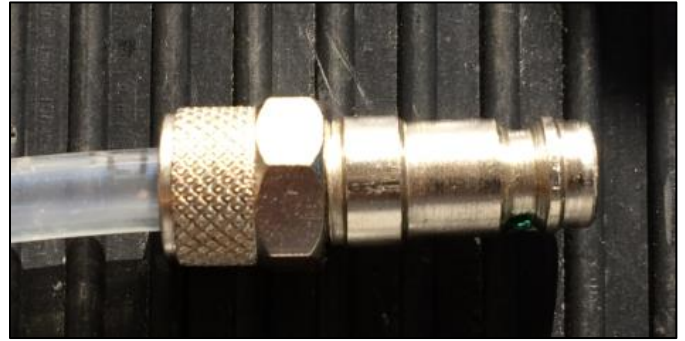

2b. Attach the compression fitting to the tubing on the new nozzle assembly.



2c. Fill wax gun reservoir with cavity wax.

Prime the wax gun by spraying into a trash bag (or similar) until a light mist is visibly coming out of the nozzle.

**NOTICE**

**Air supply pressure must be set to 70 psi.**



**NOTICE**

**If volume of wax coming out of the nozzle slows significantly (so that a light mist is no longer visible), prime the gun again.**

**It may speed the priming process to block the nozzle with a rag while spraying the gun until the flow of wax increases.**



**Service Procedure #1: Hammering and Air Blowing to Remove Debris**

**NOTICE**

There are 2 types of subframes, perimeter-frame and H-frame. The application of cavity wax and undercoating spray is slightly different for each type.

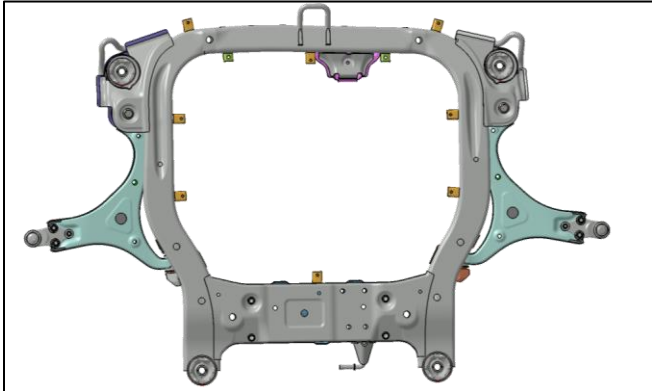
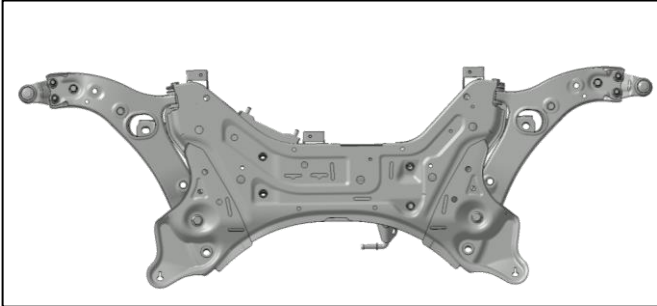
PERIMETER-FRAME	H-FRAME
 A 3D CAD model of a perimeter-frame subframe. It is a rectangular frame with four main vertical and horizontal members, and four diagonal members connecting the corners. The frame is light gray with some green and purple highlights on the suspension mounting points.	 A 3D CAD model of an H-frame subframe. It has a central horizontal member and two vertical members extending outwards, forming an 'H' shape. The frame is light gray with some green highlights on the suspension mounting points.

1. Lift the vehicle on a hoist.



2. Lightly tap the vehicle underbody with a 16 oz. hammer to loosen debris and the PVC coating in the following locations:

- Front lower control arms

**NOTICE**

If the vehicle has front lower control arms made of aluminum, no preventative maintenance procedures are required on the front lower control arms.



ALUMINUM



- Front cross member: Perimeter-frame



- Front cross member: H-frame

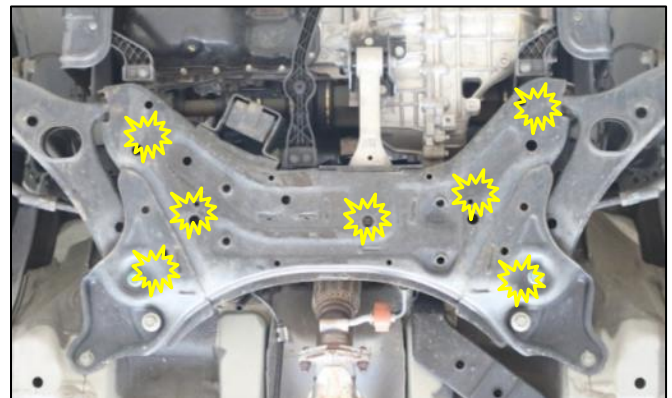



- Rear lower control arms and cross member

**NOTICE**

If the vehicle has rear lower control arms made of aluminum, no preventative maintenance procedures are required on the rear lower control arms.

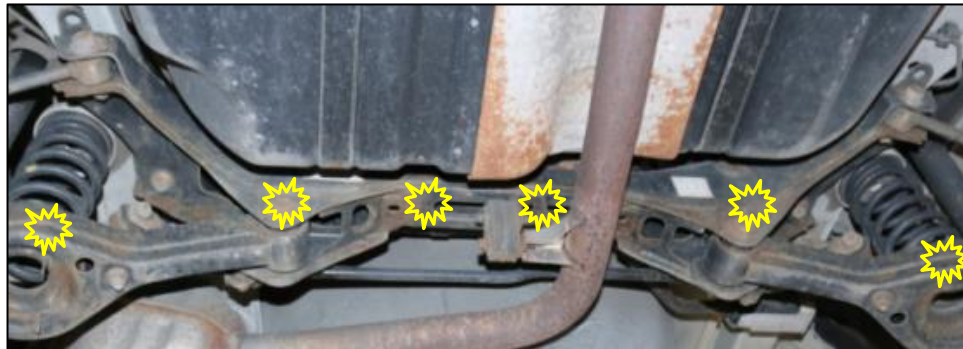

3. Remove the remaining debris by inserting an air nozzle into the locations shown, then blowing air in multiple directions.



- **Perimeter-frame:** Front lower control arms

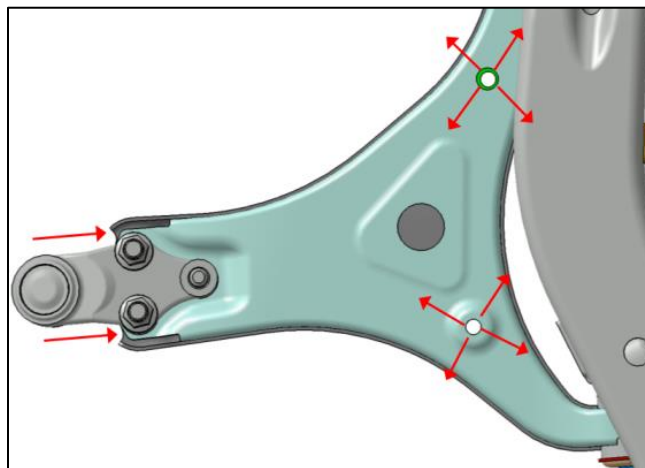
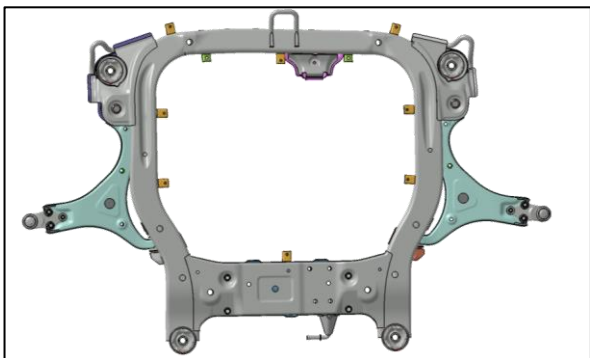

- **Perimeter-frame:** Front cross member

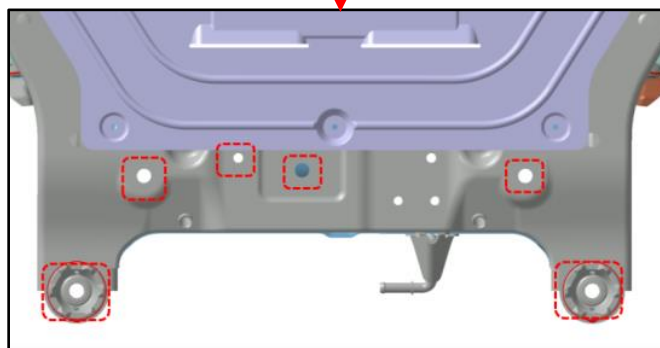
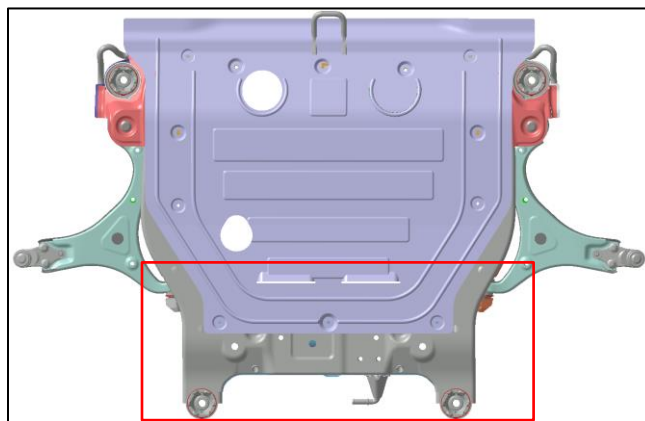

- **H-frame:** Front lower control arms

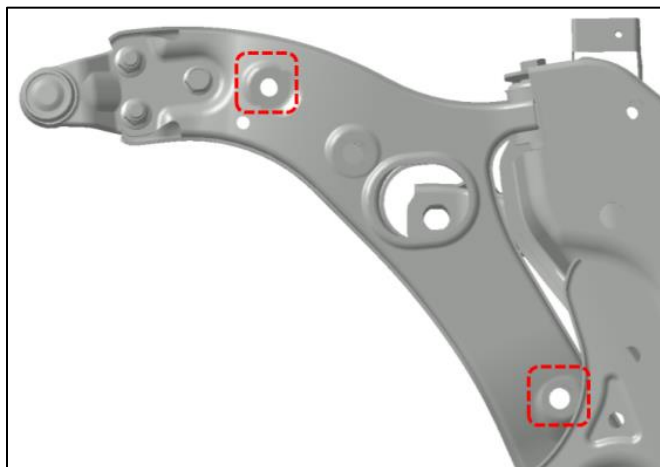
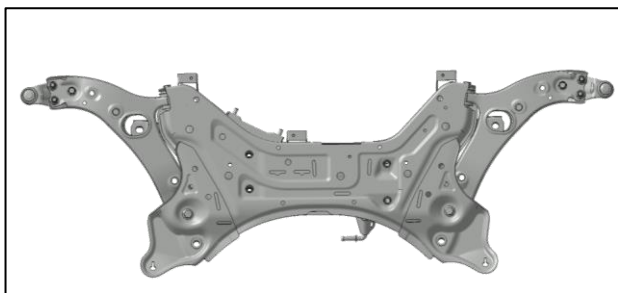

- **H-frame:** Front cross member

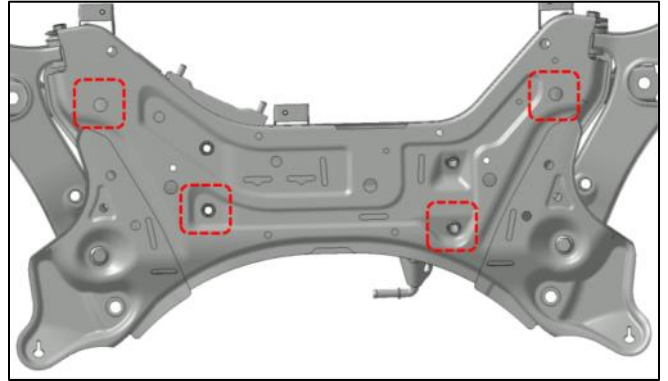

- Rear cross member



- Rear upper arms

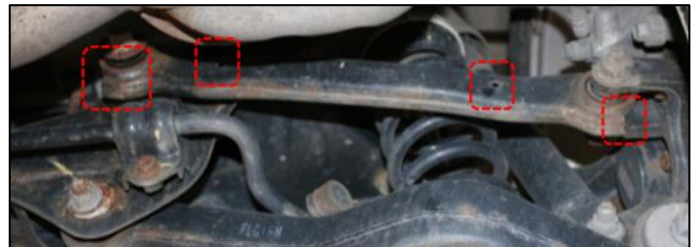

- Rear lower control arms

**NOTICE**

If the vehicle has rear lower control arms made of aluminum, no preventative maintenance procedures are required on the rear lower control arms.

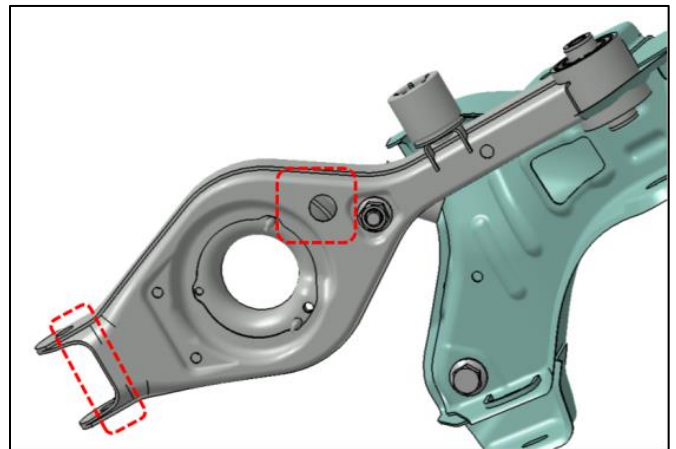

**Service Procedure #2: Preparation for Cavity Wax and Undercoating Spray**

1. Clean the brake banjo bolt surfaces at all 4 calipers using a wire brush. Then wrap the brake assemblies with plastic bags to protect them from overspray. Use tape to secure the plastic in place. Leave the banjo fitting area exposed, as shown.

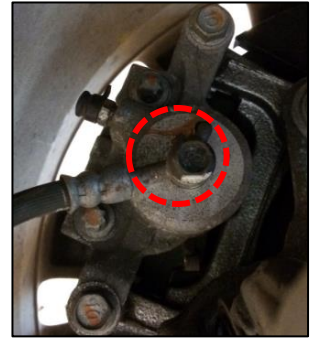
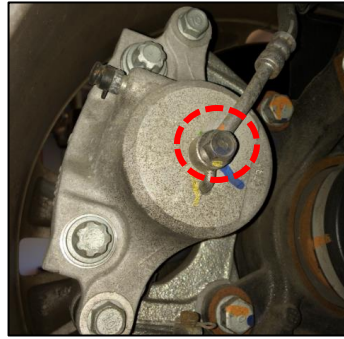

2. Wrap large plastic bags around the wheel/tire/brake assemblies to protect them from overspray. Use tape to secure the plastic in place.



3. Wrap the exhaust areas adjacent to the front and rear cross members with plastic bags to protect them from overspray. Use tape to secure the plastic in place.

**NOTICE**

The exhaust must be sufficiently cooled before it is wrapped.



Exhaust near front cross member



Exhaust near rear cross member

**Service Procedure #3: Applying the Cavity Wax**

**CAUTION**

**Wear protective goggles and respiratory protection when performing the procedures in this bulletin. The vehicle should be in a well-ventilated area.**

Apply the cavity wax at each of the locations noted in the following steps.

Generally for coating interior surfaces, insert the “inside” nozzle as deeply as possible at each point of entry. Spray the cavity wax while simultaneously rotating the nozzle, and slowly pulling the nozzle out. Continue this rotating/pulling motion until the pink tubing is seen coming out of the hole. The pink tubing indicates there is about 50mm of tubing left until the end of the nozzle. Stop spraying when the pink tubing is seen.

Generally for coating exterior surfaces, use the “outside” nozzle, provided with the wax gun.

1a. **Perimeter-frame:** Front cross member – Interior surfaces (using **“outside”** nozzle)

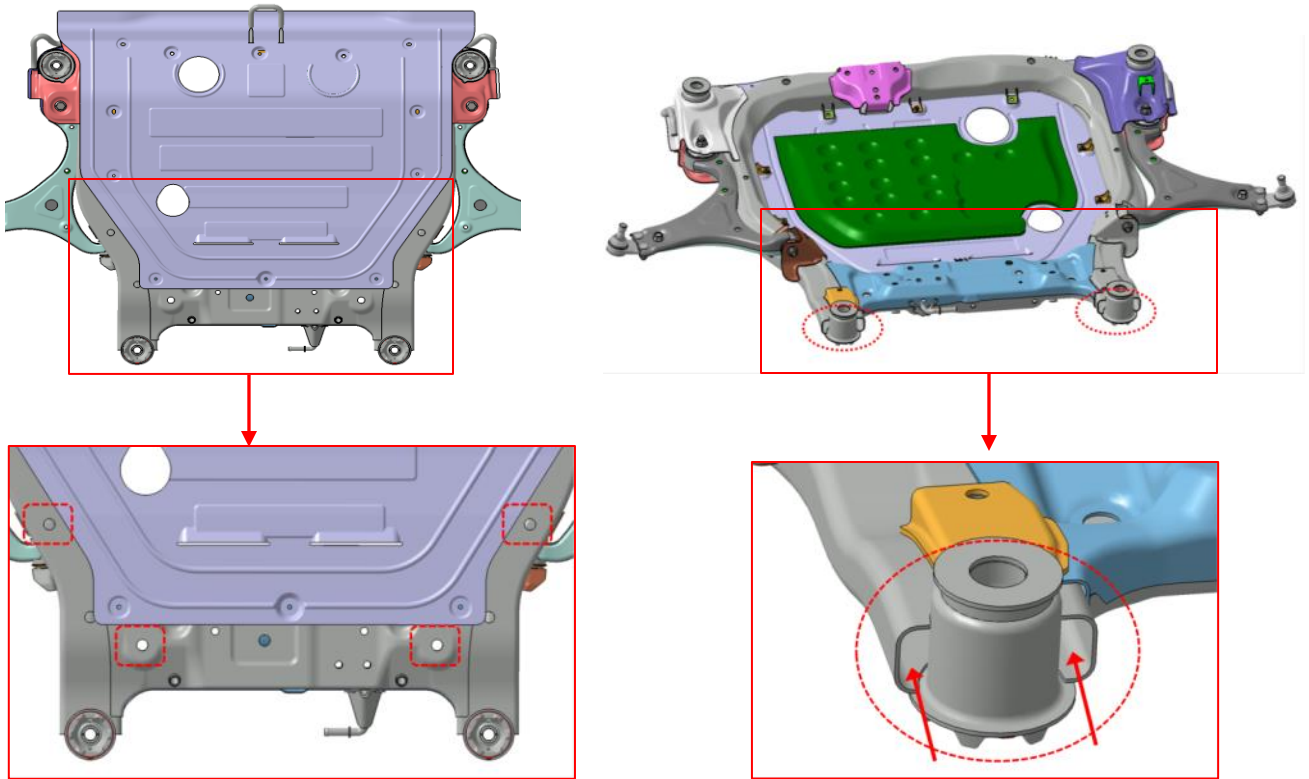

**Perimeter-frame:** Front lower control arms – Interior surfaces (using **“inside”** nozzle)

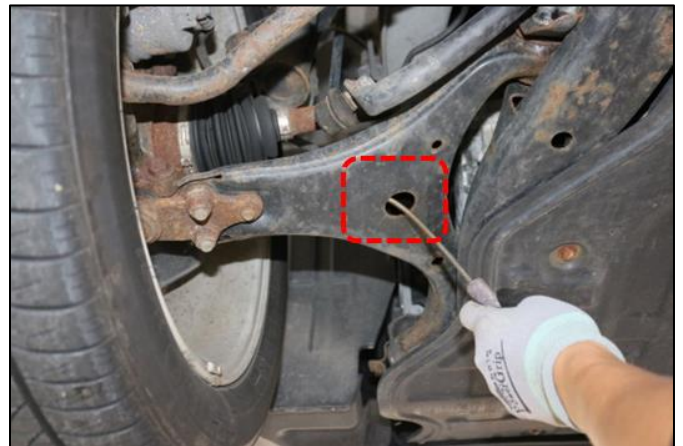

1b. **H-frame:** Front cross member – interior surfaces (using **“inside”** nozzle)

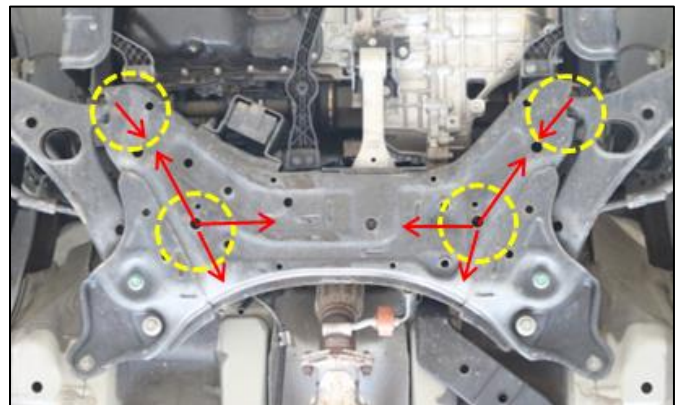

**H-frame:** Front lower control arms – interior surfaces (using “*inside*” nozzle)



2. Rear cross member – Interior surfaces (using “*inside*” nozzle)



3. Rear lower control arms – Interior surfaces (using “*inside*” nozzle)

**NOTICE**

If the vehicle has rear lower control arms made of aluminum, no preventative maintenance procedures are required on the rear lower control arms.

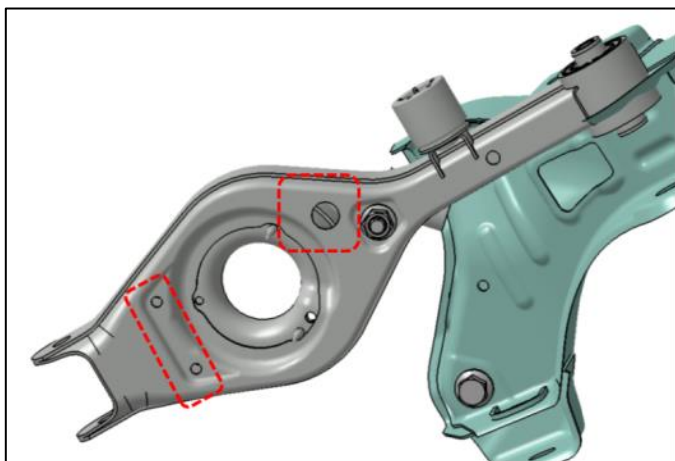

4. Rear upper control arms – Interior surfaces using “*outside*” nozzle

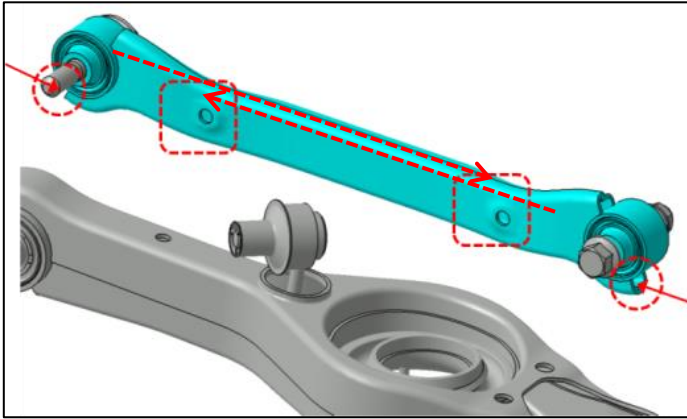

**Service Procedure #4: Applying the Undercoating Spray**

**⚠ CAUTION**

Wear protective goggles and respiratory protection when performing the procedures in this bulletin. The vehicle should be in a well-ventilated area.

Spray the black undercoating on all exterior surfaces of the front and rear cross members, front and rear lower arms, rear upper arms, front and rear brake hose mounting points, and the fuel & brake tubes. Refer to the following images.

- 1a. **Perimeter-frame:** Front cross member





- 1b. **H-frame:** Front cross member



2. Front lower control arms

**NOTICE**

If the vehicle has front lower control arms made of aluminum, no preventative maintenance procedures are required on the front lower control arms.



3. Rear cross member



4. Rear upper arms



5. Rear lower arms

**NOTICE**

If the vehicle has rear lower control arms made of aluminum, no preventative maintenance procedures are required on the rear lower control arms.



6. Front and rear brake banjo fittings and mounting brackets.

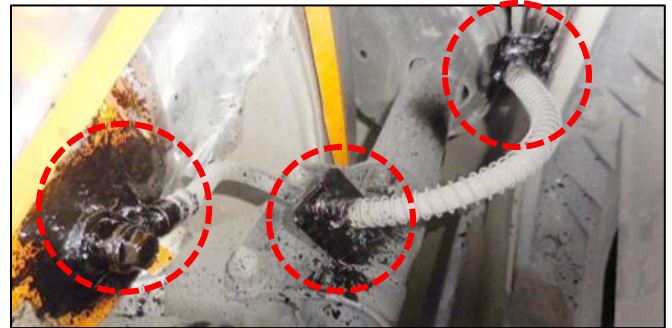
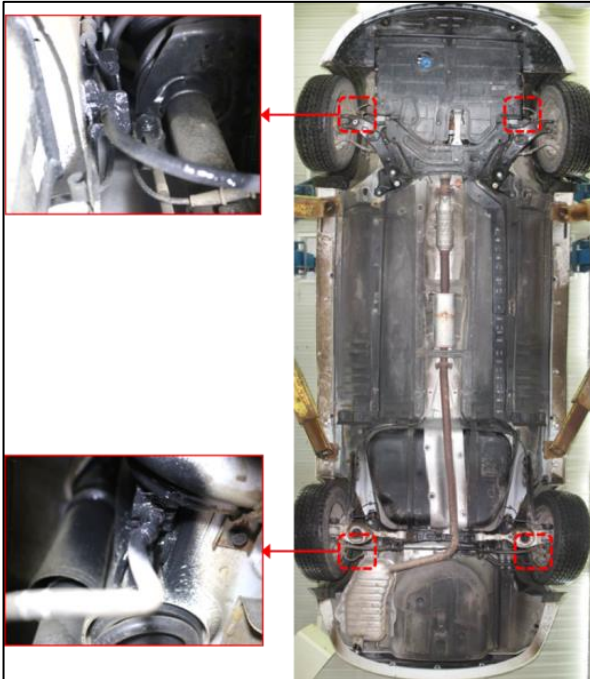

7. Fuel and brake lines.



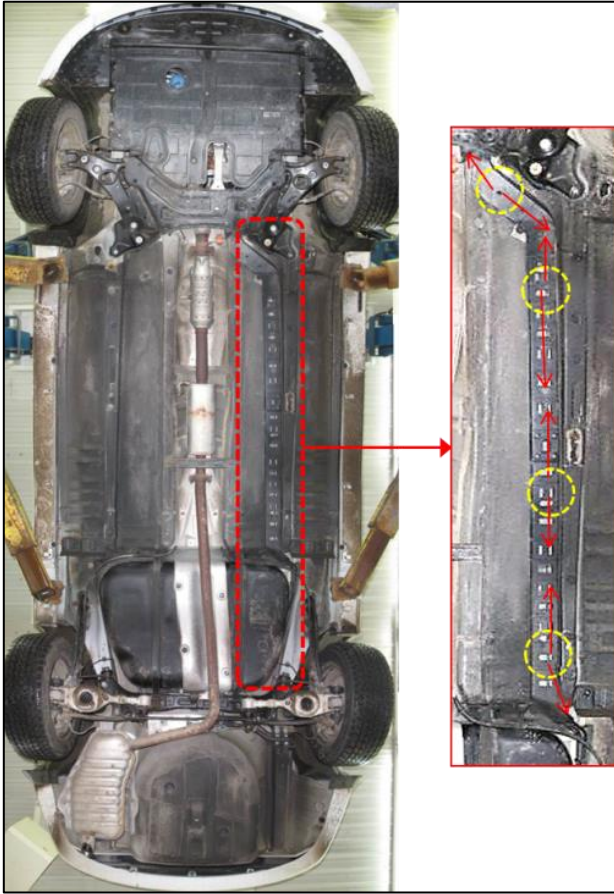

8. Remove all the plastic bags to complete the procedure.