



**HYUNDAI** | NEW THINKING.  
NEW POSSIBILITIES.

## Technical Service Bulletin

<b>GROUP</b> <b>RECALL</b>	<b>NUMBER</b> 16-01-075
<b>DATE</b> DECEMBER 2016	<b>MODEL(S)</b> SANTA FE (NC) TUCSON (TL)

**SUBJECT: SANTA FE (NC) TUCSON (TL) TOW HITCH HARNESS REPLACEMENT  
(RECALL CAMPAIGN 153)**

### ★ IMPORTANT

**\*\*\* Dealer Stock and Retail Vehicles \*\*\***

Dealers must perform this Recall Campaign on all affected vehicles prior to customer retail delivery and whenever an affected vehicle is in the shop for any maintenance or repair.

When a vehicle arrives at the service department, access Hyundai Motor America's "Warranty Vehicle Information" screen via WEBDCS to identify open Campaigns.

**Description:** The 2017 Santa Fe (NC) and 2016 – 2017 Tucson (TL) are available with a Genuine Hyundai trailer hitch and wiring harness. On certain units, when the trailer's lighting wiring harness is connected to the vehicle, the tow hitch module may malfunction resulting in continuous illumination of the trailer's brake and/or turn signal bulb(s). **This condition affects only the trailer's lighting; not the vehicles.** If a vehicle equipped with the Genuine Hyundai accessory tow package is driven with a trailer, it is possible that the trailer lights would be unable to comply with Federal Motor Vehicle Safety Standards. A failure to notify other vehicles of the driver's intent could potentially increase the risk of a crash.





**2017 Santa Fe(NC)**



**2016-2017 Tucson(TL)**

**Applicable Vehicles: Certain 2017 Santa Fe(NC) and 2016 – 2017 Tucson(TL) with port, dealer or customer installed tow hitch and harness.**

**Parts Information:**

PART NAME	VEHICLE	PART NO.	IMAGE
TOW HARNESS	SANTA FE(NC)	B8161 ADUS6 QQH	
TOW HARNESS	TUCSON(TL)	D3061 ADUS6 QQH	

**Warranty Information:**

MODEL	OP CODE	OPERATION DESCRIPTION	OP TIME	CAUSAL PART	NATURE CODE	CAUSE CODE
TL	TOWHIT10	Inspect Hitch – No Genuine Tow Hitch Installed	0.2	D3061 ADUS6 QQH	B15	ZZ3
NC	TOWHIT11	Inspect Hitch – No Genuine Tow Hitch Installed	0.2	B8161 ADUS6 QQH	B15	ZZ3
TL	TOWHIT12	Inspect Harness - Date Code OK	0.3	D3061 ADUS6 QQH	B15	ZZ3
NC	TOWHIT13	Inspect Harness - Date Code OK	0.3	B8161 ADUS6 QQH	B15	ZZ3
TL	TOWHITR0	Inspect & Replace Harness	1.1	D3061 ADUS6 QQH	B15	ZZ3
NC	TOWHITR1	Inspect & Replace Harness	0.5	B8161 ADUS6 QQH	B15	ZZ3

**NOTE: Submit Claim on Campaign Claim Entry Screen.**

**Service Procedure:**

**INSPECT HITCH – NO GENUINE TOW HITCH INSTALLED (SANTA FE[NC]/TUCSON[TL])**

1. Locate the part number stamping on the driver side mounting bracket, outboard surface.

TIP: It may be helpful to have a flashlight and shop rag when inspecting the part.

Santa Fe(NC)







Tucson(TL)

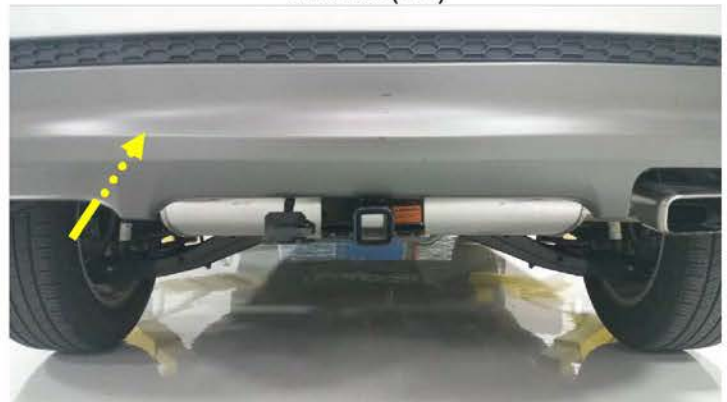

2. If the stamping indicates a production date in YYDDD format (ex. "15141"), and the tow hitch's part number is:

Santa Fe(NC): B8161 ADU0x

Tucson(TL): D3061 ADU0x

"x" may be any number, sequentially starting with zero (0), for example B8161 ADU00 or B8161 ADU01.

Proceed to "Inspect Harness Procedure", for the respective vehicle.

If the part does not have the stamping, it is not a genuine part. No further action is needed.

Use OP CODE TOWHITI0 for Tucson (TL)  
Use OP CODE TOWHITI1 for Santa Fe (NC)

**FINISH**



**INSPECT HARNESS PROCEDURE (SANTA FE[NC])**

1. Position the vehicle on the lift.

Open the liftgate and lower the spare tire.



2. Prior to disconnecting the negative (-) battery cable, note the AM/FM and satellite radio frequencies (if applicable).

Open the hood and disconnect negative (-) battery cable.

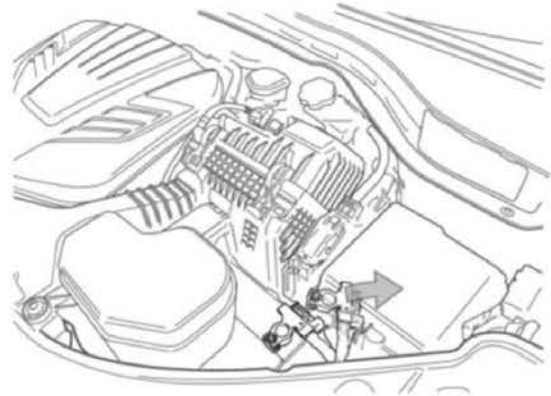

3. Lift the vehicle, remove the spare tire and set aside.

4. Remove the vehicle aero undercover and three fasteners behind the Driver's side rear wheel, inside the rear bumper corner.

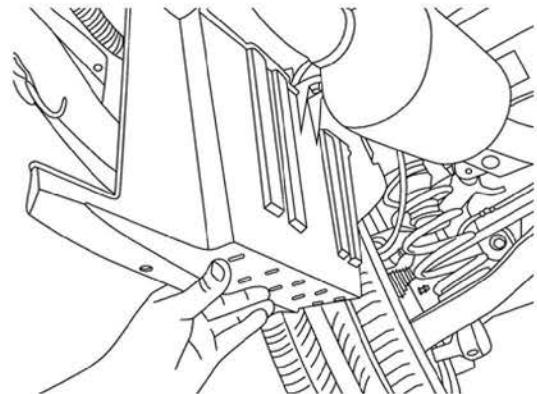

5. Harness Type 1: Look for the tow hitch harness part label behind the aero Undercover. If not present, check Harness Type 2 location below.

If the Julian date code indicated on the harness reads 15335 through 16260, the harness must be removed. Proceed to Step 9.

If the Julian code is outside of that range, proceed to Step 6.

or

Harness Type 2: Look for the tow hitch harness part label above the tow hitch, behind the rear bumper fascia. If not present, proceed to Step 9.

If the Julian date code indicated on the harness reads 15335 through 16260, the harness must be removed. Proceed to Step 9.

If the Julian code is outside of that range, proceed to Step 6.

6. Reinstall the vehicle aero undercover behind the Driver's side rear wheel with the three (3) push fasteners.

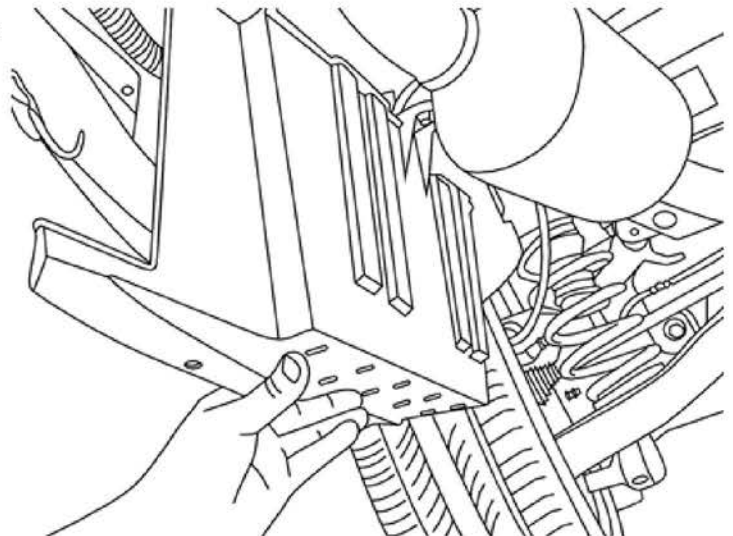



7. Reinstall the spare tire onto the spare tire hanger.

Lower the vehicle.

Raise the spare tire into it's storage position.

Tighten the spare tire hanger bolt.

Replace the spare tire hanger bolt cover.

Replace vehicle lug nut wrench.

8. Reconnect the vehicle's negative battery cable.  
Torque to: 3.93 N.m (0.40 Kgf.m, 34.8 lb-in)

Reprogram any pre-set radio stations (if applicable).

Close hood.

Close liftgate.

Use OP CODE TOWHIT3.

**FINISH**

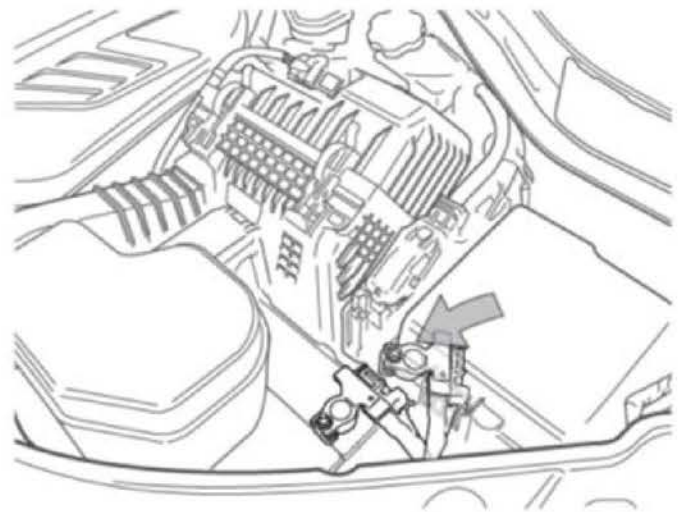

### **REMOVE HARNESS PROCEDURE (SANTA FE[NC])**

9. Disconnect the harness from the two (2) vehicle connectors behind the driver's rear wheel.

Cut all the securing zip ties attaching the tow hitch harness to the vehicle.

Note the location of the zip ties when removing them so they are installed in the same locations

Pull the module off the rear bumper.



Push the 4pin connector out of the securing

bracket on the hitch.

Let the harness hang over the bumper.

When installing the replacement harness.

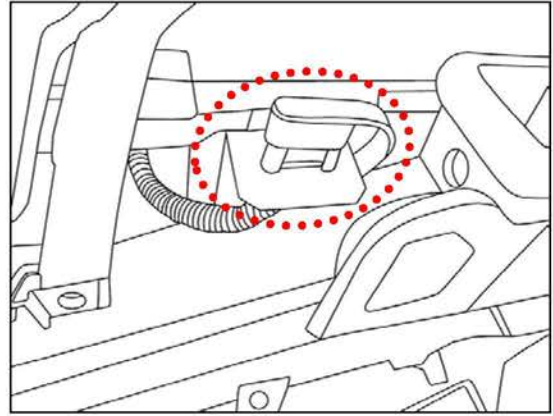

10. Pull the harness over the bumper toward the center of the vehicle and remove it from the vehicle.



11. Cut the 4-pin towing connector off the harness.





**REINSTALL HARNESS PROCEDURE (SANTA FE[NC])**

12. As shown, loosely install one (1) 8" cable tie into the tow hitch wire harness with a 1" diameter loop.

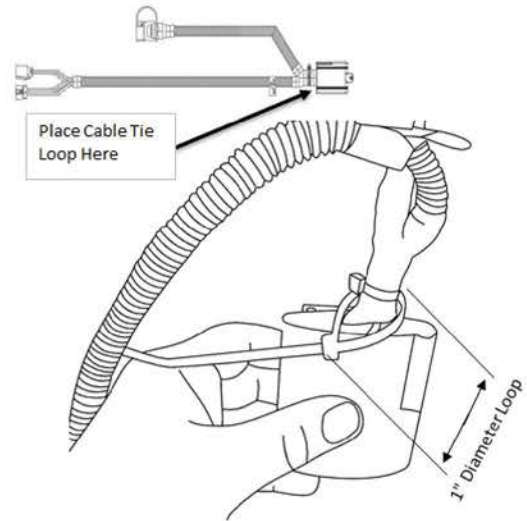

13. Locate the metal tab above the rear bumper beam to mount the tow hitch wire harness module.

Clean the mounting surface with 50/50 isopropyl alcohol (70%) and a clean cloth. Allow to fully dry.

Using one (1) 15" cable tie, insert the cable tie through the hole in the metal tab as shown.

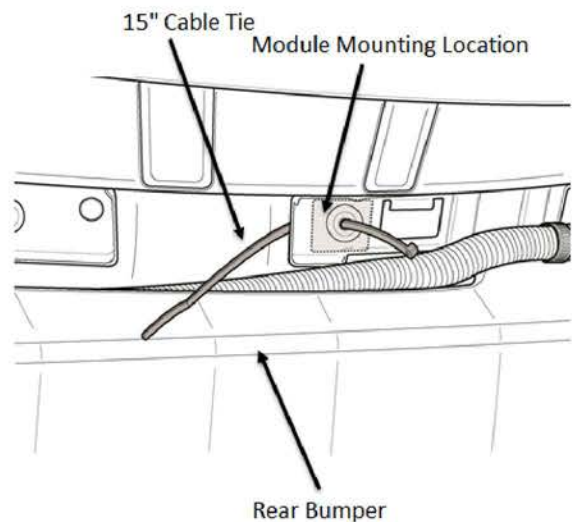

14. Remove the back liner of the foam adhesive tape that is applied to the backside of the tow hitch harness module.

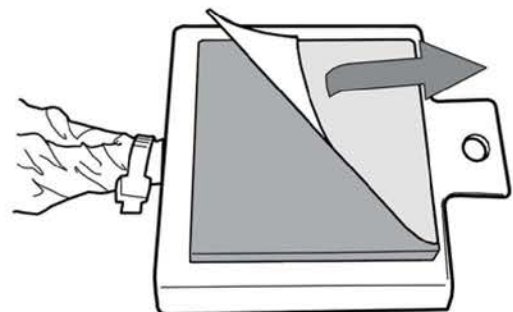

15. Loosely insert the 15" cable tie from step 13 into the hole of the tow hitch wiring module tab and then through the 8" cable tie loop.

With the cable tie looped around the module, firmly press the tow hitch wiring module onto the metal tab to adhere the adhesive tape and then tighten the two (2) cable ties. Trim excess cable tie material.

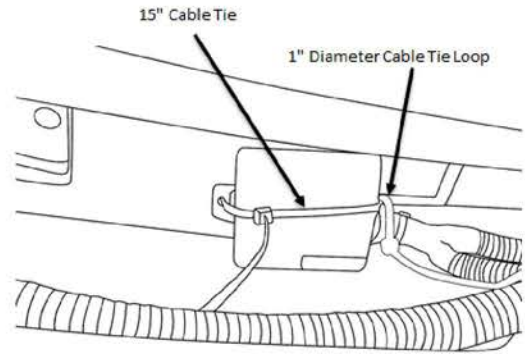

16. Route the 4-Flat harness straight down.

Using one (1) 8" cable tie, secure the tow hitch wire harness and the 4-Flat wire harness to the plastic bumper beam harness clip hole or to the OE backup sensor harness (if present). The distance between the 4-Flat connector and cable tie will be 12". Trim excess cable tie material.

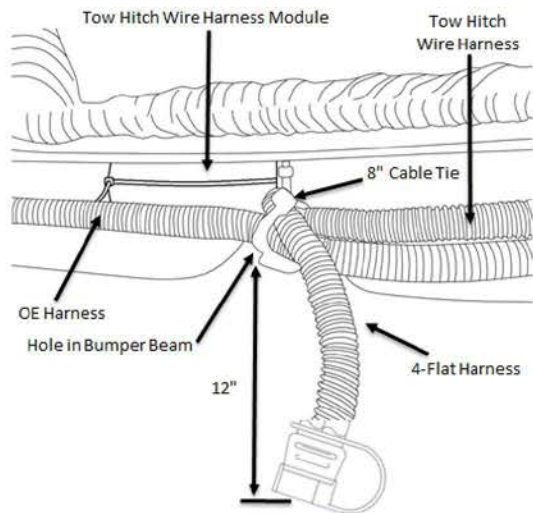

17. Route the tow hitch wire harness branch along the inside of the rear bumper and behind the bumper beam as shown.

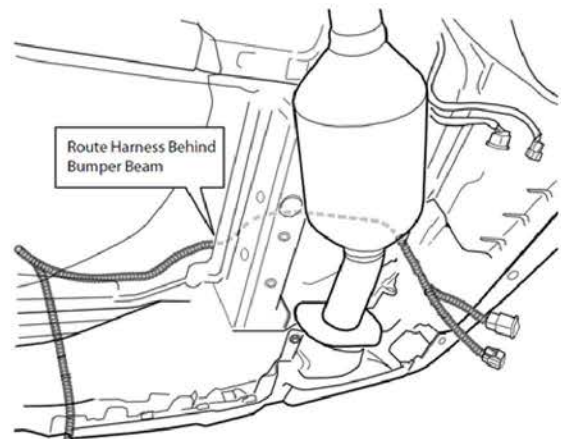

18. Install one (1) 8" cable tie around the tow hitch wire harness to the driver side reflector mounting bracket, as shown.

If present, route the harness behind the OE backup sensor harness as shown. Trim excess wire tie material.

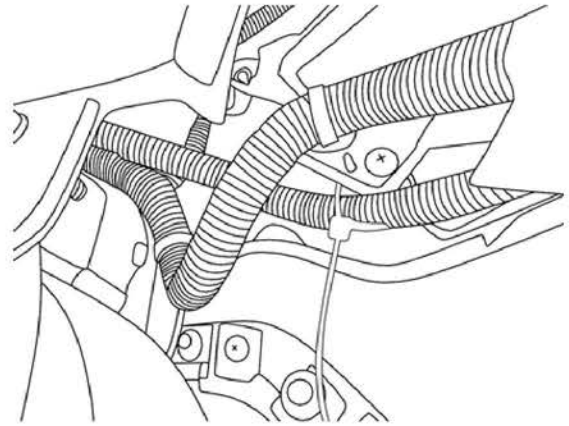

- 19a. *For vehicles WITHOUT BACKUP SENSORS*

Connect both tow hitch wire harness connectors to the vehicle connectors as shown. Use one (1) 8" cable tie to secure the tow hitch wire harness to the vehicle mounting locations as shown. Trim excess wire tie material.

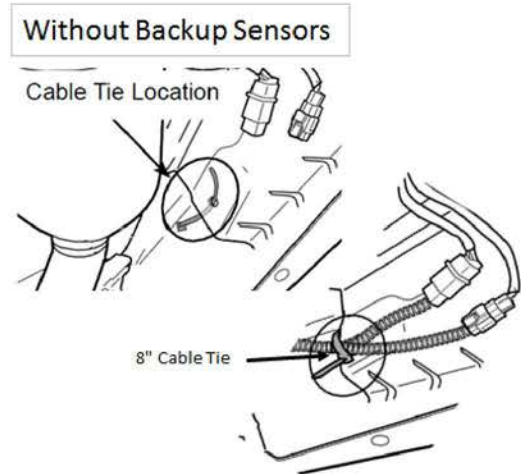

- 19b. *For vehicles WITH BACKUP SENSORS*

Connect both tow hitch wire harness connectors to the vehicle connectors as shown. Use one (1) 8" cable tie to secure the tow hitch wire harness to the backup sensor harness as shown. Trim excess wire tie material.

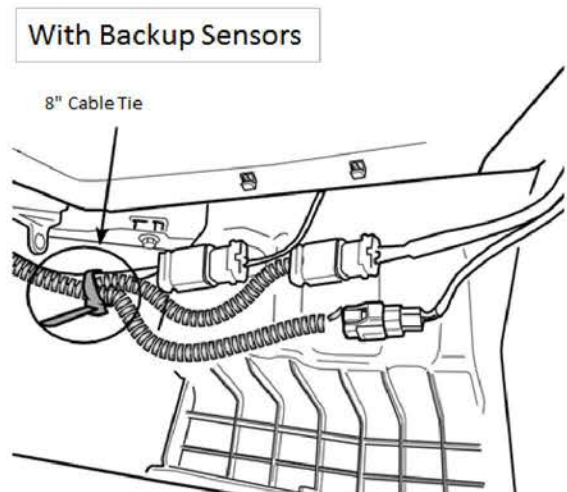



20. With the ground stud oriented to the driver side of the vehicle, push the 4-flat connector through the mounting bracket welded to the tow hitch until the first rubber detent is visible and is firmly locked into position. Secure the weather cap over the 4-Flat connector.

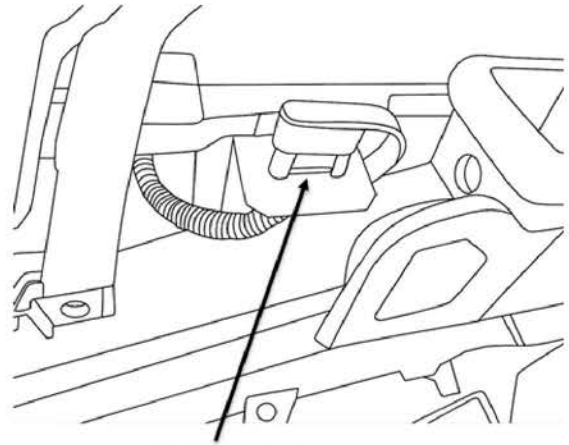

Visible Rubber Detent

21. Reinstall the vehicle aero undercover behind the Driver's side rear wheel with the three (3) push fasteners.

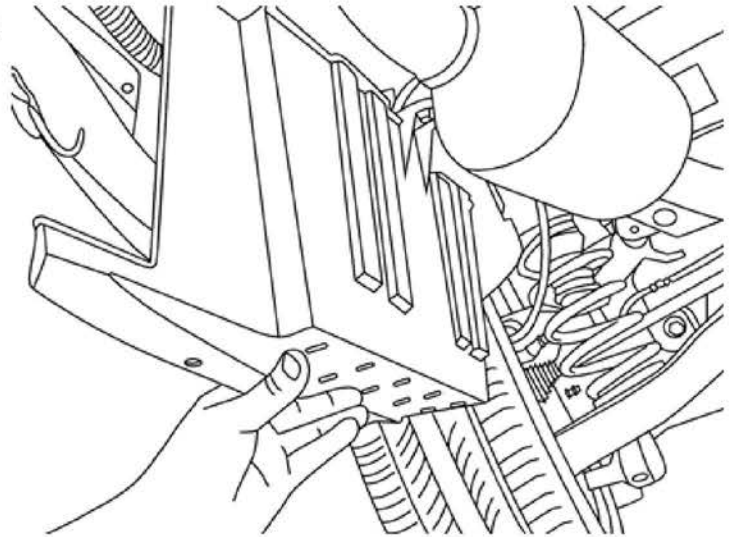

22. Reinstall the spare tire onto the spare tire hanger.

Lower the vehicle.

Raise the spare tire into it's storage position.  
Tighten the spare tire hanger bolt and replace vehicle lug nut wrench.

Replace the spare tire hanger bolt cover.

23. Reconnect the vehicle's negative battery cable.  
Torque to: 3.93 N.m (0.40 Kgf.m, 34.8 lb-in)

Close hood.

Reprogram any pre-set radio stations (if applicable).

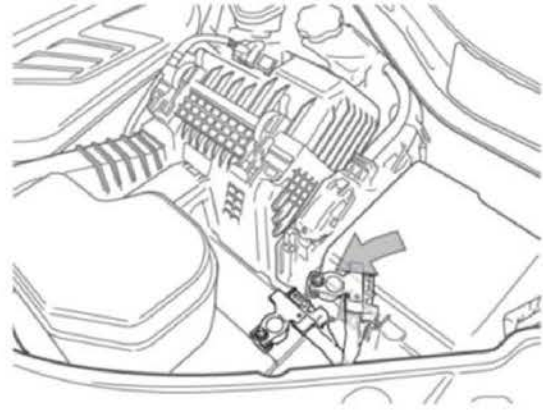

24. Perform Function Check found on page 48.

**NOTE:** This may require a 2<sup>nd</sup> person to assist.

Close lift gate.

Use OP CODE TOWHITR1.

**FINISH**

**INSPECT HARNESS PROCEDURE (TUCSON[TL])**

1. Position the vehicle on a lift and open the liftgate.

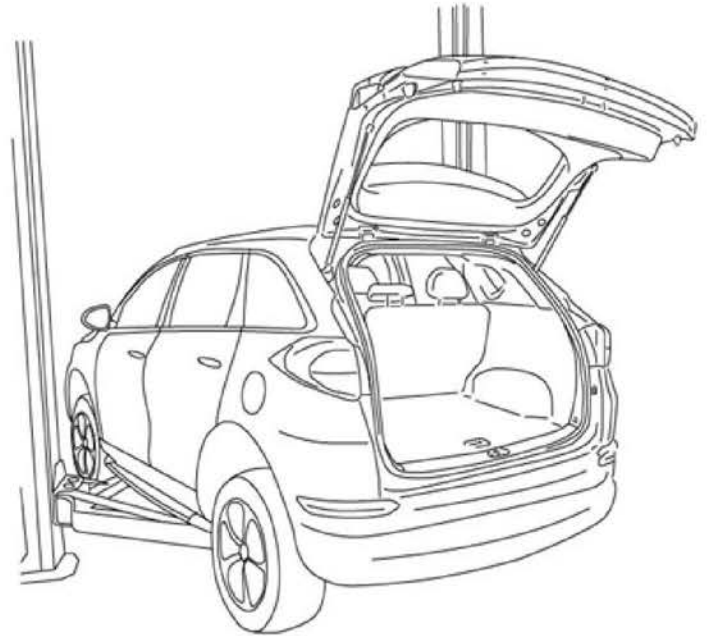

2. Prior to disconnecting the negative (-) battery cable, note the AM/FM and satellite radio frequencies (if applicable).

Open the hood and disconnect negative (-) battery cable.

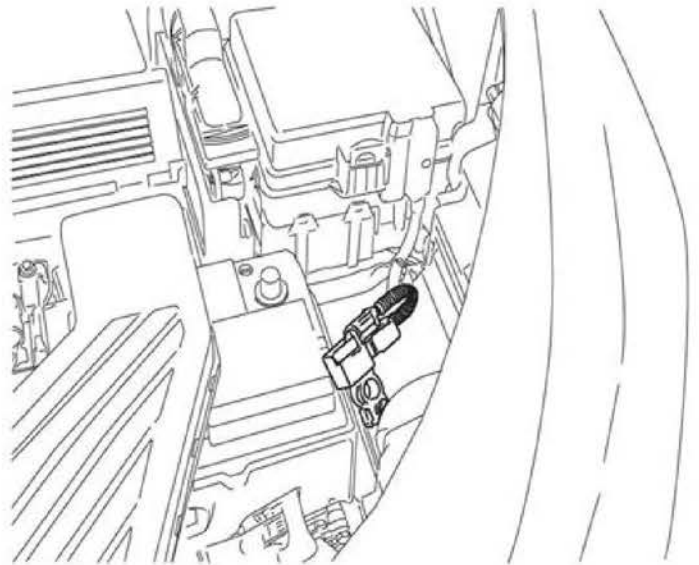



- 3. Lift the vehicle.



- 4. Remove the five (5) 10mm bolts securing the plastic cover to the underside of the vehicle as shown.

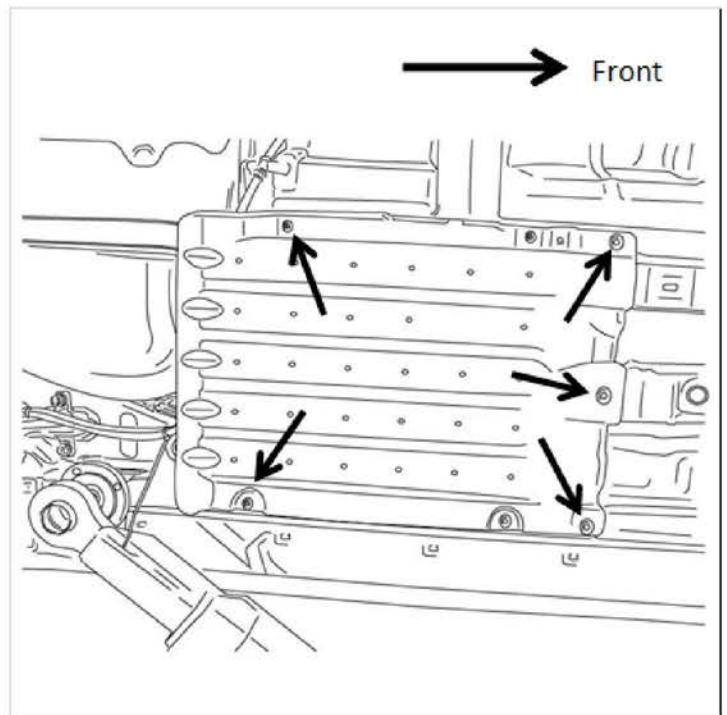

5. Inspect the tow hitch harness part label, if visible. If not present, proceed to Step 9.

**NOTE:** It may be necessary to cut the cable tie securing the harness to the brake line bracket, to see the label.

If the Julian date code indicated on the harness reads 15335 through 16260, the harness must be removed. Proceed to Step 9.

If the Julian code is outside of that range, proceed to Step 6.

**NOTE:** Be sure to check the rear wire harness label, not the front label.



- 6. Reinstall the plastic cover and five (5) 10mm bolts.

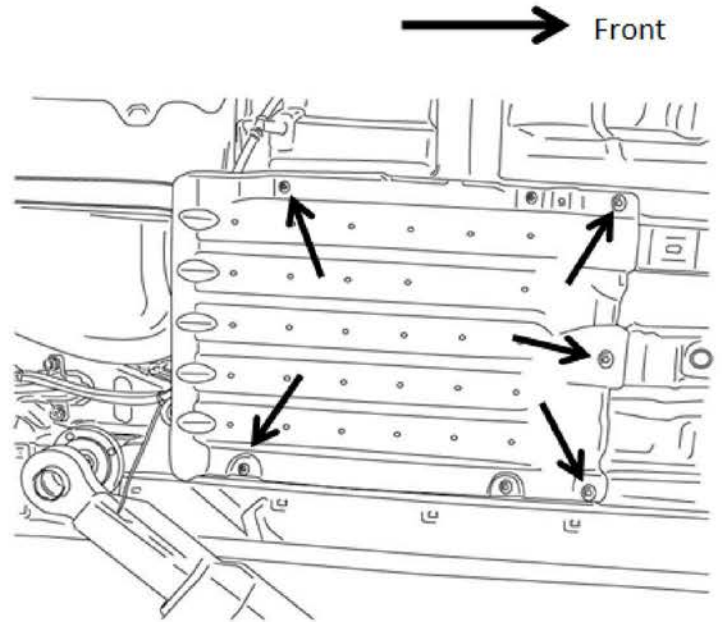

- 7. Lower vehicle.

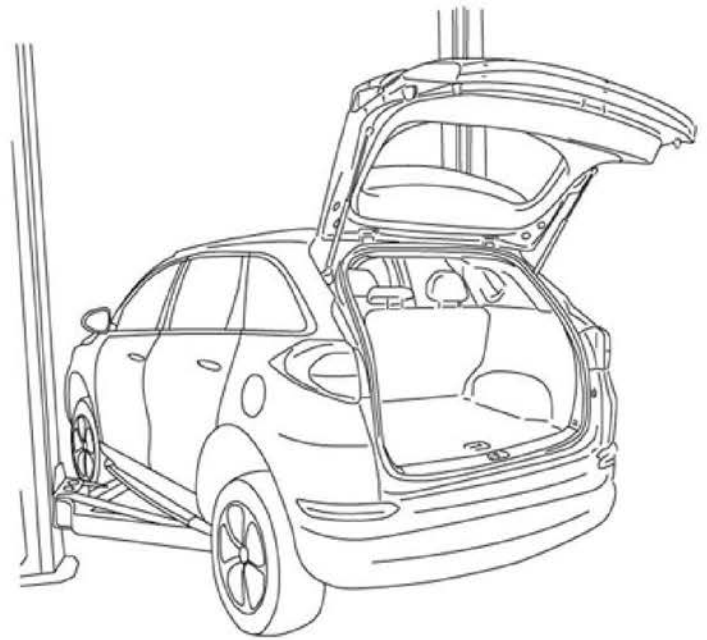



8. Reconnect the vehicle's negative (-) battery cable and torque to:  
3.93 N.m (0.40 Kgf.m, 34.8 lb-in)

Close the hood.

Close Liftgate.

Reprogram any pre-set radio stations (if applicable).

Use OP CODE TOWHIT2.

**FINISH**

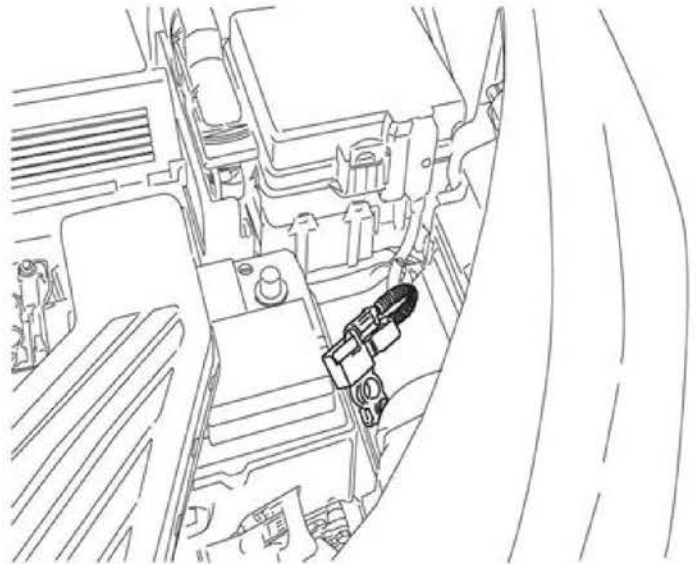

**REMOVE HARNESS PROCEDURE (TUCSON[TL])**

9. Remove the three (3) plastic clips, then dislodge and remove the driver side plastic undercover.

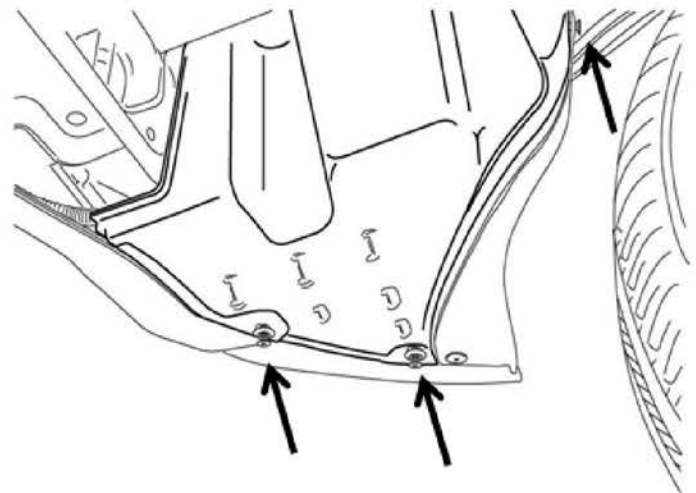

10. Remove the three (3) plastic clips, then dislodge and remove the passenger side plastic undercover.

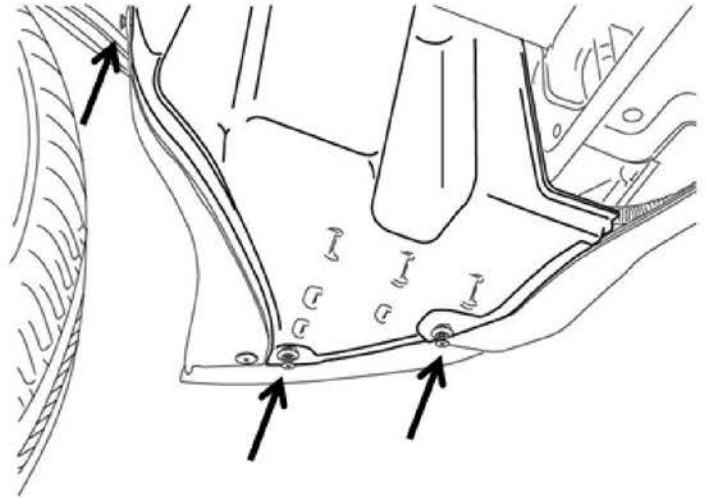

11. Disconnect the tow harness from the battery harness connection at the vehicle under cover.

Cut all the securing zip ties attaching the tow hitch harness to the vehicle from the connector back to the area of the rear aero undercover.

Dislodge the push-type zip tie from the vehicle body.

Cut all the securing zip ties attaching the harness along the rear bumper to both rear taillights.

Push the 4-Flat connector out of the securing bracket on the hitch.

Pull the power connector that was previously disconnected, rearward towards the area behind the driver rear wheel.

Let the 4-Flat towing harness branch hang down.

12. Lower the vehicle.

Flip down the driver rear seat back.

**NOTE:** Ensure the tow hitch harness does not get caught under the tire when lowering the vehicle.

13. Remove the cargo floor panel, and retractable cargo cover, if equipped.

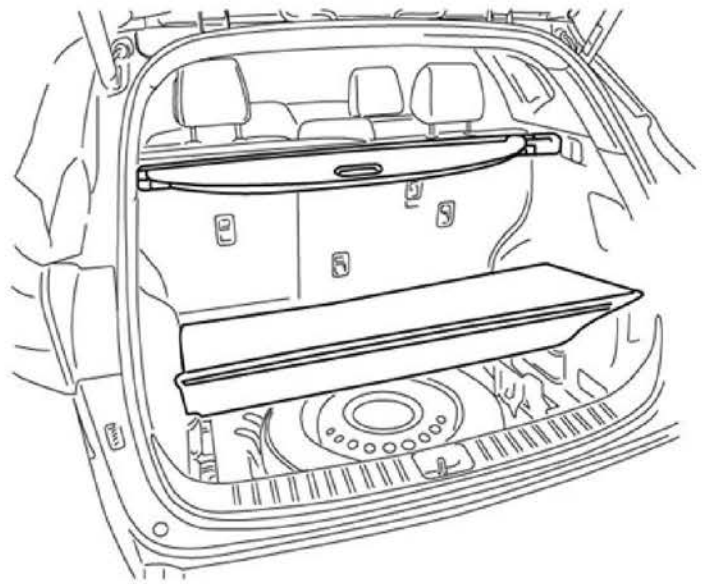

14. Remove the two (2) Philips head plastic clips securing the rear threshold panel.

Remove the rear threshold panel.

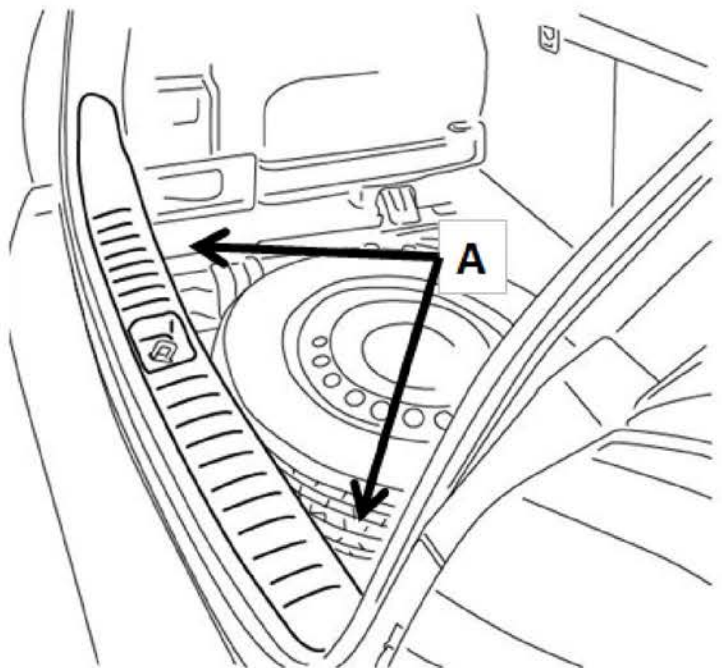



15. Remove the two (2) screws securing the driver side rear interior side lining panel.

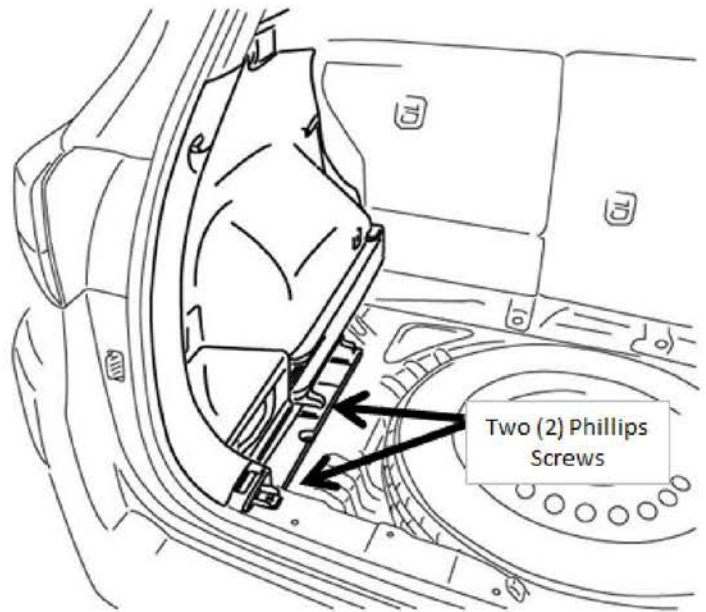

16. Dislodge the lift gate rubber weatherstrip along the driver side.

Dislodge the driver side rear interior side lining panel. It is not necessary to remove the panel completely.

**CAUTION:** Black sealant will be exposed. Do not get the sealant on yourself or the vehicle.

**NOTE:** Do not damage the retention clips (A) when dislodging the panel.

**TIP:** It may be useful to use the replacement tow hitch harness box to prop the panel open.

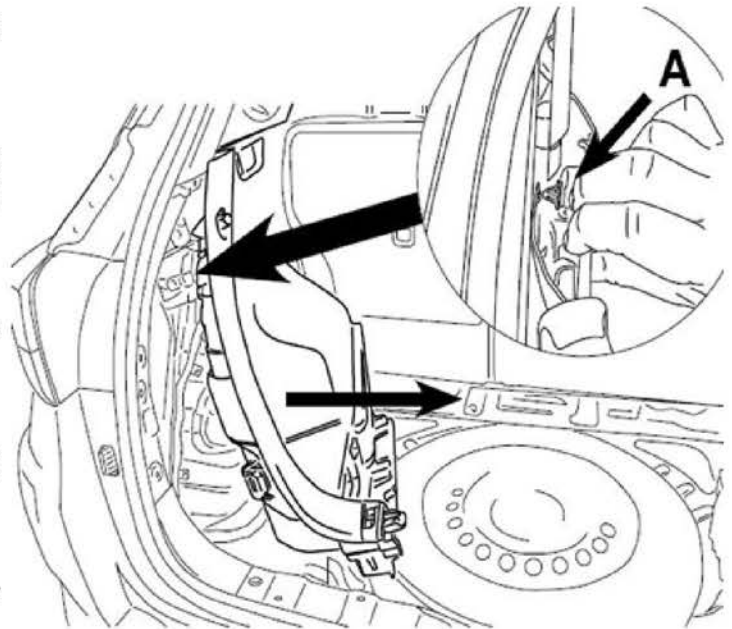

17. Behind the panel, cut the two (2) zip ties securing the tow hitch harness in place.

Pull the control module from the floor. It is held in place with an adhesive pad, and in some models with a factory harness, a 10mm nut. Remove the nut and store in a safe place for reinstallation.

**NOTE:** Make sure to remove all the pieces of the adhesive pad from the vehicle body.

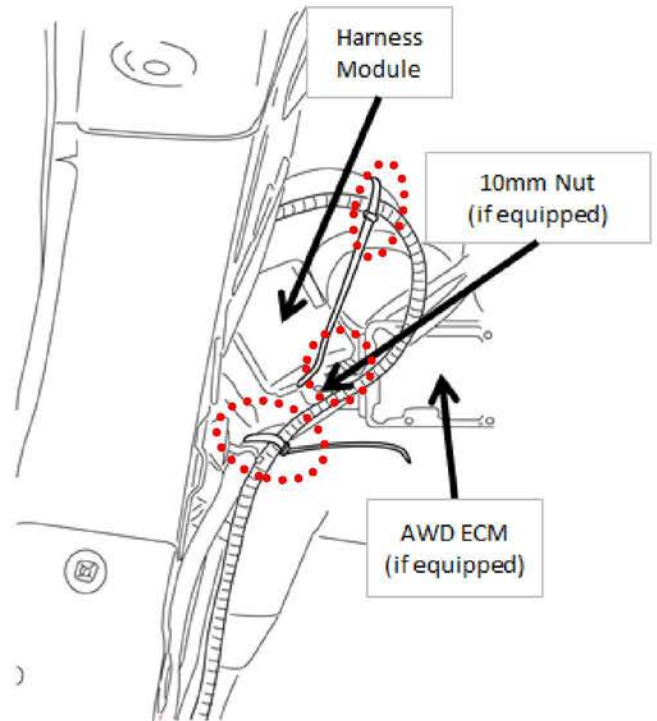

18. At the rear threshold area, pull the three (3) zip ties securing the tow hitch harness off the mounting studs, or cut the standard zip ties.

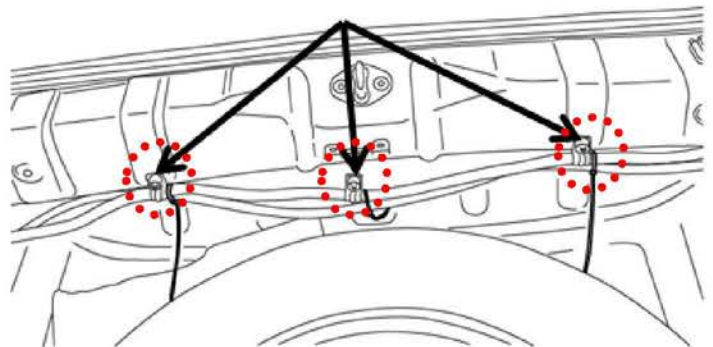

19. Remove the Jack Assembly.

Remove the 10mm nut securing the harness onto the stud. Discard the nut. Remove the harness wire from the stud.

If applicable, remove the foam pad securing the harness to the vehicle body.

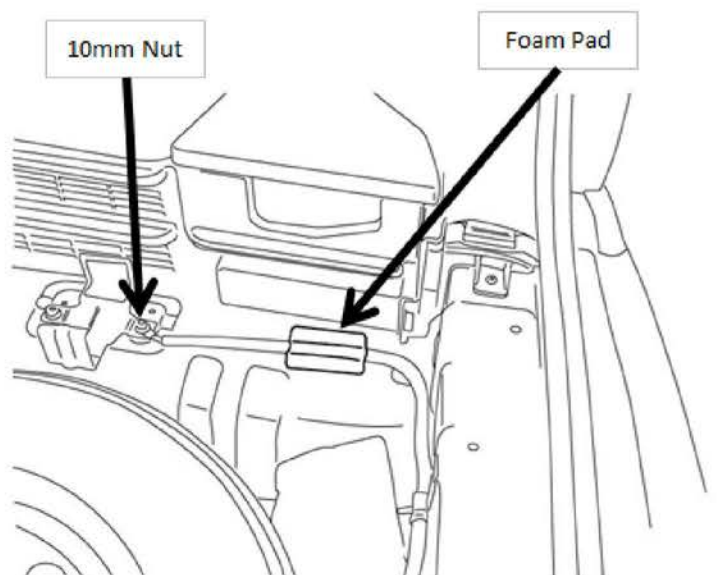

20. Remove the plastic cover on the driver side taillight.

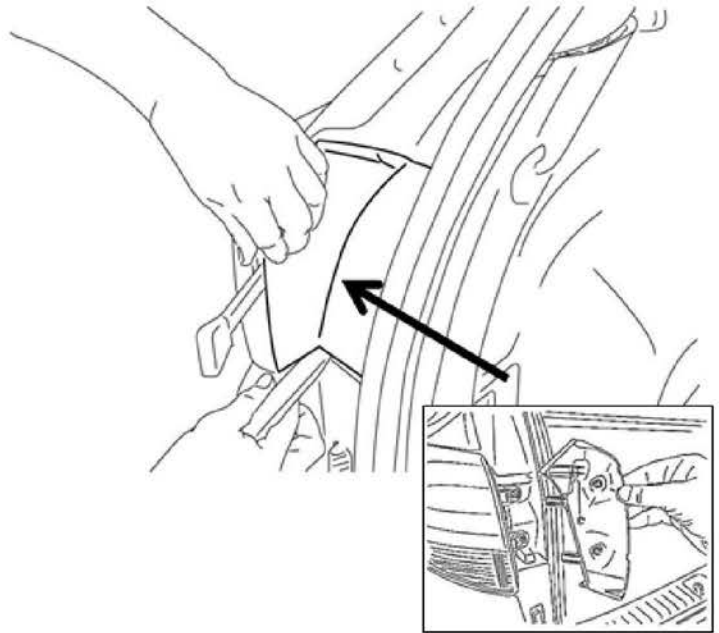

21. Remove the two (2) bolts holding the driver side taillight in place.

Dislodge the taillight.

**NOTE:** A Philips head screwdriver or a 10 mm socket can be used.

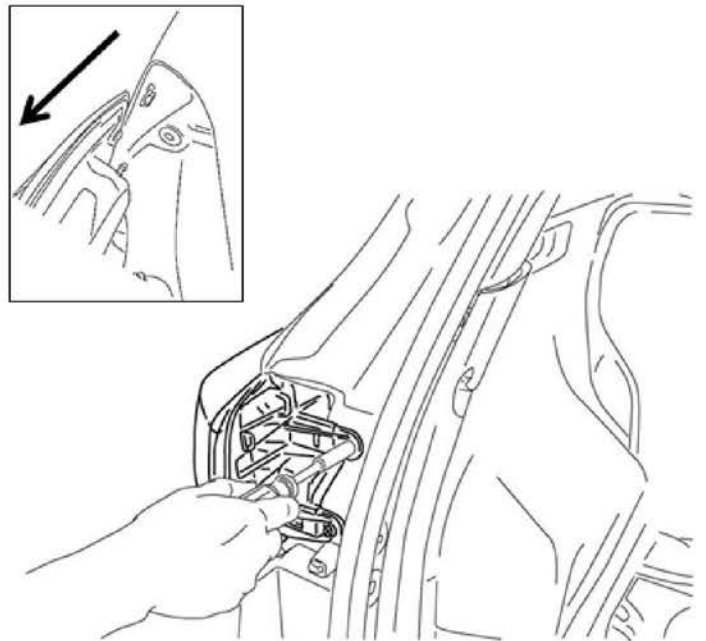



22. Disconnect the taillight connector and remove the taillight from vehicle.

**NOTE:** Some vehicles may have an Adapter Harness from Campaign 142 attached between the taillight and the vehicle harness. Remove and discard that Adapter Harness.

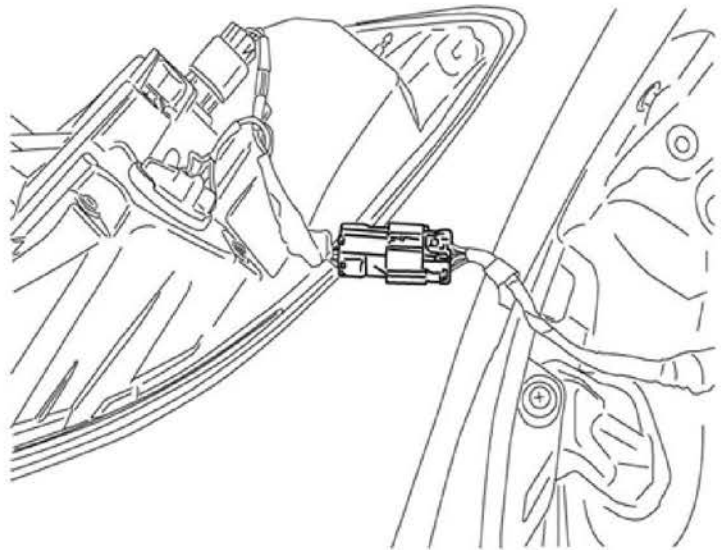

23. Remove the foam tape and disconnect the driver side tow harness signal wire from the vehicle harness.

Cut the zip tie securing the tow hitch harness to the bumper fascia mounting bracket.

Pull the tow hitch harness down to the ground, behind the bumper.

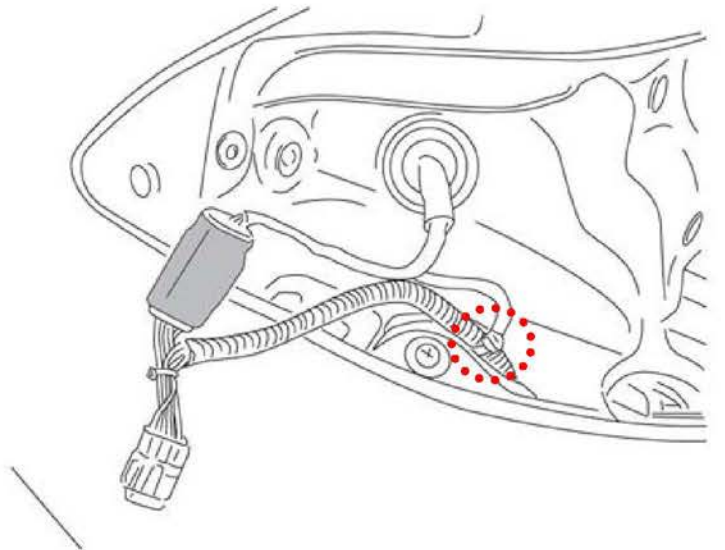

24. Remove the plastic cover on the passenger side taillight.

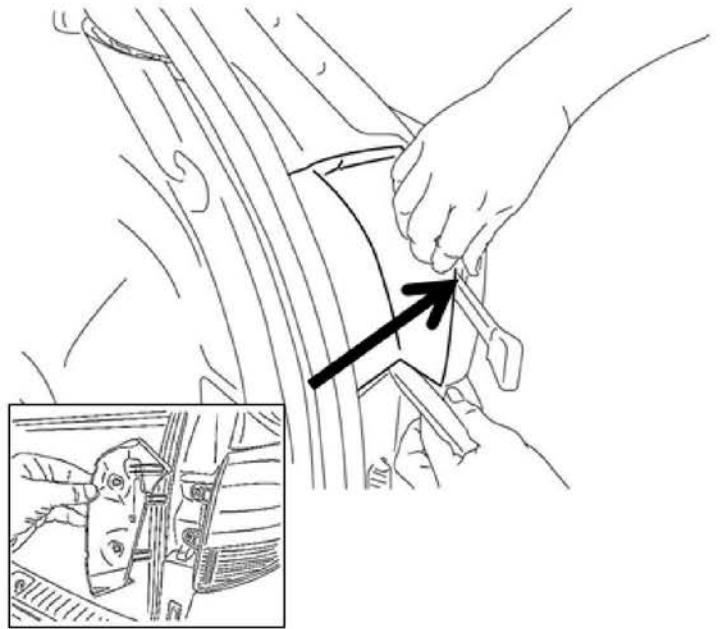

25. Remove the two (2) bolts holding the passenger side taillight in place.

Dislodge the taillight.

**NOTE:** A Philips head screwdriver or a 10 mm socket can be used.

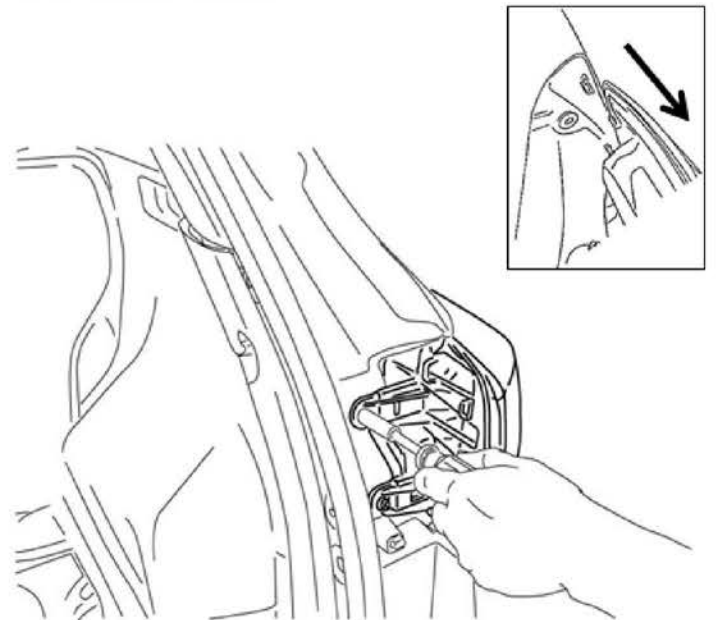

26. Disconnect the taillight connector and remove the taillight from vehicle.

**NOTE:** Some vehicles may have an Adapter Harness from Campaign 142 attached between the taillight and the vehicle harness. Remove and discard that Adapter Harness.

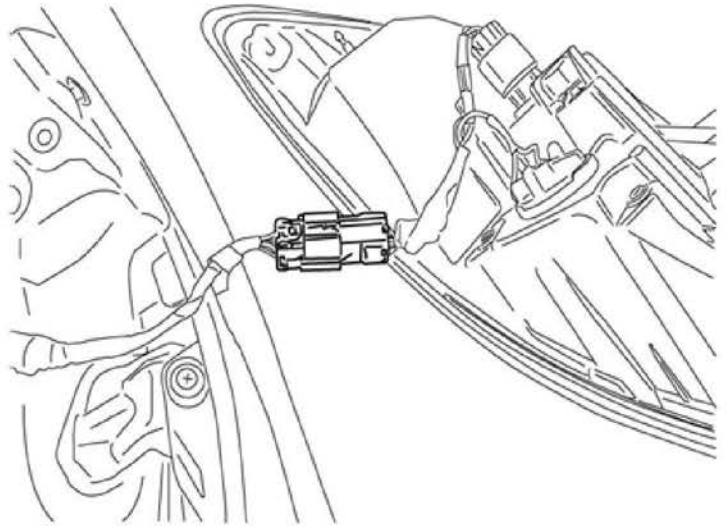

27. Remove the foam tape and disconnect the passenger side tow harness signal wire from the vehicle harness.

Cut the zip tie securing the tow hitch harness to the bumper fascia mounting bracket.

Reach underneath the vehicle and pull the passenger side harness branch and 4-Flat branch to the driver side aero cover area.

Pull the tow hitch harness down to the ground, behind the bumper.

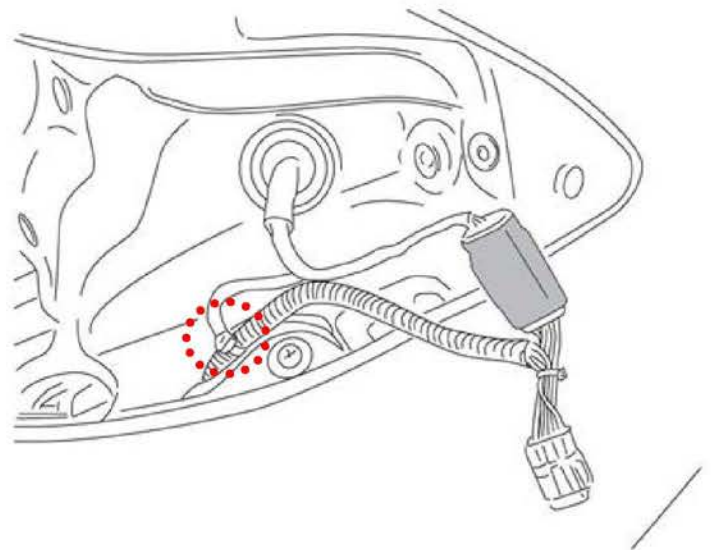

28. Pull the passenger side harness branch over to the area behind the driver side rear wheel.

Pull the complete harness through the grommet hole in the vehicle floor behind the driver side rear interior side lining panel.

29. Cut the 4-pin towing connector off the harness.



**REINSTALL HARNESS PROCEDURE (TUCSON[TL])**

30. Identify the four (4) harness branches on the tow hitch harness that lead away from the preinstalled rubber grommet. Route the four (4) harness branches behind the driver side interior trim panel, then through the hole opening as shown.

*Without Factory Harness:*

Seat the tow hitch harness grommet into the hole opening.

*With Factory Harness:*

Do not seat the tow hitch grommet harness. Grommet will be seated in step 51.

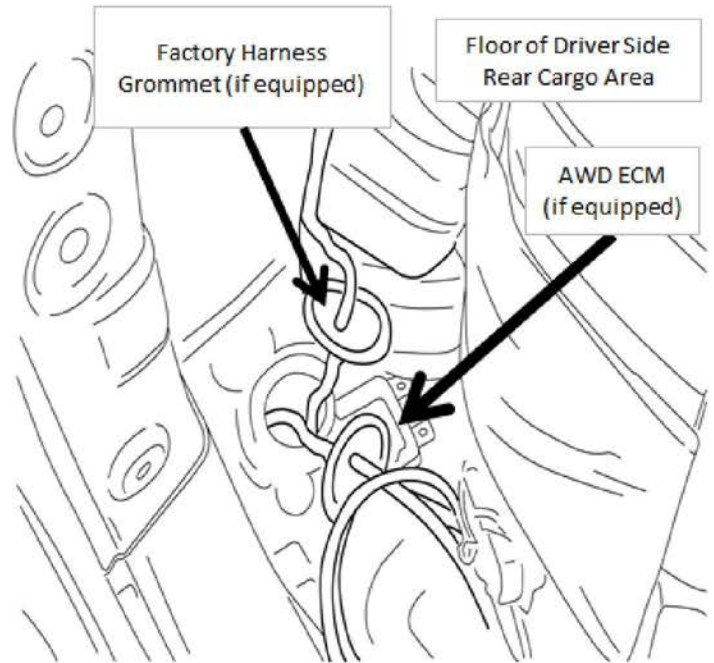

31. Using 50/50 isopropyl alcohol (70%) & water and a clean cloth, clean the surface as shown and allow to thoroughly dry.

*With Factory Harness:*

If not previously removed, remove the 10mm nut securing the AWD ECM (if equipped) to the mounting stud. Store in a safe location for reinstallation.

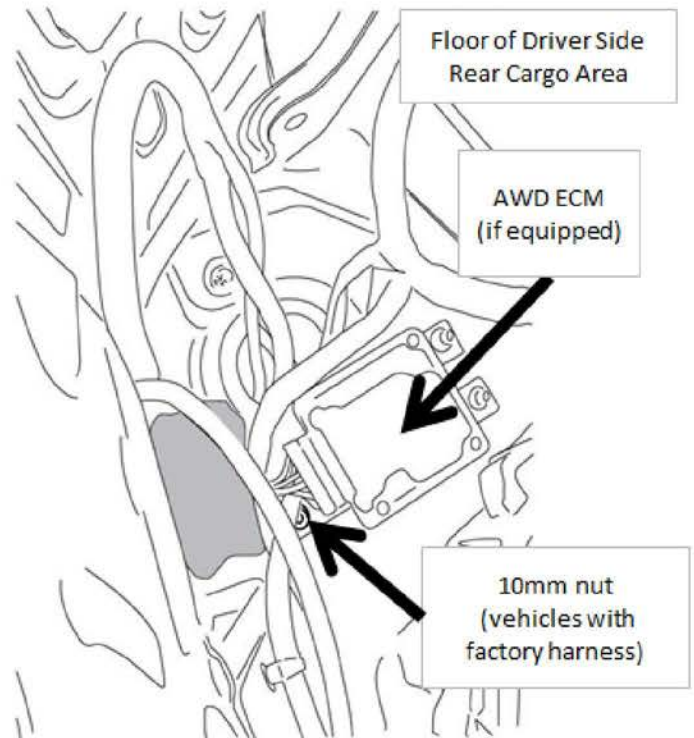

**32a. Without Factory Harness:**

Remove the foam tape adhesive liner from the tow hitch harness module. Position the module over the factory stud and secure the module firmly to the mounting surface as shown.

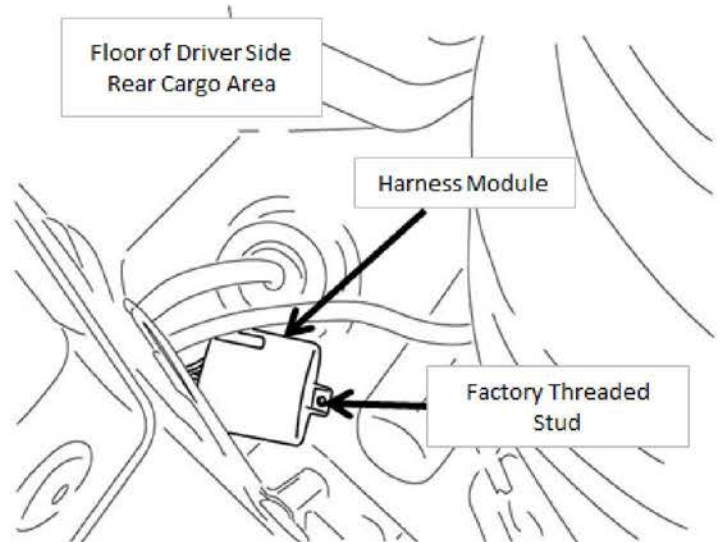

**32b. With Factory Harness:**

Make one (1) cut from the outside of the tow hitch harness rubber grommet to the center hole of the grommet as shown.

Remove the foam tape adhesive liner from the tow hitch harness module. Position the module over the factory stud and secure the module firmly to the mounting surface as shown. Reinstall the 10mm nut to the factory stud.

Position the tow hitch harness rubber grommet loosely above the hole opening. Position the factory harness into the cut that was made in the hitch harness rubber grommet. Make sure the factory harness grommet is above the tow hitch harness grommet. Using one 8" cable tie, loosely secure the two harnesses just above the tow hitch harness grommet (between the two rubber grommets). Do not tighten yet. Do NOT seat the tow hitch harness rubber grommet. It will be sealed in step 51.

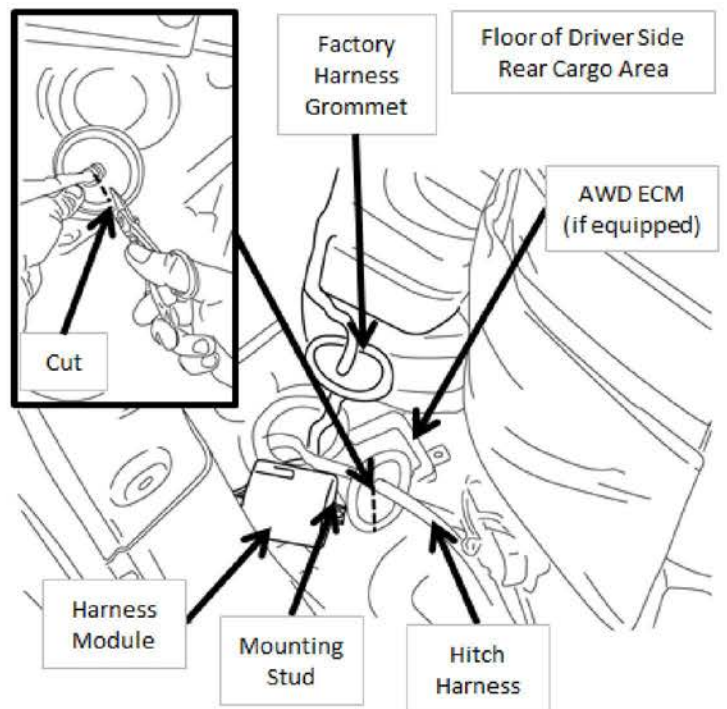



Secure the factory harness to the tow hitch harness with one cable tie as shown.

**NOTE:** The word "HITCH" is not printed on the grommet as shown. It is displayed for illustrative purposes only to identify the position of the tow hitch harness.





33. Identify the tow hitch harness ground/ring terminal, then route the ground wire out from behind the driver side interior trim panel into the cargo area.

*Without Factory Harness:*

Route the tow harness as shown, then loosely secure with one (1) 8" push mount cable tie and one (1) 8" cable tie as shown. Do not tighten the cable ties until final routing is complete.

*With Factory Harness:*

Route the tow harness as shown, then loosely secure with two (2) 8" cable ties as shown. Do not tighten the cable ties until final routing is complete.

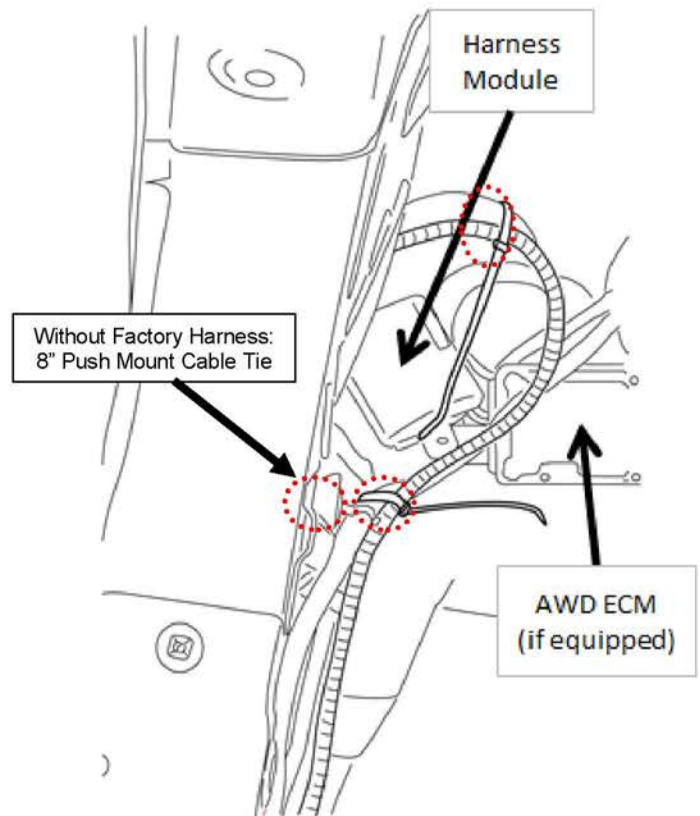

34. Route the tow hitch harness ground wire as shown.

*Without Factory Harness:*

Route the ground wire harness across the rear of the vehicle as shown. Loosely secure the ground wire harness to the mounting studs using three (3) 8" stud mount cable ties. Do not tighten the cable ties until final routing is complete.

*With Factory Harness:*

Loosely secure the ground wire harness to the factory harness near the mounting studs using three (3) 8" cable ties. Do not tighten the cable ties until final routing is complete.

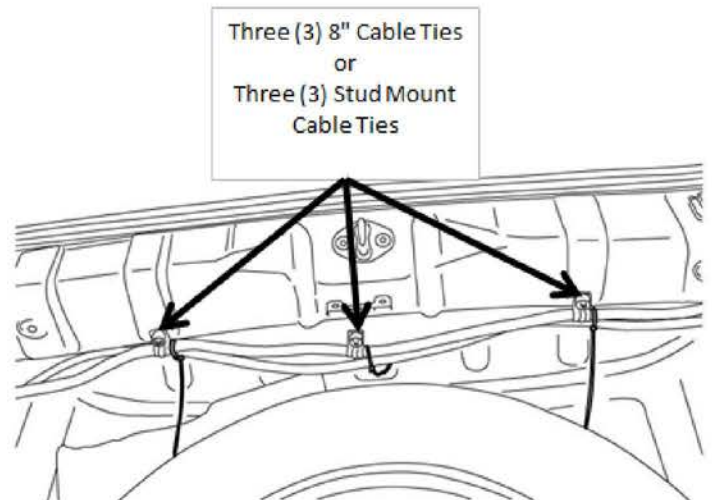

35. Install the ground wire ring terminal over the jack mounting bracket stud. Install one (1) provided M6 flange nut to the jack mounting bracket stud and torque to:  
3.93 N.m (0.40 Kgf.m, 34.8 lb-in)

**NOTE:** Be sure to use the supplied nut.

*With Factory Harness:*

Install one (1) 8" cable tie as shown.

*All Vehicles:*

Adjust the harness to remove any excess slack, then fully tighten all cable ties. Trim excess cable tie material.

Clean the cargo area surface with 50/50 isopropyl alcohol (70%) & water with a clean cloth and allow to thoroughly dry.

Secure the ground wire with one (1) foam pad as shown.

36. Reinstall the vehicle jack making sure it is properly secure and not loose.

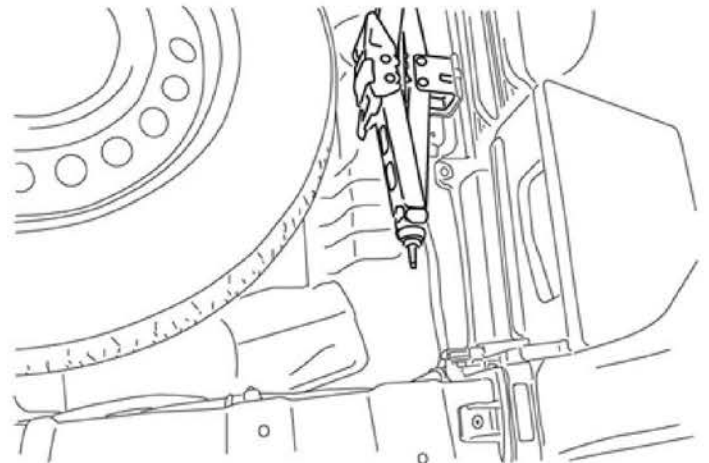
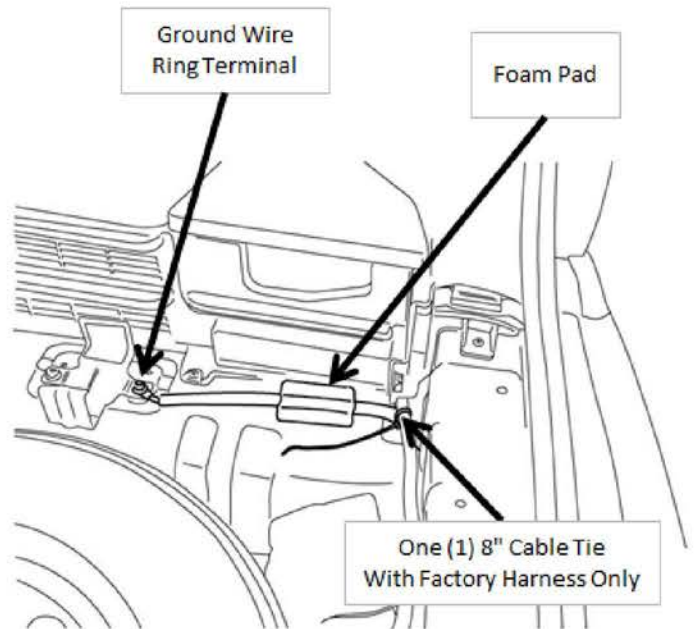

37. Reinstall the driver side interior trim panel. Make sure the clip removed in step 16 is engaged with the vehicle.

Reinstall the two (2) Phillips screws and rubber weatherstrip seal.

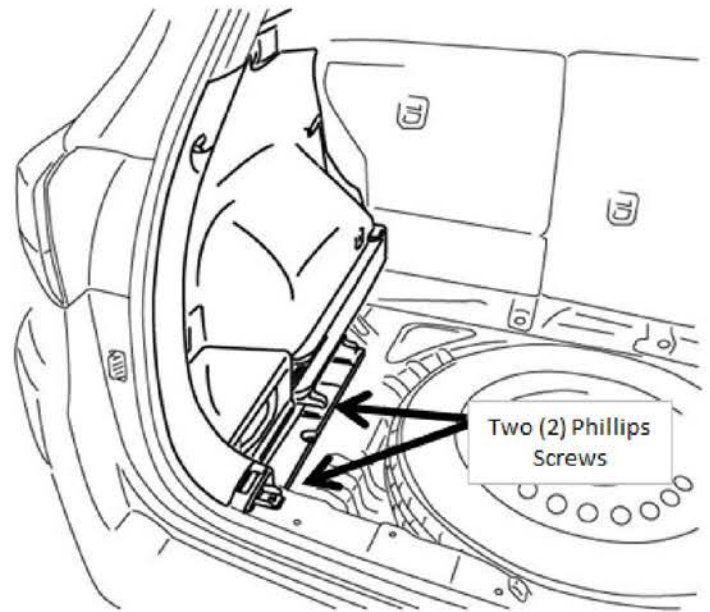

38. Pull weatherstrip seal back, then press downward to reinstall the plastic threshold panel. Reinstall the weatherstrip seal and two (2) plastic clips (A).

Make sure the weatherstrip seal is not trapped behind the interior trim panel or plastic threshold panel.

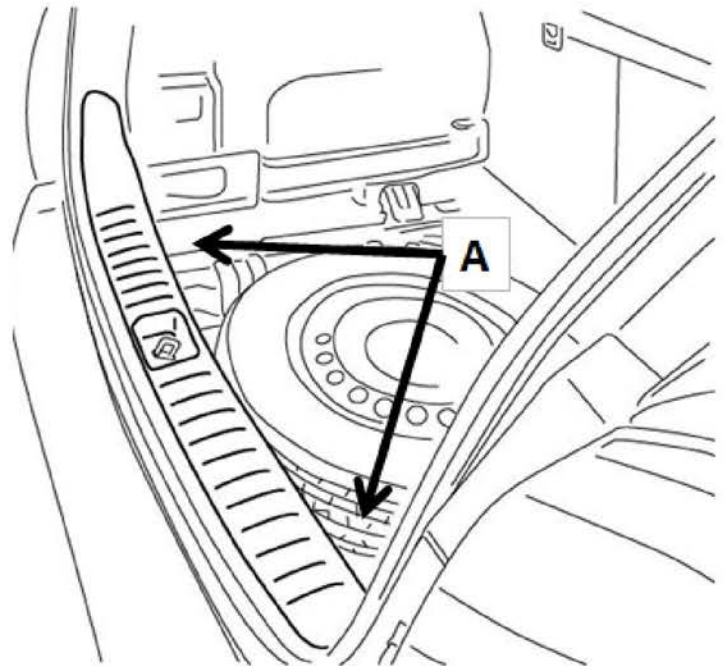



39. Raise the vehicle.



40. *Without Factory Harness:*  
Skip to the next Step

*With Factory Harness:*

From under the vehicle, seat the tow hitch rubber grommet into the hole opening.

Using one (1) 8" cable tie, secure the tow hitch harness to the factory harness as shown.

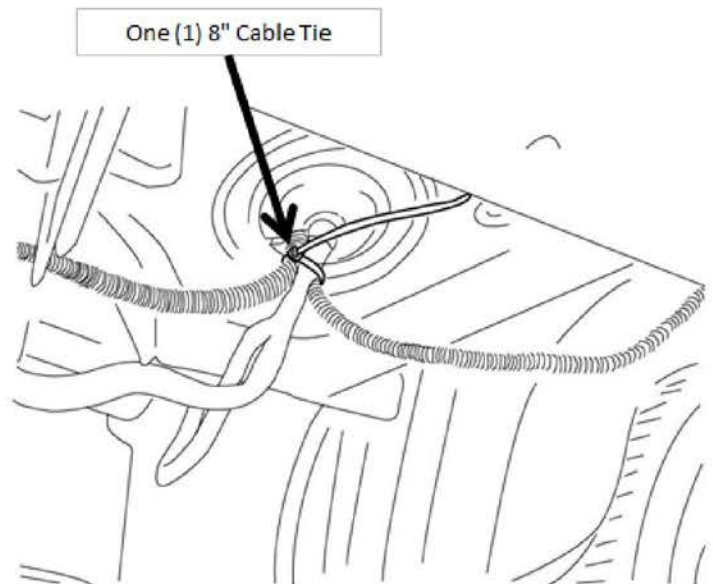

41. Route the tow hitch harness grey connector over the rear subframe, inside the frame and towards the front of the vehicle.

**CAUTION!** When routing Wires, avoid any moving areas that may cut or pinch the Wires.

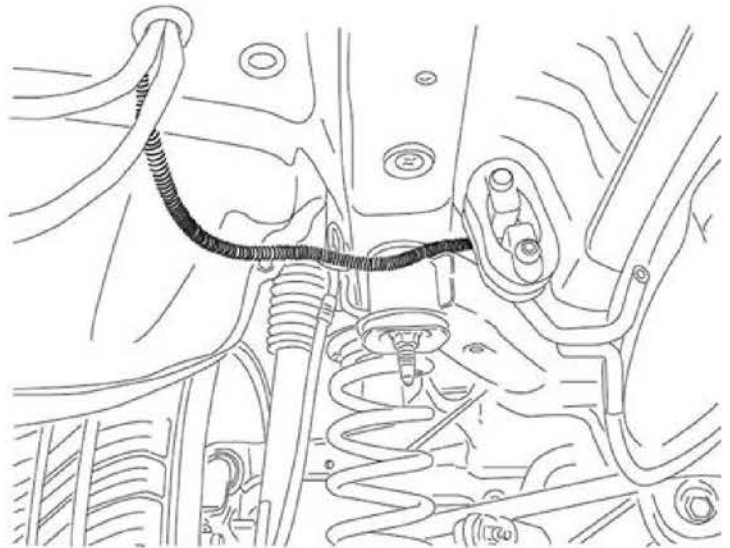

42. Using one (1) 8" push mount cable tie, secure the power wire harness to the vehicle subframe hole as shown.

Route one (1) 8" cable tie routed through the frame, then secure the power wire harness as shown.

**NOTE:** Do not tighten the cable ties until final routing is complete.

**CAUTION!** When routing Wires, avoid any moving areas that may cut or pinch the Wires.

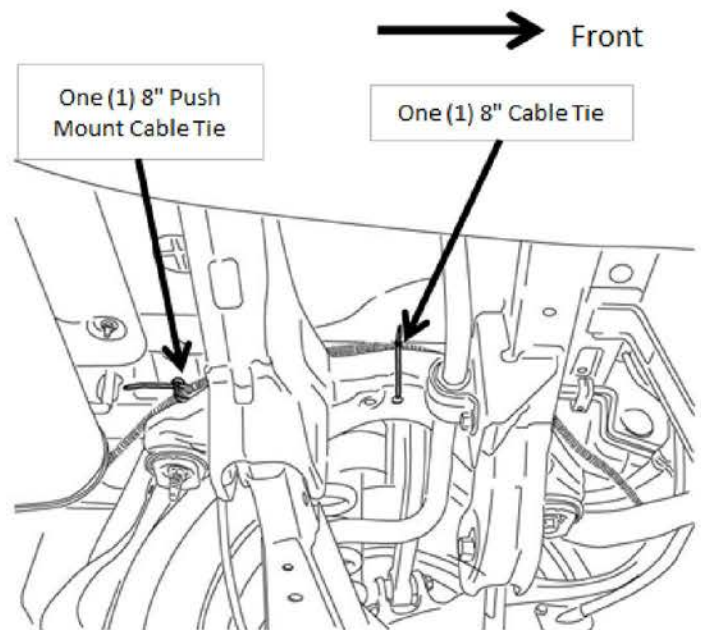

43. Secure the power wire harness to the vehicle fuel tank harness using three (3) 8" cable ties as shown.

**WARNING!** Do NOT secure the Power Wire Harness directly to the Vehicle Brake Lines or Fuel Lines. Only secure to the Brake Line Brackets.

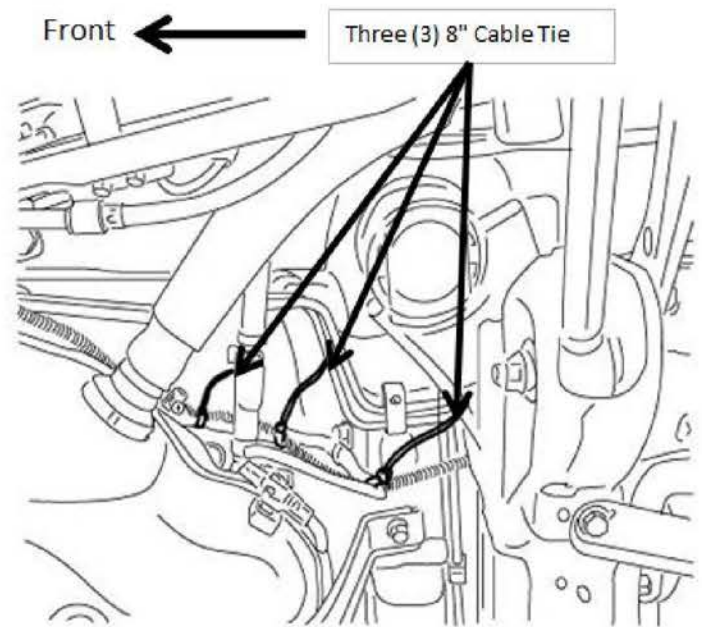

44. Route the power wire harness alongside the fuel tank, then secure the harness to the two (2) brake line brackets using two (2) 8" cable ties as shown (A).

Continue routing the power wire harness forward, then secure the harness to the parking brake cable bracket using one (1) 8" cable tie as shown (B).

**WARNING!** Do NOT secure the Power Wire Harness directly to the Vehicle Brake Lines or Parking Brake Cable. Only secure to the Brake Line Brackets or Parking Cable Brackets.

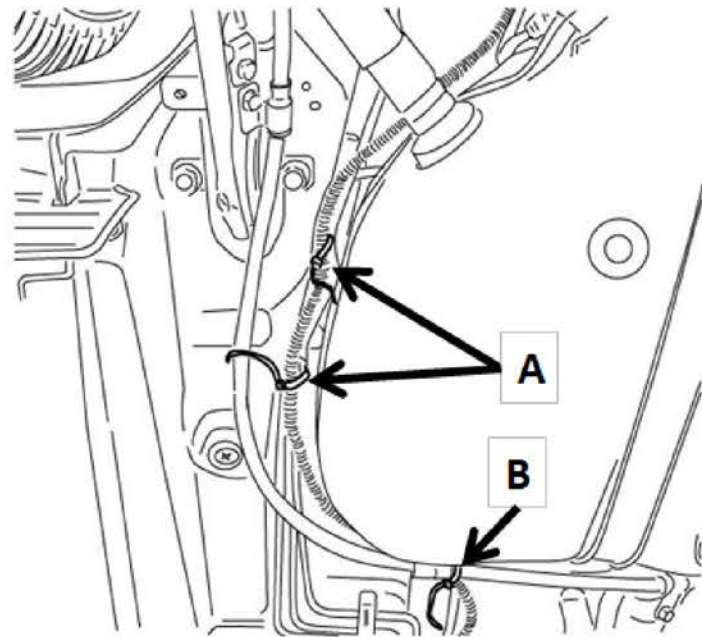



45. Connect the power wire harness connector to the tow hitch harness connector.

Position the connectors above the brake lines, then secure the harness to the brake Line bracket using one (1) 8" cable tie as shown.

Adjust the harnesses to eliminate any slack, then tighten all cable ties. Trim excess cable tie material.

**NOTE:** Leave slack at the rear aero undercover, as that area becomes tight when the harness is finally secured.

**WARNING!** Do NOT secure the Power Wire Harness directly to the Vehicle Brake Lines. Only secure to the Brake Line Brackets.

46. Reinstall the plastic undercover and five (5) 10mm bolts.

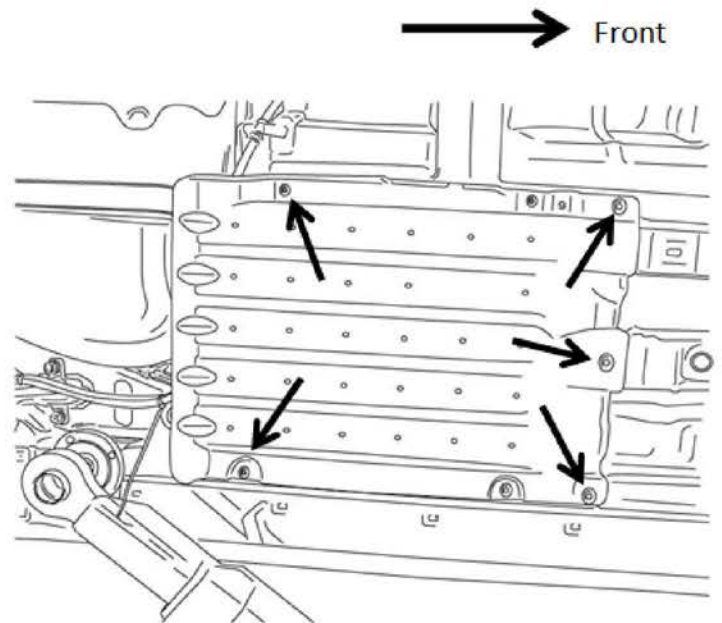
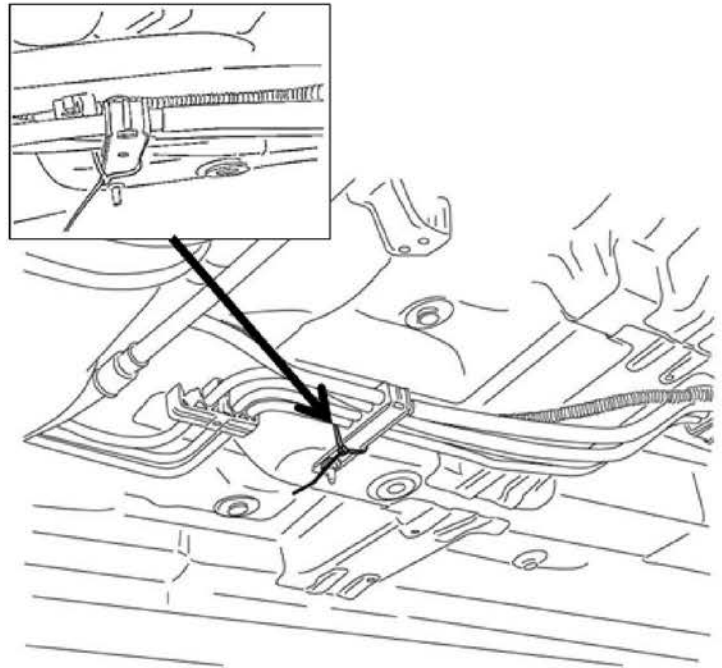

47. Route the passenger side signal harness and 4-Flat connector harness over the driver side bumper support.

*With Factory Harness:*

Using one (1) 8" cable tie, secure the passenger side signal harness to the factory harness as shown. Tighten the cable tie and trim excess wire tie material.

*Without Factory Harness:*

Secure the passenger side signal harness to the factory harness clip hole at the left rear corner of the bumper. Pull this zip tie secure now.

**NOTE:** Make sure to capture both branches of the tow hitch harness with the zip tie.

48. Route the 4-Flat connector harness to the center of the vehicle.

Route the right side signal harness to the passenger side of the vehicle.

Using three (3) 8" cable ties, secure the harnesses to the factory harnesses as shown.

**NOTE:** For vehicles without a factory harness, secure the tow harness to the three (3) harness clip holes at the bumper.

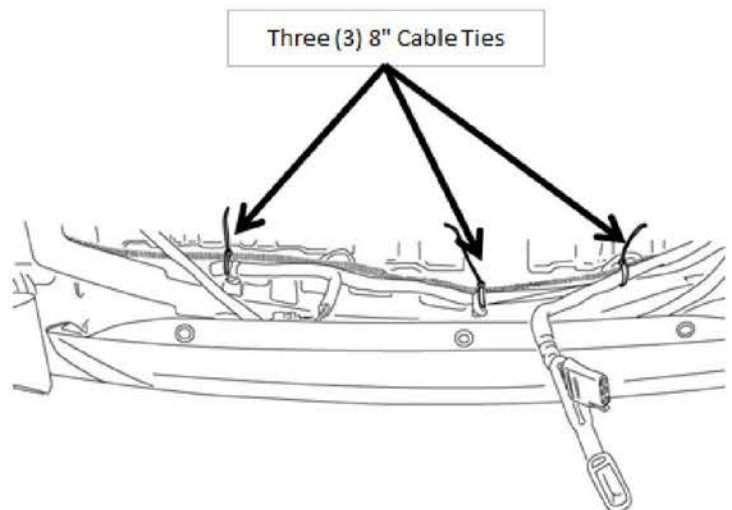
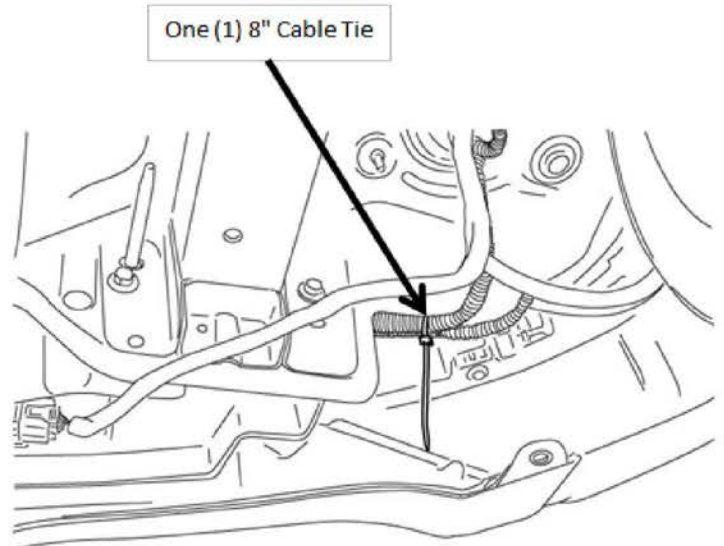

49. Install the tow hitch harness 4-Flat connector into the tow hitch connector mounting bracket. Make sure the ground pin is positioned towards the driver side of the vehicle.

Make sure the 4-Flat connector is fully seated with the rubber detent visible and install the connector cover.

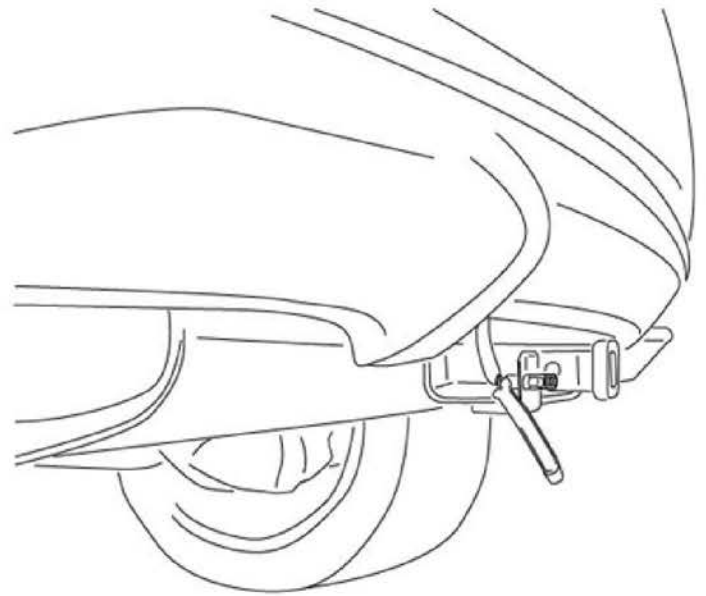

50. Secure the passenger side signal harness using one (1) 8" cable tie. Attach the cable tie to the factory hole in the rear bumper as shown. If equipped with blind spot detection, secure to the factory harness.

Adjust the harnesses to reduce excess slack, then tighten all cable ties. Trim excess cable tie material.

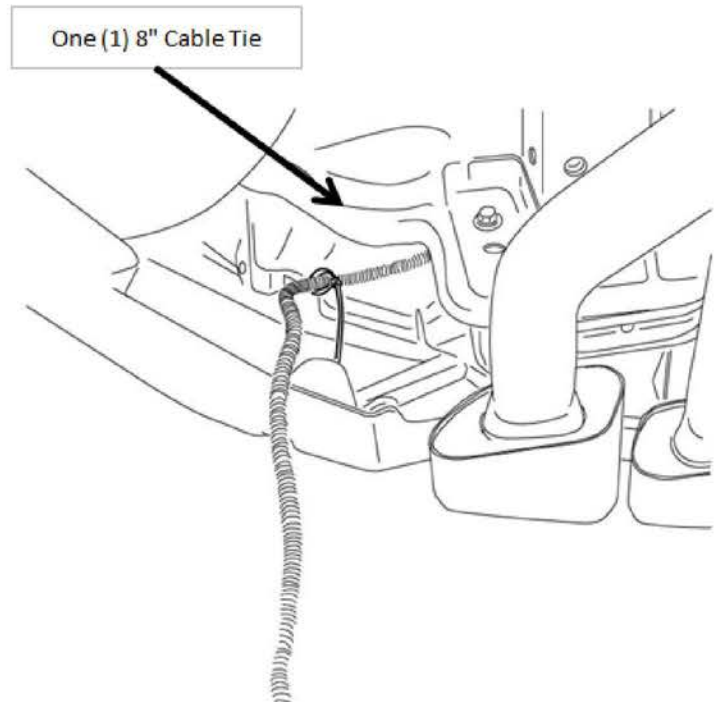



51. *With Factory Harness:*

Apply RTV silicone to the tow hitch harness rubber grommet. Apply silicone to the base of the grommet, the surface area surrounding the harnesses, and the slit that was created in step 32b. Ensure that all openings are completely sealed with RTV.

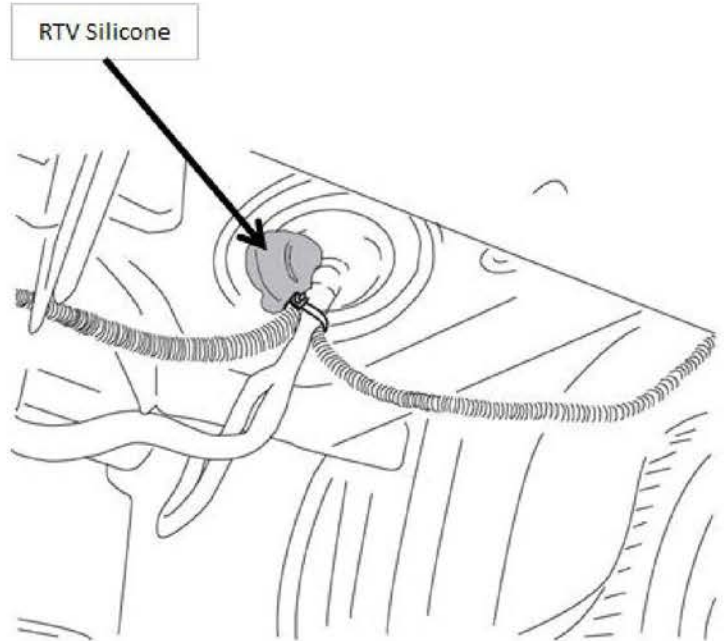

52. Note the location the tow harness will be routed to the driver side taillight assembly.

If equipped, note the location of the blind spot detection sensors. Avoid routing the tow harness near any of the sensors.

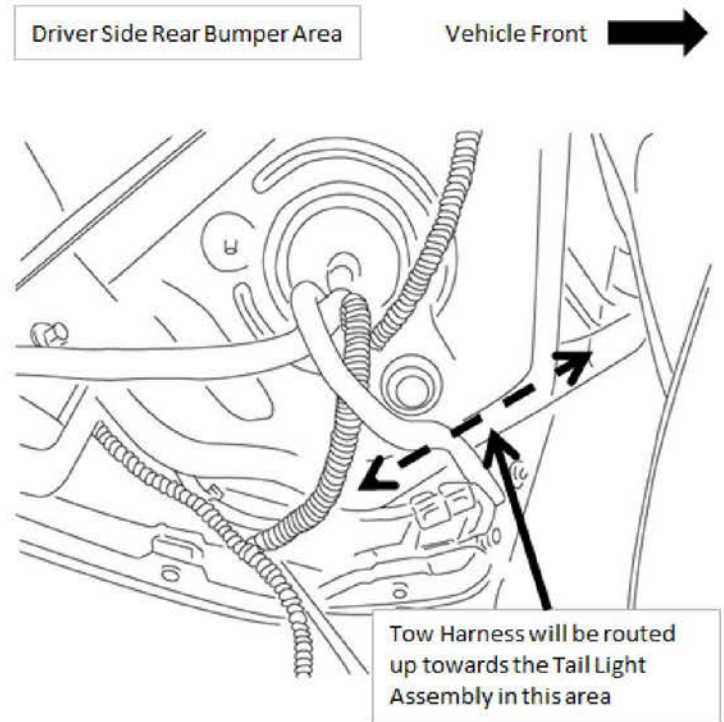

- 53. Note the location the tow harness will be routed to the driver side taillight assembly.

If equipped, note the location of the blind spot detection sensors. Avoid routing the tow harness near any of the sensors.

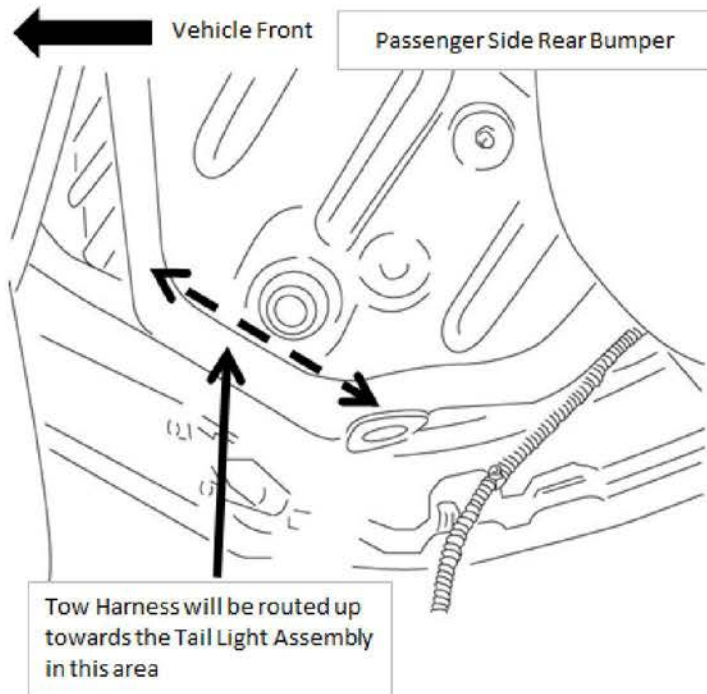

- 54. Lower the vehicle.

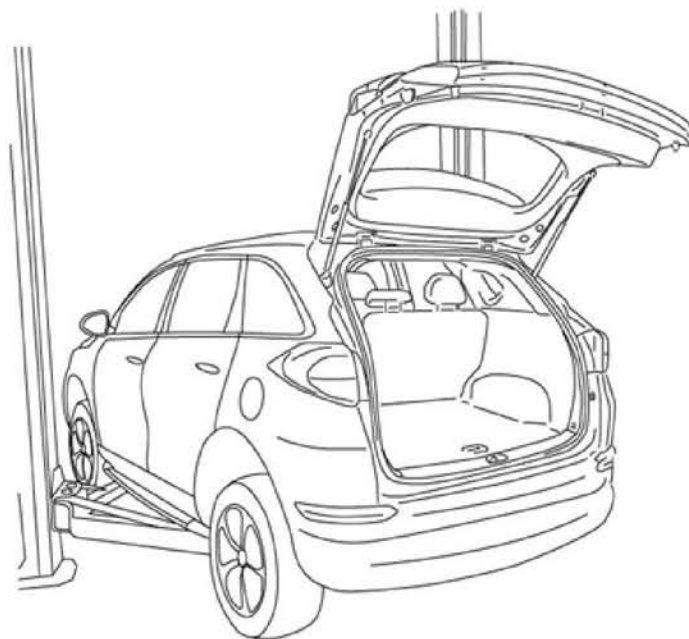

55. Using a fish wire, route the passenger side signal harness through the tail light opening as shown.

If applicable, make sure not to route the tow harness near any blind spot detection sensors. Be sure to route the tow harness as illustrated in step 57.

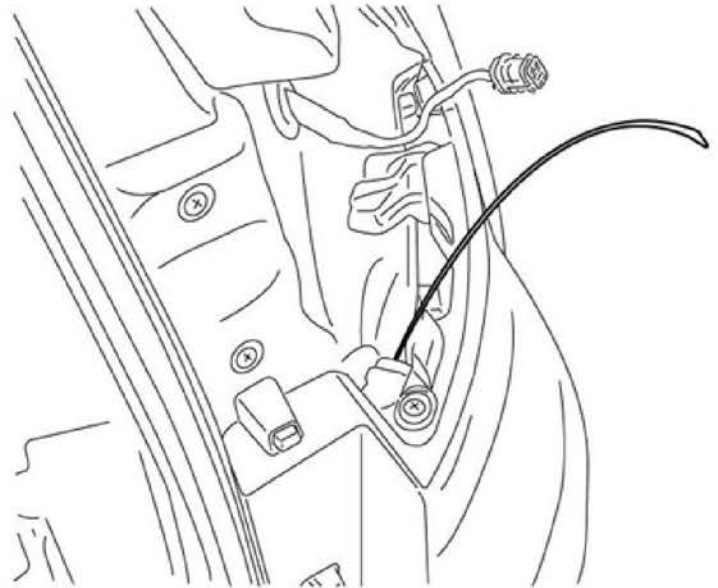

56. Pull the passenger side signal wire harness up through the tail lamp opening making sure to remove any excess slack in the harness.

Using one (1) 8" cable tie, secure the signal wire harness to the bumper fascia mounting bracket. Trim excess cable tie material.

If applicable, make sure not to route the tow harness near any blind spot detection sensors. Be sure to route the tow harness as illustrated in step 57.

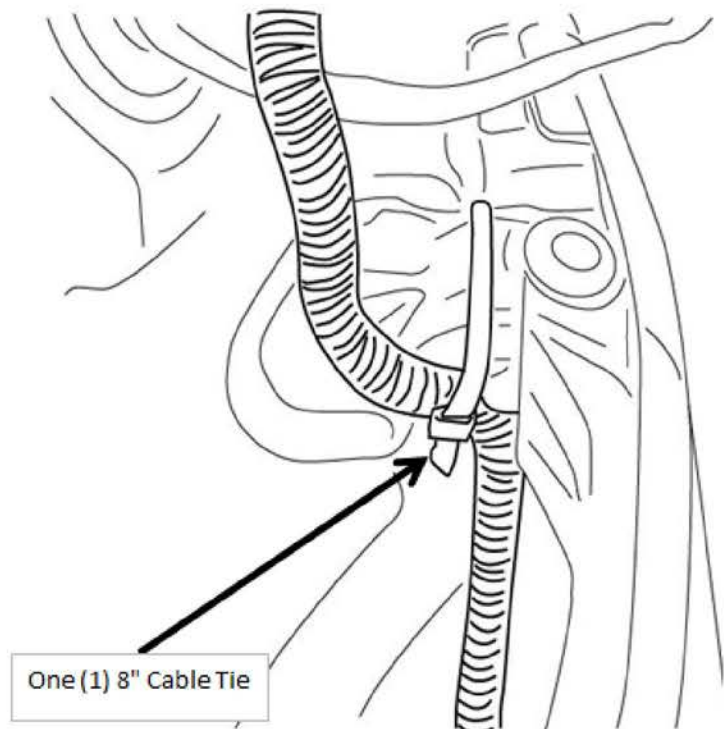



57.

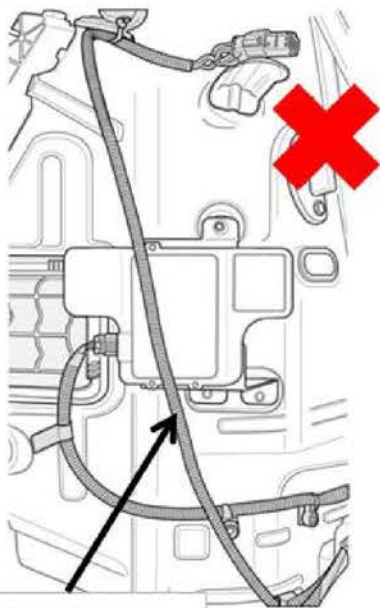

Incorrect Tow Harness Position over Top of BSD

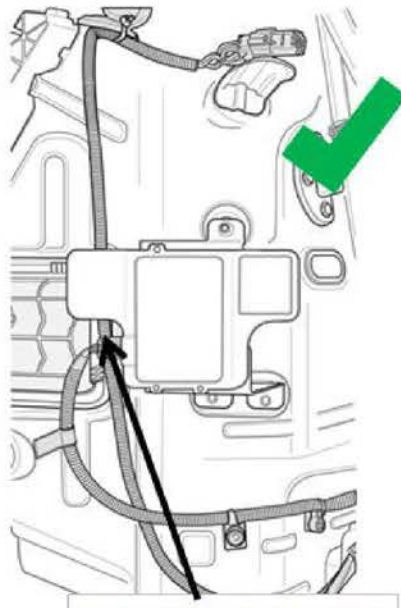

Correct Tow Harness Position to Left of BSD Bracket

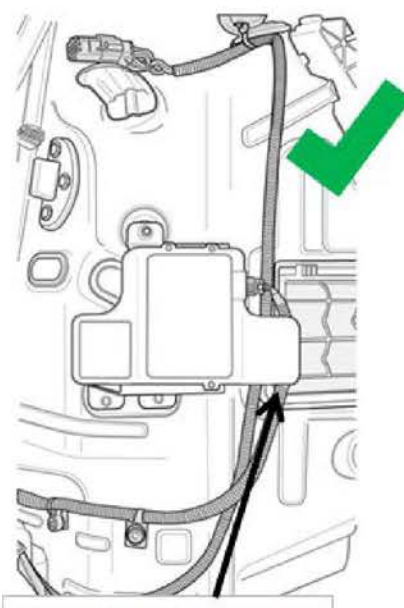

Correct Tow Harness Position to Right of BSD Bracket

58. Connect the passenger side signal harness connector to the vehicle harness connector.

Wrap the connector with one (1) foam pad as shown.

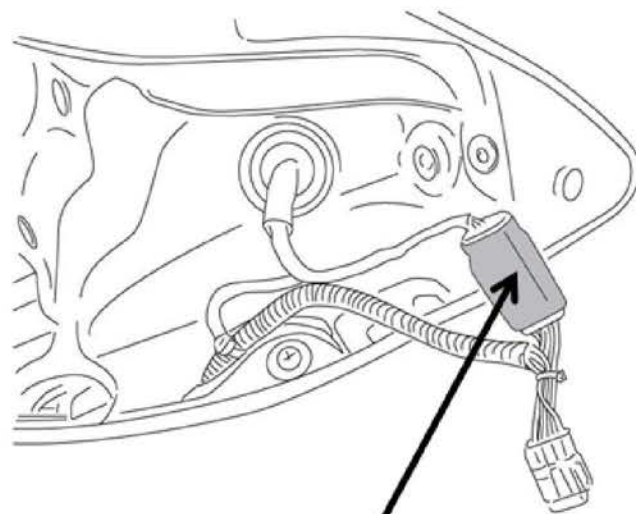

One (1) Foam Pad

59. Connect the passenger side tow harness signal wire to the passenger side tail light.

Tuck the connector with foam pad between the tail light connectors and the tail light housing as shown.

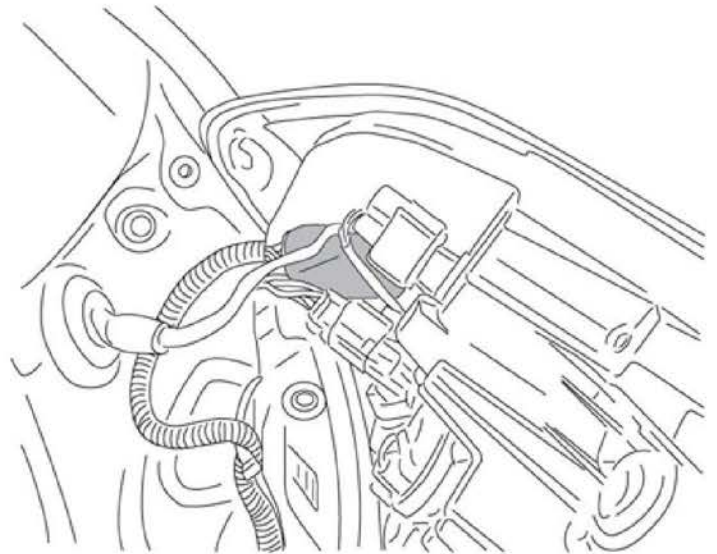

60. Reinstall the passenger side tail light and two (2) 10mm bolts.

Reinstall the passenger side black plastic cover.

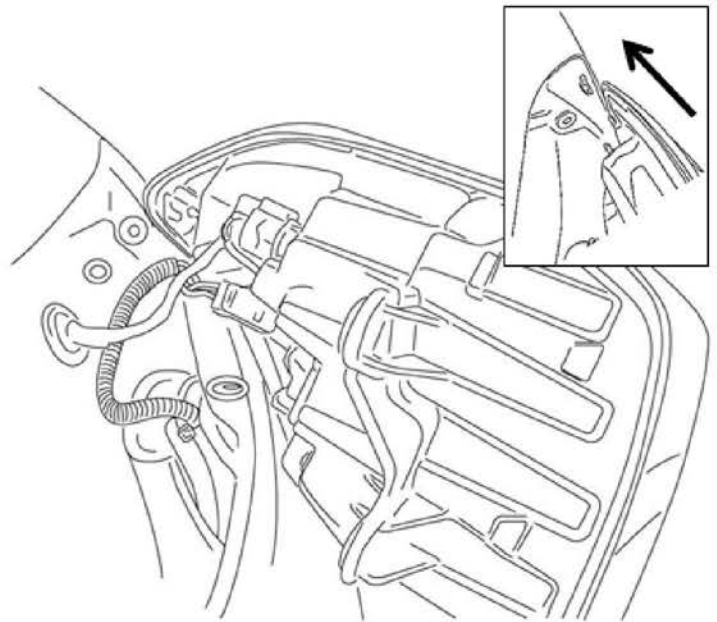

61. Using a fish wire, route the passenger side signal harness through the tail light opening as shown.

If applicable, make sure not to route the tow harness near any blind spot detection sensors. Be sure to route the tow harness as illustrated in step 57.

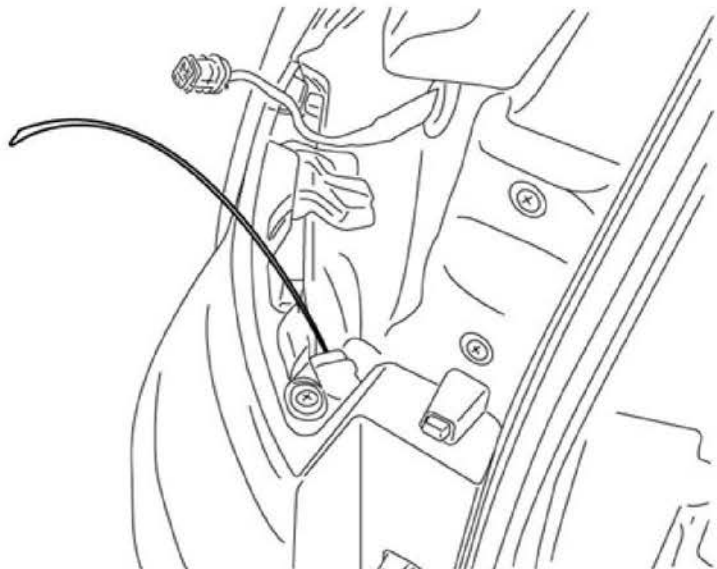

62. Pull the driver side signal wire harness up through the tail lamp opening making sure to remove any excess slack in the harness.

Using one (1) 8" cable tie, secure the signal wire harness to the bumper fascia mounting bracket. Trim excess cable tie material.

If applicable, make sure not to route the tow harness near any blind spot detection sensors. Be sure to route the tow harness as illustrated in step 57.

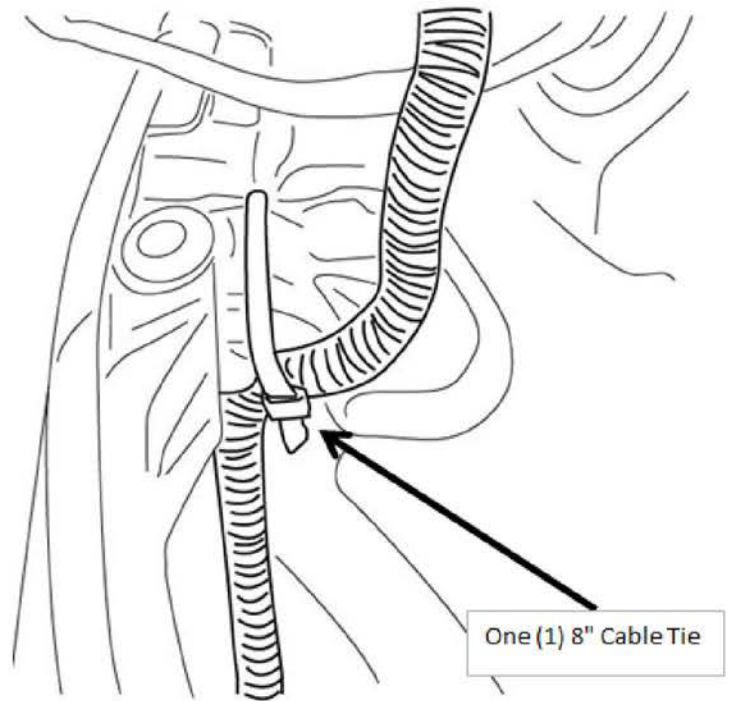

63. Connect the driver side signal harness connector to the vehicle harness connector.

Wrap the connector with one (1) foam pad as shown.

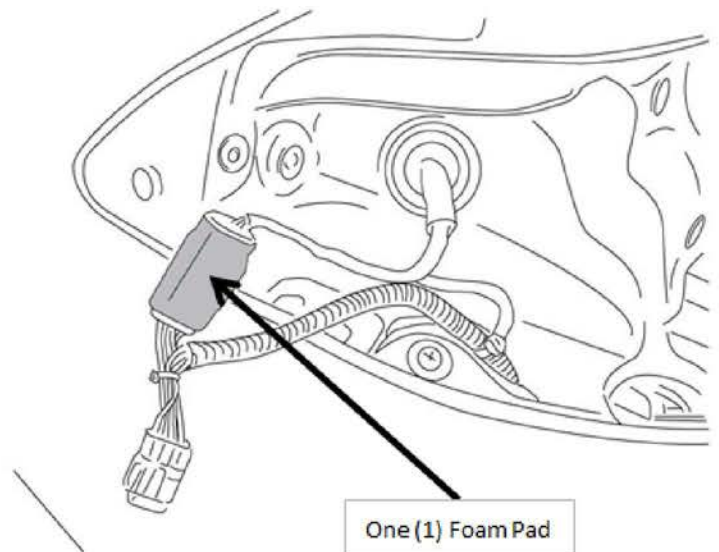



64. Connect the driver side tow harness signal wire to the driver side tail light.

Tuck the connector with foam pad between the tail light connectors and the tail light housing as shown.

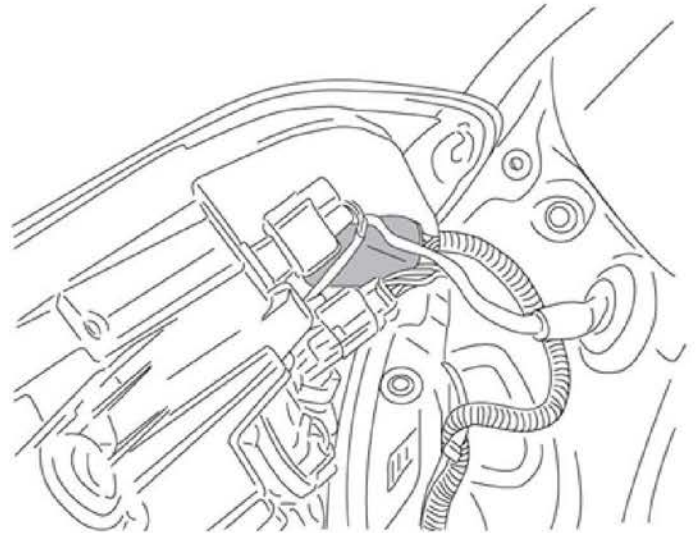

65. Reinstall the driver side tail light and two (2) 10mm bolts.

Reinstall the driver side black plastic cover.

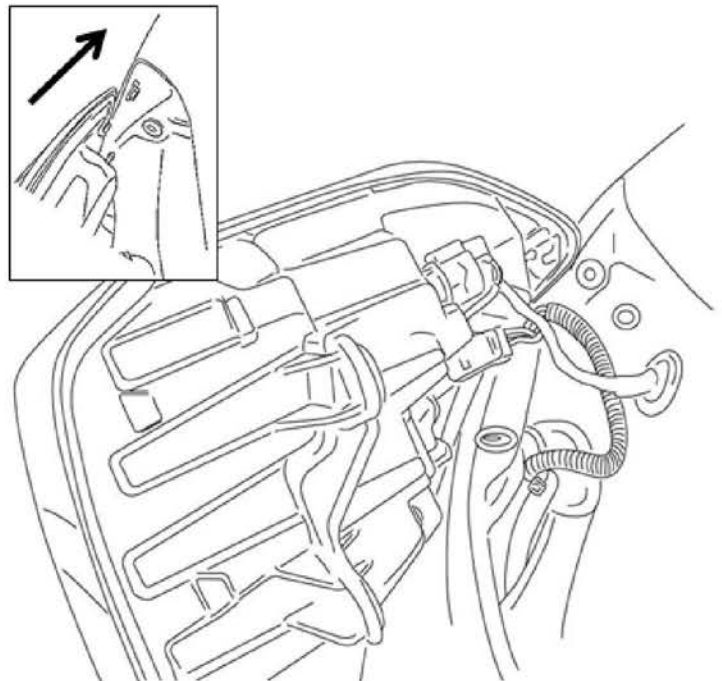

66. Reconnect the vehicle's negative (-) battery cable and torque to:  
3.93 N.m (0.40 Kgf.m, 34.8 lb-in)

Close the hood.

Reprogram any pre-set radio stations (if applicable).

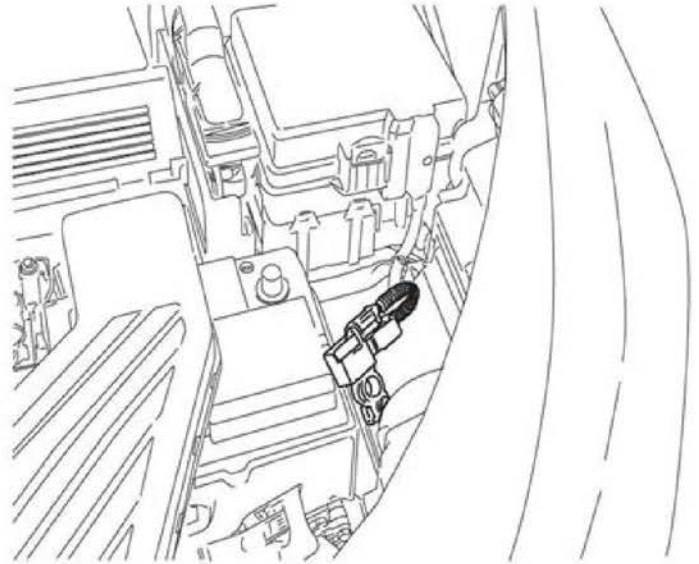

67. Perform the Function Check found on page 48.

**NOTE:** This may require a 2<sup>nd</sup> person to assist.

68. Reinstall cargo floor panel and retractable cargo cover, if equipped.

Close liftgate.

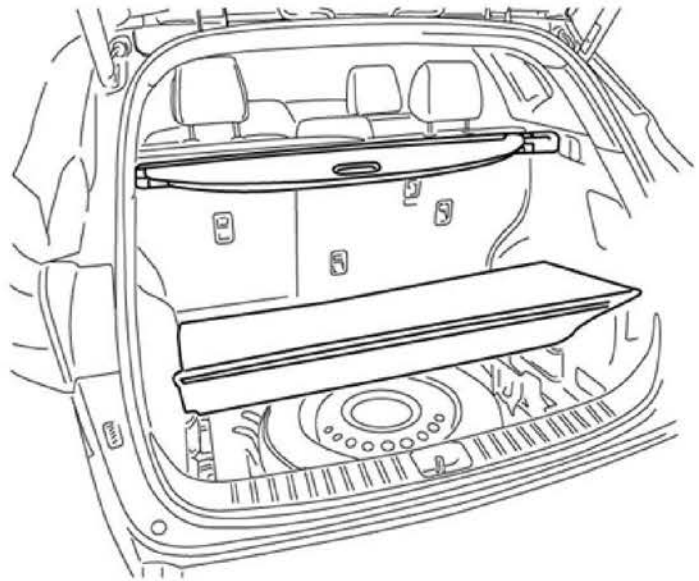

69. Reinstall the driver side plastic undercover and three (3) plastic clips.

If applicable, reinstall the driver side rear mudguard.

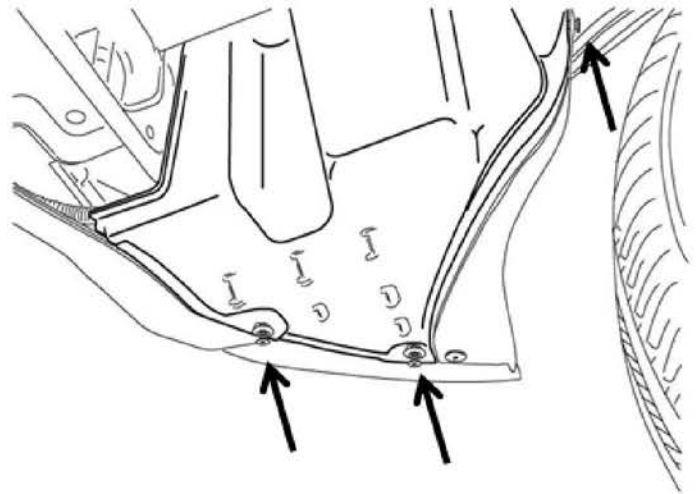

70. Reinstall the passenger side plastic undercover and three (3) plastic clips.

If applicable, reinstall the passenger side rear mudguard.

Use OP CODE TOWHITR0.

**FINISH**

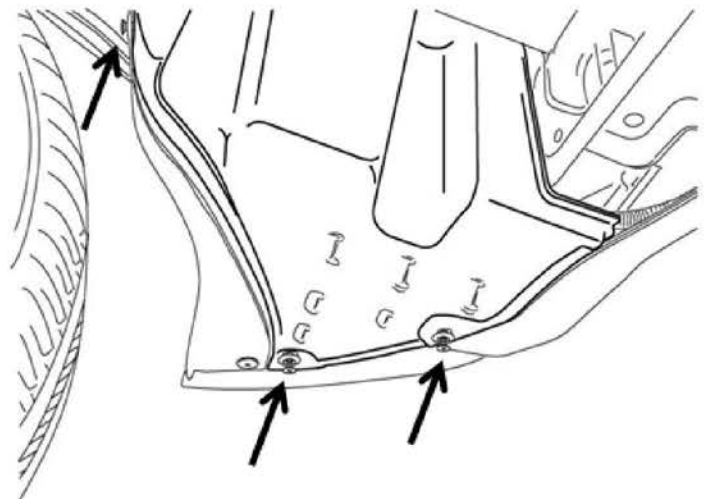



Function Check for NC and TL.

**FUNCTION CHECK**

1. Turn the ignition ON and confirm the vehicle rear brake lights, tail lights, and turn signals operate correctly.



2. Using a test light or voltmeter, test the 4-Way Flat Connector at the tow hitch for tail light, brake light, right turn signal, left turn signal, and hazard indicator circuits.



Function	Proper Operation
Tail Light	Tail/Side Markers ON
LH Turn	LH Turn/Stop FLASHING
RH Turn	RH Turn/Stop FLASHING
Brake Lights	Both Turn/Stop ON
Hazard Lights	Both Turn/Stop FLASHING
Brake & LH Turn	LH Turn/Stop FLASHING, RH Turn/Stop ON
Brake & RH Turn	RH Turn/Stop FLASHING, LH Turn/Stop ON

