



Service Bulletin

INFORMATION

Subject: Front Seat Lateral Movement, Clunk, Squeak, Click Noise or Shift While Cornering

Models: 2012-2016 Buick Regal
2012-2016 Buick Verano
2011-2015 Chevrolet Cruze
2016 Chevrolet Cruze (VIN P)
2013-2015 Chevrolet Malibu
2016 Chevrolet Malibu Limited (VIN 1)
2014-2016 Chevrolet Impala (VIN 1)
2014-2016 Chevrolet SS

Attention: This PI also applies to any of the above models that may be Export from North America vehicles.

This PI has been revised to add the 2016 Model Year. Please discard PI0686E.

Condition/Concern

Some customers may comment on a lateral movement in the seat while cornering. This condition has also been described as a clunk, squeak, click noise or shift in the seat. This condition occurs on the driver side 6-way manual or power adjusted seat. This condition may also be present on the passenger side seat if the vehicle is equipped with a 6-way adjustable passenger seat.

This condition may be caused by movement between the seat pan and the seat cross tube.

Recommendation/Instructions



A clip has been made available to eliminate the lateral seat movement. Use the following steps to install the clip to the driver side seat. If the vehicle is equipped with a 6-way adjustable passenger seat, repeat the procedure on the passenger seat.

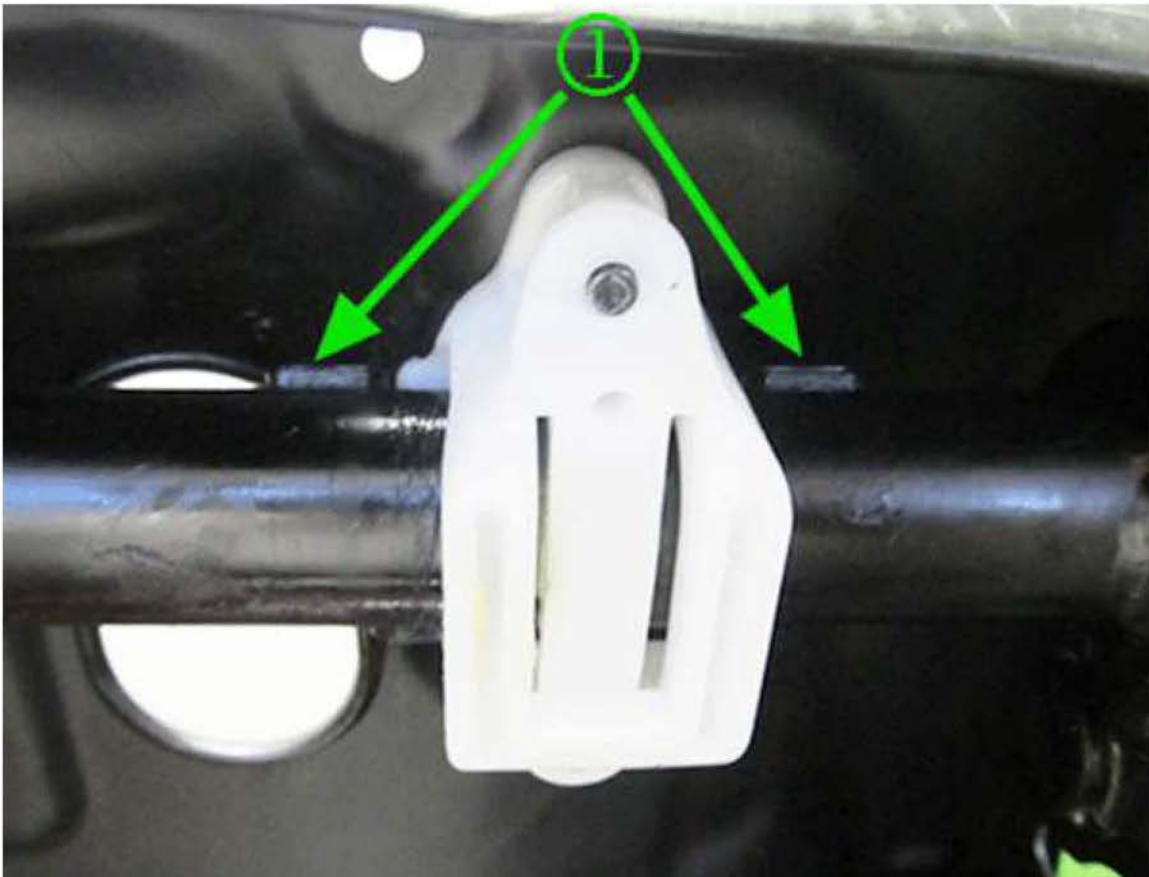

Important: On some vehicle models, a production change added welded brackets (1) to the seat crossbar on each side of the guide block to help retain its position. On these particular vehicles, it will be necessary to rework the new clip service part to ensure proper installation to the crossbar.

1. Raise the front of the seat bottom to the highest position and move the seat assembly to the rearmost position.

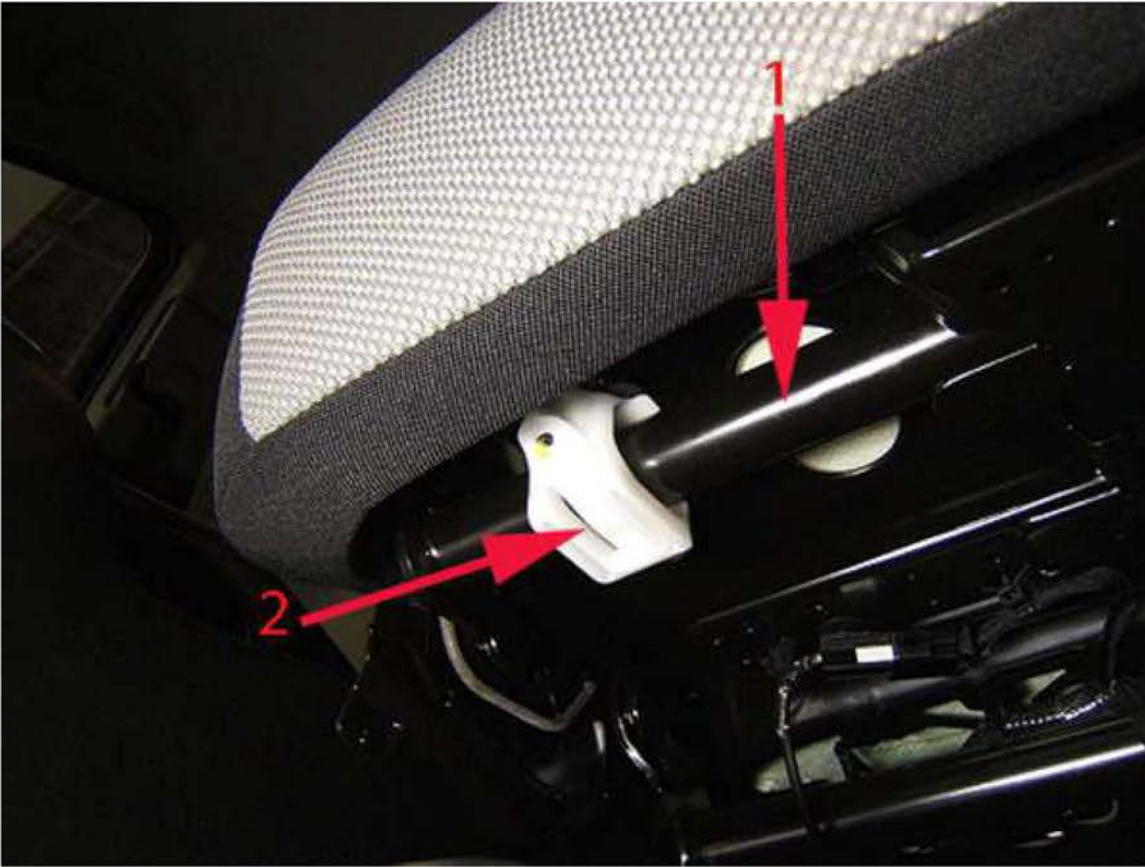

Note: Cruze shown, all others similar.

2. Locate the front crossbar as shown (1).
 - Identify the inboard guide block (2) on manually adjusted seats (closest to center console).
 - Identify the outboard guide block (2) on power adjusted seats (closest to door).
 - Inspect the seat crossbar for the existence of the welded brackets noted in the **Important** above.
 - If no brackets are found on the crossbar, continue ahead to step #3.

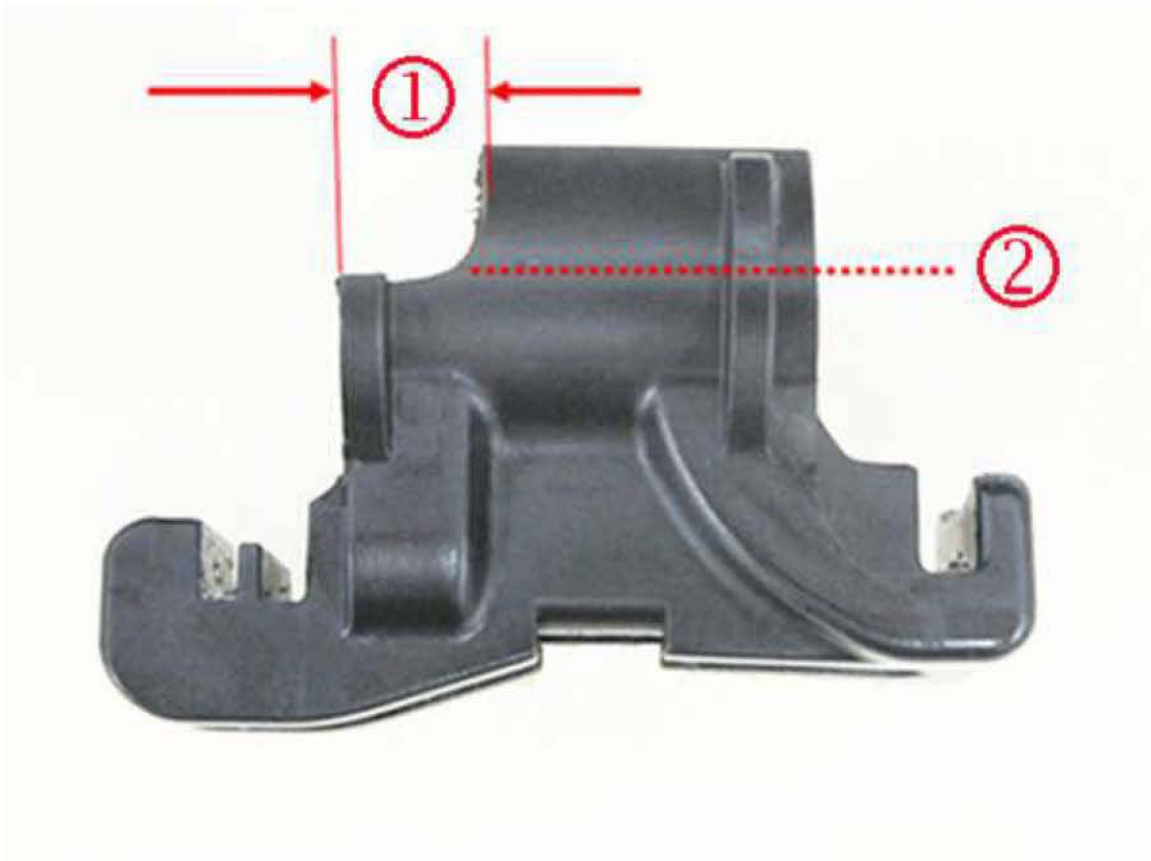

- If brackets are evident, it will be necessary to remove plastic material from the top side of the **guide end** of the clip to enable installation. Using a grinder, or similar tool, remove approximately 10 mm (0.40 in) of material (1) from the top, down to the mold seam line (2).



3. Install the clip as shown. Ensure the clip is fully seated around the crossbar and on the guide block.



Note: You may need to move the crossbar using a flat head screwdriver to properly align the clip.

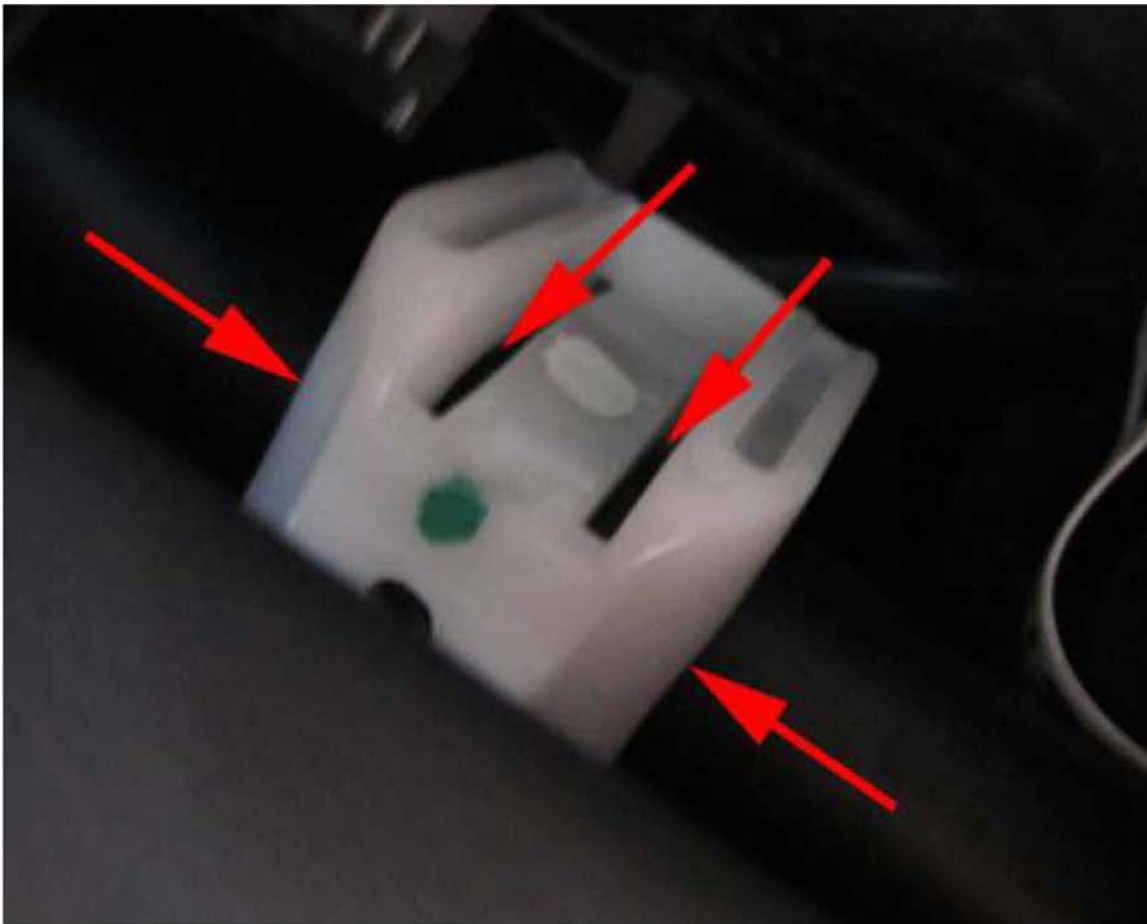

Note: Spray Super Lube, P/N 12346241 (in Canada, P/N 10953474), or equivalent to the areas on the white clip, as shown in the illustration above, to ensure that the noise is eliminated.



4. Install a nylon wire tie as shown. Trim the excess wire tie material.

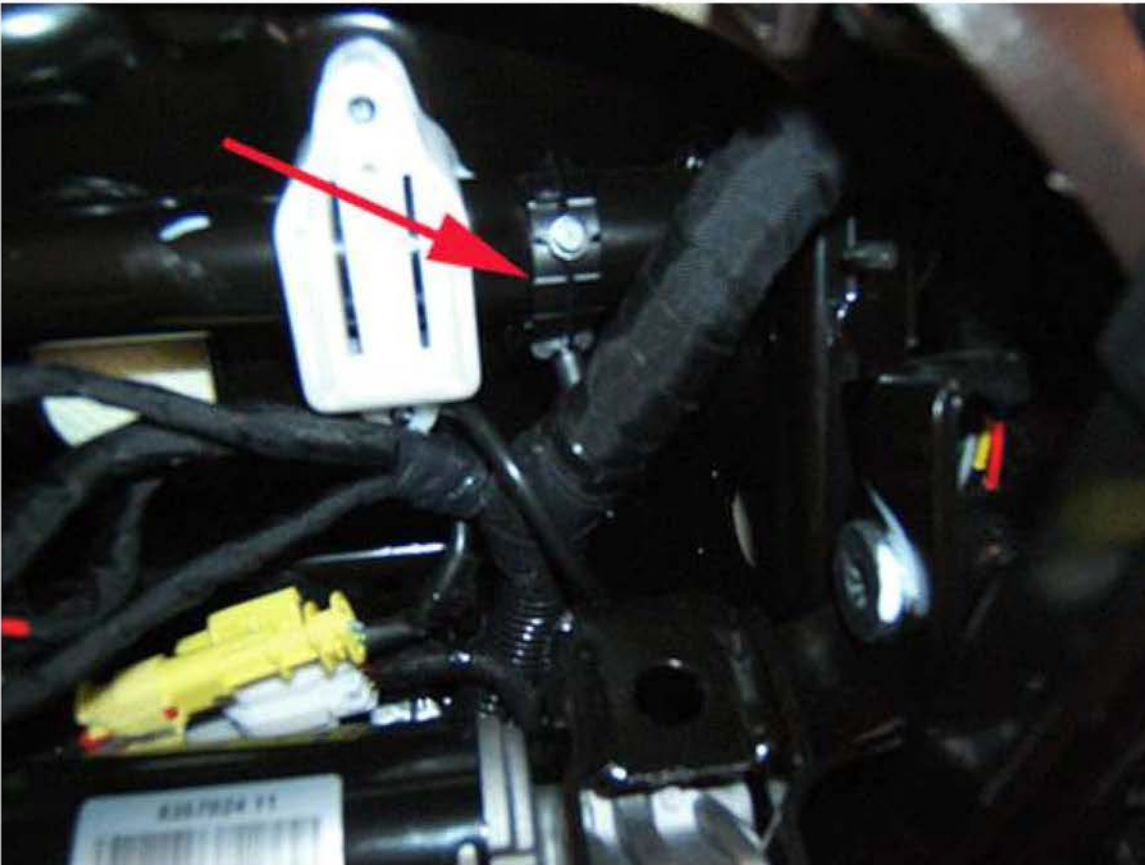

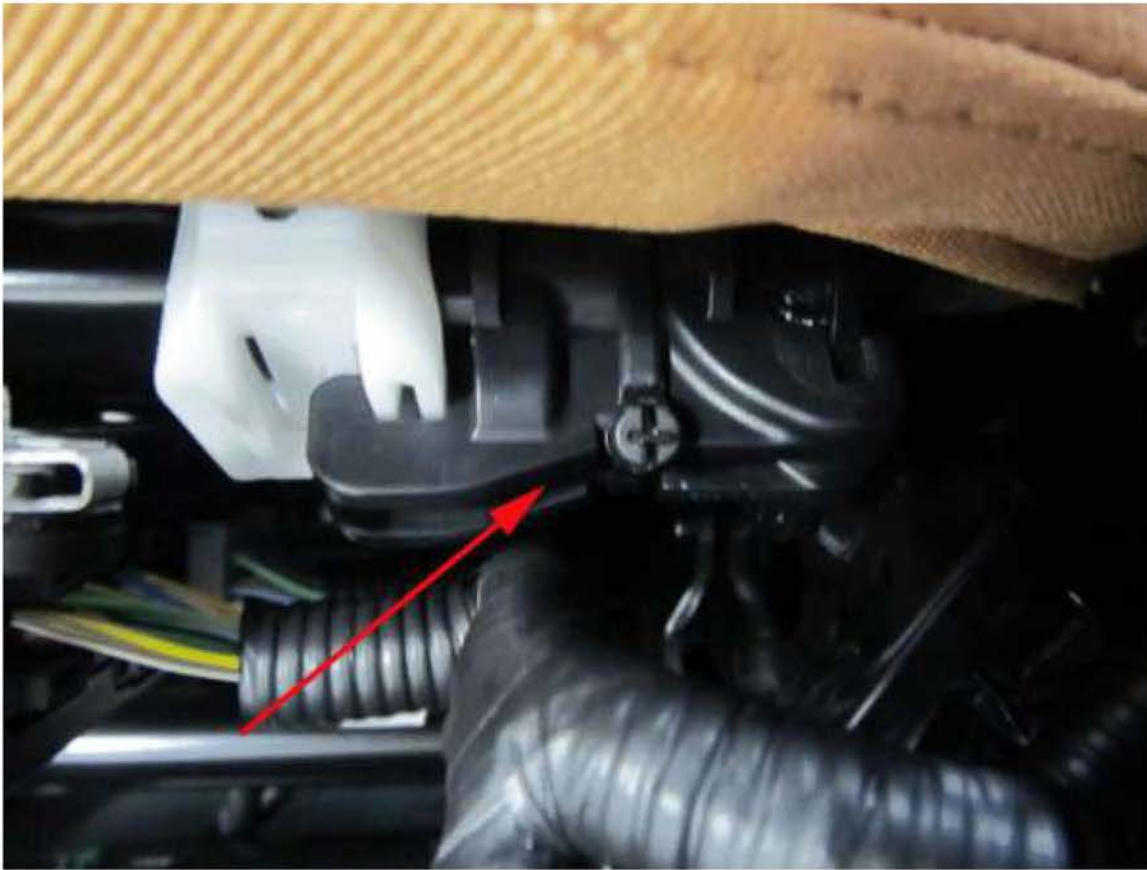

5. On vehicles equipped with power seats, there may be a wire harness attached to the crossbar where the clip is to be installed.
 - If there is a harness clipped to the seat crossbar, remove the harness and clip from the crossbar.
 - Cut the clip off of the harness.
 - Use a second wire tie to re-secure the harness to the new seat clip. Ensure the harness does not come into contact with the connector area of the first wire tie.
 - Ensure that the wire harness is still properly routed after this operation to avoid pinched/cut wires by the power seat mechanism.

Repeat the above steps on the passenger seat if required.

Parts Information

Part Number	Description	Qty
13405675	Front Seat Cushion Lateral Retainer	1 Per Seat

Warranty Information

For vehicles repaired under warranty, use:

Labor Operation	Description	Labor Time
7080068*	Install Front Seat Cushion Lateral Retainer	0.2 hr
Add	For Passenger Seat	0.1 hr

*This is a unique Labor Operation for Bulletin use only.

GM bulletins are intended for use by professional technicians, NOT a "do-it-yourselfer". They are written to inform these technicians of conditions that may occur on some vehicles, or to provide information that could assist in the proper service of a vehicle. Properly trained technicians have the equipment, tools,

safety instructions, and know-how to do a job properly and safely. If a condition is described, DO NOT assume that the bulletin applies to your vehicle, or that your vehicle will have that condition. See your GM dealer for information on whether your vehicle may benefit from the information.



WE SUPPORT VOLUNTARY TECHNICIAN CERTIFICATION